

TM 9-1550-416-14&P

TECHNICAL MANUAL

OPERATOR, UNIT AND INTERMEDIATE
DIRECT AND GENERAL SUPPORT
MAINTENANCE MANUAL
INCLUDING REPAIR PARTS
AND SPECIAL TOOLS LIST

FOR

FQM-117 B-1 AND FQM-117 C-1

NSN-1430-01-313-8342

NSN-1430-01-313-8340

**RADIO CONTROLLED
MINIATURE AERIAL TARGET (RCMAT),
GROUND SUPPORT EQUIPMENT, AND
AUXILIARY EQUIPMENT**

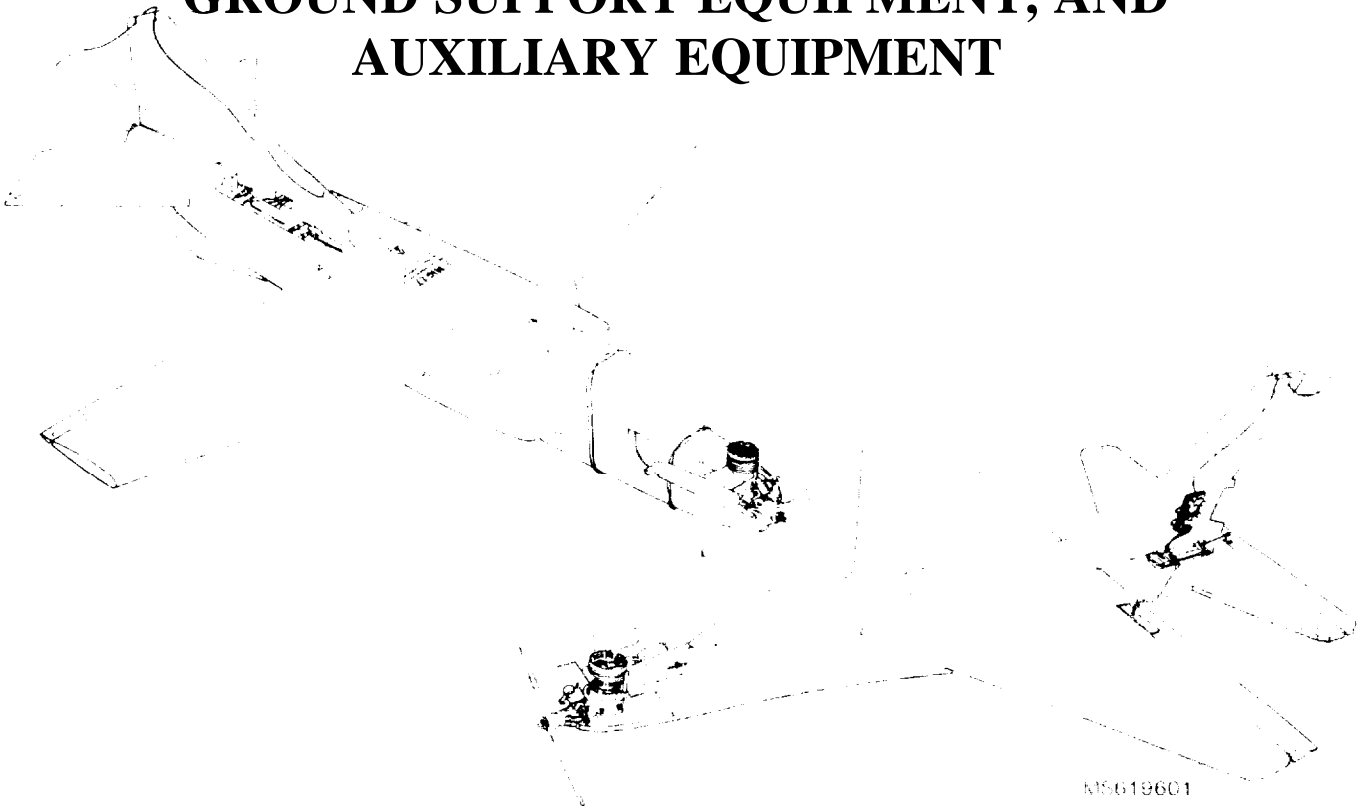

HEADQUARTERS, DEPARTMENT OF THE ARMY

JULY 1990

Change
No. 1

}

**HEADQUARTERS
DEPARTMENT OF THE ARMY**
Washington, D.C., 10 August 1992

**OPERATOR, UNIT AND INTERMEDIATE
DIRECT AND GENERAL SUPPORT
MAINTENANCE MANUAL
INCLUDING REPAIR PARTS
AND SPECIAL TOOLS LIST
FOR
FQM-117 B-1 AND FQM-117 C-1
NSN 1430-01-313-8342 NSN 1430-01-313-8340
RADIO CONTROLLED
MINIATURE AERIAL TARGET (RCMAT),
GROUND SUPPORT EQUIPMENT, AND
AUXILIARY EQUIPMENT**

TM 9-1550-416-14&P, 31 July 1990, is changed as follows:

1. Remove old pages and insert new pages as indicated below. New or changed material is indicated by a vertical bar in the margin of the page. Revised illustrations are indicated by a letter suffix adjacent to the identification number. Added or completely revised sections, paragraphs, tables, etc., are indicated by a vertical line in the title.

Remove Pages

1-3, 1-4
2-17, 2-18
3-3 thru 3-8
3-31 thru 3-33/(3-34
blank)
E-1/(E-2 blank)

Insert Pages

1-3, 1-4
2-17, 2-18
3-3 thru 3-8
3-31 thru 3-33/(3-34
blank)
E-1/(E-2 blank)

2. This transmittal sheet should be filed in the front of the publication for reference purposes.

TM 9-1550-416-14&P

By Order of the Secretary of the Army:

Official:

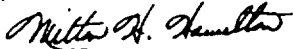

MILTON H. HAMILTON
*Administrative Assistant to the
Secretary of the Army*

02454

GORDON R. SULLIVAN
*General, United States Army
Chief of Staff*

Distribution:

To be distributed in accordance with DA Form 12-32E, Block 0466, Direct Support and General Support Maintenance requirements for TM 9-1550-416-14&P, FQM-117 Miniature Aerial Targets, All Systems.

TECHNICAL MANUAL)
No. 9-1550-416-14&P)

HEADQUARTERS
DEPARTMENT OF THE ARMY
Washington, D.C. 31 July 1990

**OPERATOR, UNIT, AND INTERMEDIATE
 DIRECT AND GENERAL SUPPORT
 MAINTENANCE MANUAL
 INCLUDING REPAIR PARTS AND SPECIAL TOOLS LIST
 FOR
 FQM-117 B-1 AND FQM-117 C-1 RADIO CONTROLLED
 MINIATURE AERIAL TARGET (RCMAT),
 GROUND SUPPORT EQUIPMENT, AND
 AUXILIARY EQUIPMENT**

REPORTING ERRORS AND RECOMMENDING IMPROVEMENTS

You can help improve this manual. If you find any mistakes or if you know of a way to improve the procedures, please let us know. Mail your letter, DA Form 2018, Recommended Changes to Publications and Blank Forms, or DA Form 2028-2 located in the back of this manual directly to Commander, US Army Missile Command, ATTN: AMSMI-LC-ME-P, Redstone Arsenal. Alabama 35898-5238. A reply will be furnished to you.

TABLE OF CONTENTS

		<i>Paragraph</i>	<i>Page</i>
CHAPTER 1	INTRODUCTION		
Section I.	General		
	Scope	1-1	1-1
	Maintenance Forms, Records and Reports	1-2	1-1
	Preparation For Storage and Shipment	1-3	1-1
	Reporting Equipment Improvement Recommendations (EIRs)	1-4	1-1
Section II.	Equipment Description and Data		
	System Characteristics	1-5	1-1
	Locations and Description of Components	1-6	1-1
Section III.	Principles of Operation		
	Aircraft	1-7	1-11
	Receiver and Servo/Battery Group	1-8	1-11
	Transmitter	1-9	1-11
	Support Equipment	1-10	1-11
CHAPTER 2	OPERATING INSTRUCTIONS		
Section I.	Description and Use of Operator's Controls and Indicators		
	Aircraft Controls and Indicators	2-1	2-1
	Receiver and Servo/Battery Group Controls and Indicators	2-2	2-2
	Engine Carburetor Controls and Indicators	2-3	2-3
	Transmitter Controls and Indicators	2-4	2-4
	Ground Support Equipment Field Box Controls and Indicators	2-5	2-6
	Ground Support Equipment Charger Controls and Indicators	2-6	2-7

	<i>Paragraph</i>	<i>Page</i>
Section II.	Preventive Maintenance Checks and Services Procedures	
	Preventive Maintenance Checks and Services Table	2-7 2-8
	Equipment Deficiencies	2-8 2-8
Section III.	Operation Under Usual Conditions	
	General	2-9 2-9
	Initial Adjustments	2-10 2-9
	Adjustment and Alignment Procedures for the Transmitter	2-11 2-14
	Adjustment and Alignment Procedures for Support Equipment	2-12 2-15
	Fueling Procedures for FQM-117 B-1 and FQM-117 C-1	2-13 2-15
	Engine Starting and Adjustments	2-14 2-16
	Control Link Check	2-15 2-18
	Launching Techniques	2-16 2-18
	Flight Control	2-17 2-19
	Flight Profiles	2-18 2-20
	Landing the FQM-117 B-1 and FQM-117 C-1	2-19 2-31
	Standby procedures	2-20 2-31
	Operation of Ground Support Equipment (GSE)	2-21 2-31
	Battery Charging Procedures for Transmitter and Ground Support Equipment (GSE) Field Box Batteries	2-22 2-34
	Battery Charging procedures for Receiver and Servo/Battery Group Batteries.	2-23 2-36
	Utilization Procedures for the GSE Field Box and Transmitter External 12 Vdc Emergency Power Cable	2-24 2-38
CHAPTER 3	OPERATOR MAINTENANCE	
Section I.	Introduction	
	General	3-1 3-1
	Repair Parts	3-2 3-1
Section II.	Service Upon Receipt	
	General	3-3 3-1
	Checking Unpacked Equipment	3-4 3-1
	Unpack GSE Kit	3-5 3-1
	Unpack Aircraft Kit/FQM- 117 B- 1	3-6 3-1
	Unpack Aircraft Kit/FQM-117 C-1	3-7 3-1
	Unpack Transmitter Knit.....	3-8 3-1
	Assembly Procedures for the FQM-117 B-1	3-9 3-2
	Assembly Procedures for the FQM-117 C-1	3-10 3-14
	Transmitter Assembly Procedures	3-11 3-26
	Ground Support Equipment (GSE) Kit Assembly Procedures.	3-12 3-27
Section III.	Troubleshooting Procedures	
	Introduction	3-13 3-28
	General	3-14 3-28
Section IV.	Maintenance procedures	
	Introduction	3-15 3-30
	Preparation for Storage	3-16 3-33
CHAPTER 4	AUXILIARY EQUIPMENT	
Section I.	General	
	Purpose	4-1 4-1
	Location and Description of FSU Components.....	4-2 4-1
	Description and Use for Operator's FSU Controls and Indicators	4-3 4-2

	<i>Paragraph</i>	<i>Page</i>
Section II.	Auxiliary Equipment Assembly and Preparation for Use	
	Unpack Flight Stabilization Kit	4-4 4-3
	Unpack Field Support Kit	4-5 4-3
	Installation of Flight Stabilization Unit.	4-6 4-3
	FSU Installation during Target Assembly.	4-7 4-3
	FSU Installation in an Assembled Target	4-8 4-6
Section III.	Operation of Auxiliary Equipment	4-9 4-6
	Alignment and Adjustment of the FSU	4-10 4-7
	Operation for the FSU	4-11 4-7
	Transmitter Trainer Cord	4-12 4-8
	Transmitter Trainer Cord Assembly Procedures.	
CHAPTER 5	INTERMEDIATE DIRECT SUPPORT MAINTENANCE INSTRUCTIONS	
	Intermediate Direct Support Maintenance.	5-1 5-1
CHAPTER 6	INTERMEDIATE GENERAL SUPPORT MAINTENANCE INSTRUCTIONS	
	Intermediate General Support Maintenance.	6-1 6-1
APPENDIX A	REFERENCES	
Section I.	Introduction	
	General	A-1 A-1
	Publication Indexes	A-2 A-1
	Technical Manuals.	A-3 A-1
	Forms	A-4 A-1
	Other Publications.	A-5 A-1
APPENDIX B	MAINTENANCE ALLOCATION CHART	
Section I.	Introduction	
	General	B-1 B-1
	Maintenance Functions.	B-2 B-1
	Explanation of Format.	B-3 B-1
Section II.	Maintenance Allocation Chart for FQM-117 B-1 and FQM-117 C-1.	B-2
Section III.	Tool and Test Equipment Requirements for FQM-117 B-1 and FQM-117 C-1.	B-7
APPENDIX C	ORGANIZATIONAL, DIRECT SUPPORT, AND GENERAL SUPPORT MAINTENANCE REPAIR PARTS AND SPECIAL TOOLS LIST	
Section I.	Introduction	
	Scope	C-1 C-1
APPENDIX D	COMPONENTS OF END ITEM AND BASIC ITEMS LIST	
Section I.	Introduction	
	Scope	D-1 D-1
	General	D-2 D-1

	<i>Paragraph</i>	<i>Page</i>
Explanation of COEI Columns List	D-3	D-1
Section II. Components of End Item	-	D-1
APPENDIX E EXPENDABLE SUPPLIES AND MATERIALS LIST		
Section I. Introduction..		
Scope	E-1	E-1
Explanation of Columns.....	E-2	E-1
Section II. Expendable Supplies and Materials..	-	E-1
GLOSSARY		
Section I. Abbreviation.....	-	Glossary 1
Section II. Definitions	-	Glossary 1

LIST OF ILLUSTRATIONS

<i>Figure</i>	<i>Title</i>	<i>Page</i>
1-1	FQM-117 B-1, FQM-117 C-1, Transmitter, and Ground Support Equipment (GSE).....	1-2
1-2	FQM-117 B-1 (Mig-27).....	1-5
1-3	FQM-117 C-1 (F-16).....	1-6
1-4	Receiver.....	1-7
1-5	Transmitter.....	1-8
1-6	Ground Support Equipment (GSE) Field Box.....	1-9
1-7	Ground Support Equipment (GSE) Charger.....	1-10
2-1	Mig-27 and F-16 Aircraft.....	2-1
2-2	Receiver and Servo/Battery Group Controls.....	2-2
2-3	Engine Carburetor.....	2-3
2-4	Transmitter Controls and Indicators.....	2-4
2-5	Ground Support Equipment (GSE) Field Box Controls and Indicators.....	2-6
2-6	Ground Support Equipment (GSE) Charger Controls and Indicators.....	2-7
2-7	Control Horn Hole Selection.....	2-9
2-8	Receiver and Servo/Battery Group Connections.....	2-10
2-9	Carburetor Barrel Operation.....	2-11
2-10	Aileron Servo Arm Adjustment.....	2-11
2-11	Aileron Responses To Control Stick and Roll-Trim Control Inputs.....	2-12
2-12	Elevator Responses to Control Stick and Pitch-Trim Control Inputs.....	2-13
2-13	Transmitter Battery Replacement.....	2-14
2-14	FQM-117 B-1 and FQM-117 C-1 Fuel Line Procedures.....	2-15
2-15	Operating the Starter.....	2-16
2-16	Carburetor Adjustment Points.....	2-17
2-17	Launch Procedures for FQM-117 B-1.....	2-19
2-18	RCMAT Range Plan.....	2-20
2-19	Primary Sample Pattern for Small Arms Air Defense.....	2-21
2-20	Alternative Sample Pattern for Small Arms Air Defense.....	2-22
2-21	Strafing Pattern.....	2-23
2-22	Dive Bombing Pattern.....	2-24
2-23	Low-level Penetration Laydown Pattern.....	2-25
2-24	Low-level Penetration Pop-up Pattern.....	2-26
2-25	Attack from the "Loop" Pattern.....	2-27
2-26	Pitch-up Bombing Pattern.....	2-28
2-27	Multiple Aircraft Pattern (Sheet 1 of 2).....	2-29
2-28	Fuel Tank Closure Procedure.....	2-31
2-29	Ground Support Equipment (GSE) Field Box Components and Location.....	2-32
2-30	Ground Support Equipment (GSE) Charger Components and Location.....	2-33
2-31	Voltage Checking of Transmitter.....	2-34
2-32	Voltage Checking of GSE Field Box Battery.....	2-34
2-33	Battery Charging for Transmitter and GSE Batteries.....	2-35
2-34	Voltage Checking of the Receiver and Servo/Battery Group Battery.....	2-36
2-35	Battery Charging for Receiver and Servo/Battery Group Batteries.....	2-37
2-36	External 12 Vdc Emergency Power Cable Operation of the GSE Field Box.....	2-38
2-37	External 12 Vdc Emergency Power Cable Operation of the Transmitter.....	2-39
3-1	Aircraft/FQM-117 B-1 in Exploded View.....	3-2
3-2	Fuel Tank and Canopy Installation.....	3-4
3-3	Horizontal Stabilizer/Elevator Installation.....	3-5

<i>Figure</i>	<i>Title</i>	<i>Page</i>
3-4	Vertical Stabilizer Installation	3-5
3-5	Engine Installation	3-6
3-6	Servo/Battery Group to Receiver Interconnection Diagram	3-7
3-7	Pushrod Installation	3-8
3-8	Antenna Routing	3-9
3-9	Wing Assembly Installation	3-10
3-10	Snap Link Attachment to Throttle	3-10
3-11	Snap Link Attachment to Servo Arms and Aileron Horns	3-11
3-12	Snap Link Attachment to Elevator Horn	3-11
3-13	Ventral Fin Installation	3-12
3-14	Propeller and Muffler Installation	3-12
3-15	Field and Pressure Line Connector	3-13
3-16	Dust Cover Installation	3-13
3-17	Aircraft/FQM-117 C-1 in Exploded View	3-14
3-18	Vertical and Horizontal Fuselage Joining	3-16
3-19	Engine Installation	3-19
3-20	Servo/Battery Module Installation	3-19
3-21	Throttle Pushrod and Sleeve Installation	3-18
3-22	Wing Installation	3-19
3-23	Elevator Joiner Installation	3-20
3-24	Aileron Pushrod Installation	3-21
3-25	Elevator Pushrod Installation	3-21
3-26	Receiver Installation	3-22
3-27	Fuel Tank Installation	3-23
3-28	Antenna Routing	3-24
3-29	Feed and Pressure Line Connection	3-25
3-30	Transmitter Assembly	3-26
4-1	Flight Stabilization Unit (FSU)	4-1
4-2	FSU Controls	4-2
4-3	Hole for FSU Connectors into Receiver Compartment	4-3
4-4	FSU Installation	4-4
4-5	FSU and Receiver and Servo/Battery Interconnection Diagram	4-5
4-6	Instructor/Trainee Cable Hookup	4-8
D-1	Aircraft Kit Contents/FQM-117 B-1	D-8
D-2	Aircraft Kit Contents/FQM-117 C-1	D-9
D-3	Ground Support Equipment (GSE) Kit Contents	D-10
D-4	Transmitter Kit Contents	D-11
D-5	Stabilization Kit Contents	D-12
D-6	Field Support Kit (FSK) Contents	D-13

LIST OF TABLES

<i>Table Number</i>	<i>Title</i>	<i>Page</i>
1-1	Equipment Description and Data	1-3
2-1	Aircraft Controls and Indicators	2-1
2-2	Receiver and Servo/Battery Group Controls and Indicators	2-2
2-3	Engine Carburetor Controls and Indicators..	2-3
2-4	Transmitter Controls and Indicators	2-5
2-5	Ground Support Equipment (GSE) Charger Controls and Indicators..	2-6
2-6	Ground Support Equipment (GSE) Charger Controls and Indicators..	2-7
2-7	Operator Preventive Maintenance Checks and Services..	2-8
3-1	Materials Required for FQM-117 B-1 Assembly..	3-3
3-2	Materials Required for FQM-117 C-1 Assembly..	3-15
3-3	Materials Required for GSE Assembly..	3-27
3-4	Troubleshooting	3-28
3-5	FQM-117 B-1 and FQM-117 C-1 Maintenance Procedures..	3-30
4-1	FSU Controls and Indicators	4-2
4-2	FSU Assembly Components	4-3

SAFETY SUMMARY

The following warnings and cautions appear in the text in this publication and are repeated here for emphasis:

WARNING

- **If propeller contains ANY split ends, cracks, or other damage, replace immediately. (Page 2-8)**
- **The fuel is flammable and burns clear. Use only in well ventilated area. Extinguish all flames and do not light matches or smoke while handling fuel. (Page 2-15 and page 3-32)**
- **When performing engine adjustment, ensure that the glow plug clip is not attached to the glow plug. Injuries could result if engine should start during this step. (Page 2-16)**

CAUTION

- Rotation of the starter is polarity dependent, and the connector can be inserted into the receptacle incorrectly. To preclude the possibility that the engine is rotated in the wrong direction, depress the starter switch and observe that the starter rotation is in a counter clockwise direction when the starter is held in position at the front of the engine prior to attempting to start the engine. If rotation is in a clockwise direction, reverse the starter connector in its receptacle. (Page 2-16)

WARNING

- **Be sure that no personnel other than operators are in the immediate area during operation. The propeller and the area adjacent to each side of the propeller is a danger zone when the engine is running. Keep all personnel away from the propeller. Ensure that clothing, glow plug cable, or starter cable do not become tangled in the propeller. (Page 2-17 and page 2-18)**
- **The last procedure prior to launching the aircraft consists of verifying that the receiver and servo/battery group is turned on and that the control link between the transmitter and aircraft is operating. If the aircraft is launched without control, a crash will result that may endanger personnel. (Page 2-18)**
- **It is extremely hazardous to attempt to launch or fly the aircraft when winds are in excess of 25 knots. (Page 2-18)**
- **Ensure that transmitter antenna is extended to the proper length prior to launch. (Page 2-18)**
- **Never launch or fly the aircraft in the direction of other personnel or toward buildings, structures, or vehicles. (Page 2-18)**

CAUTION

- The landing procedure requires practice. Landing should be performed with minimum damage to the aircraft. Never land the aerial target while the engine is running as the propeller will be broken and airframe damage may result. (Page 2-31)

WARNING

- **During charging procedures, the metal portions of the ground support equipment case will become hot. Avoid contact with the heated surface as burns could result. (Page 2-34 and page 2-36)**

CAUTION

- Constant fast charging tends to deteriorate nicad batteries in a very short time. Do not use fast charging unless it is absolutely necessary. (page 2-34 and page 2-36)
- Be careful to observe proper polarity when connecting the power cable alligator clips to the 12 Vdc power source. (page 2-38 and 2-39)
- When utilizing epoxy to attach components, apply only to mating surfaces. (Page 3-4 and 3-16)
- The servos and the battery, as well as the receiver, are shipped pre-mounted to foam modules. These modules are to be used for installing these components. Do not remove them from these modules. These modules protect the components from damage during flight (Page 3-6)
- The servos and the battery are shipped premounted to a foam mounting plug. This mounting plug is to be used for installing these components. Do not remove them from the mounting plug. It protects the components from damage during flight (Page 3-17)
- Transmitter and receiver must be set to same channel to achieve operation. (page 3-26)

WARNING

- **When performing tests or inspections of engine parts, ensure that glow plug clip is not attached to glow plug. Injuries could result if engine should start during this step. (Page 3-29)**

CAUTION

- Do not force control rods or pushrods to move. Damage to servo gears can result. (Page 3-29)
- Do not turn the propeller if any dirt is visible in the carburetor air intake or exhaust port. Turning the propeller, even slowly, can cause damage and pull dirt into internal parts making cleaning more difficult. (Page 3-31)

WARNING

- **During and immediately after operating, the engine and muffler are hot. Do not touch hot surfaces; it will result in a burn. (Page 3-32)**

WARNING

- **When performing maintenance on engine parts, the glow plug must be cool. Injury could result if the engine should start during this step. (Page 3-32)**

CAUTION

- Do not attempt to start the engine if the shaft is bent or binding. (Page 3-32)
- When cleaning use only clear water. Do not use solvents such as lacquer thinner around plastic or polystyrene parts. (Page 3-33)
- Do not paint any part of the airframe. Paint will damage the polystyrene foam material. (Page 3-33)
- Stabilizers are wrapped in foam packaging. Do not install FSU without foam packaging. (Page 4-4)

CHAPTER 1 INTRODUCTION

Section I. GENERAL

1-1. SCOPE.

a. The information in this manual is published for the guidance of personnel responsible for the operation and maintenance of the FQM-117 B-1 and FQM-117 C-1 radio controlled miniature aerial target (RCMAT), support equipment and auxiliary equipment. (See fig. 1-1.)

b. The FQM-117 B-1 is designed for use in Air Defense small arms training, gunnery practice for VULCAN and M-42 automatic weapons, and tracking training for infrared systems such a CHAPARRAL, REDEYE, and STINGER.

c. The FQM-117 B-1 when combined with the FQM-117 C-1 is designed to be used for Target Identification Training.

d. Unless otherwise specified, the instructions in this manual apply to both FQM-117 B-1 (Mig-27) and the FQM-117 C-1 (F-16). When specific information for each type of aircraft is necessary, it will be noted.

1-2. MAINTENANCE FORMS, RECORDS, AND REPORTS.

a. Department of the Army forms and procedures used for equipment maintenance will be those prescribed by DA PAM 738-750. The Army Maintenance Management System

PAM 738-750. The Army Maintenance Management System (TAMMS). The DA PAM is published in the Maintenance Management UPDATE.

b. Units may subscribe to Maintenance Management UPDATE by submitting a completed DA Form 12-13.

1-3. PREPARATION FOR STORAGE AND SHIPMENT.

Perform the preparation for storage procedures as outlined in paragraph 3-16 before storing the engine for more than 1 week.

1-4. REPORTING EQUIPMENT IMPROVEMENT RECOMMENDATIONS (EIRs).

If your RCMAT needs improvement, let us know. Send us an EIR. You, the user, are the only one who can tell us what you don't like about your equipment. Let us know why you don't like the design or performance. Put it on a SF368 (Quality Deficiency Report.) Mail it to us at the address stated in DA PAM 738-750.

Section II. EQUIPMENT DESCRIPTION AND DATA

1-5. SYSTEM CHARACTERISTICS.

The capabilities, features, and limitations of the RCMAT are furnished in table 1-1.

1-6. LOCATION AND DESCRIPTION OF COMPONENTS.

The location and description of the major aerial target, transmitter, and support equipment components are illustrated in figures 1-2 through 1-7 respectively.

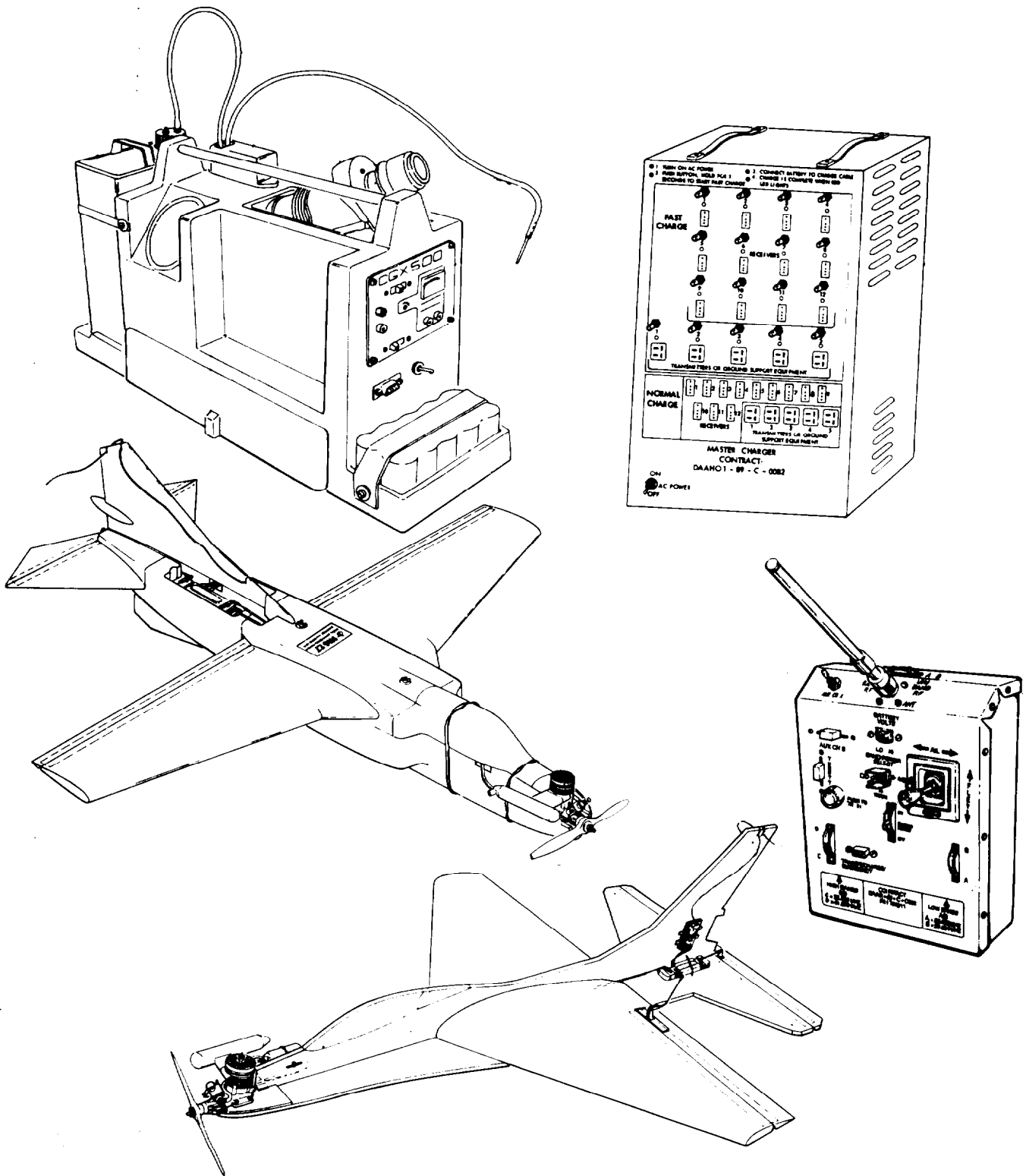

MS819802

Figure 1-1. FQM-117 B-1, FQM-117 C-1 transmitter, and ground support equipment (GSE).

Table 1-1. Equipment Description and Data

Item	Data		
PERFORMANCE			
Speed	Maximum 46 MPH at sea level with zero wind. Minimum 29 MPH at sea level with zero wind.		
Endurance	Minimum of 10 minutes at maximum speed.		
Range	Three kilometers maximum		
Operational Altitudes	Sea level to maximum of 10,000 feet above sea level.		
Maneuverability	Roll rate at full throttle is minimum of 180 degrees per second from level of flight at all operational altitudes. Pitch rate at full throttle is minimum of 60 degrees per second from level flight at all operational altitudes.		
Launch Method	Hand launch in winds up to 25 knots.		
Survivability	Under the conditions of unimproved grassy and/or sandy areas normally found at training and firing ranges, the airborne system is recoverable with a minimum of structural damage. Excluding hits to the engine, fuel, tank, electronics and control mechanisms, the airborne system can survive a small arms hit up to 20 millimeters in size with minimal operational degradation.		
ANCILLARY DEVICES	The airborne system is capable of accommodating a 5 pound, 80-cubic-inch (typical 2.0 inches by 4.0 inches by 10 inches long) payload of uniform density. The payload will not degrade performance characteristics and is carried internally in a payload compartment, or externally. The airborne system will permit a radar signature sufficient for VULCAN ROR (9145 to 9185 MHz) to engage and lock at 500 meters.		
PHYSICAL DIMENSIONS			
Aerial Target	<u>Mig-27</u>		<u>F-16</u>
Wingspan	68.0 inches		44.0 inches
Length	72.0 inches		62.0 inches
Weight	7 pounds 0 ounces		6 pounds 3 ounces
Transmitter	without fuel		without fuel
Width	7.75 inches		
Depth	3.125 inches		
Height	9.25 inches		
Weight	5 pounds 10 ounces		
Antenna			
Transmitter Antenna	Length	Collapsed: 8.5 inches	
		Fully extended: 101 inches	
Receiver Antenna	Length	51.0 inches	
Support Equipment- GSE			
Field Box	Width	22.25 inches	
	Depth	7.25 inches	
	Height	11.5 inches	
	Weight	Approximately 25 pounds with starter and battery installed	

Table 1-1. Equipment Description and Data - Cont.

Item	Data
Charger	Width 12.0 inches Depth 9.875 inches Height 19.0 inches Weight Approximately 45 pounds
ELECTRICAL	
Transmitter	Battery-operated by internal rechargeable, replaceable, 12 volt batteries. Operates on one of four frequencies: 25,450, 25,534, 38,530, or 41,030, selected by external switches.
Receiver	Battery-operated by internal rechargeable 4.8-volt batteries. Operates on one of four frequencies: 25,450, 25,534, 38,530, or 41,030, selected by external switches.
Ground Support Equipment Field Box	Has 12-volt battery that is rechargeable, providing power for the starter, fuel pump, and glow plug.
Charger	115 Vac operated, capable of slow or fast charging of one to twelve receiver and servo/battery group batteries, one to three transmitters and one to two GSE field box batteries 1 1/2 volt AA batteries.
Voltmeter	Battery-operated powered by two standard 1 1/2 volt AA batteries.
ENGINE	
Internal Combustion	Operate after 20 minute break-in. Engine displacement is 0.65 cubic inches minimum.
FUEL SYSTEM	
Capacity	16 ounces
Fuel Mixture	7-10% nitro-methane 18-20% synthetic lubricant 0-2% castor oil 70-73% methanol

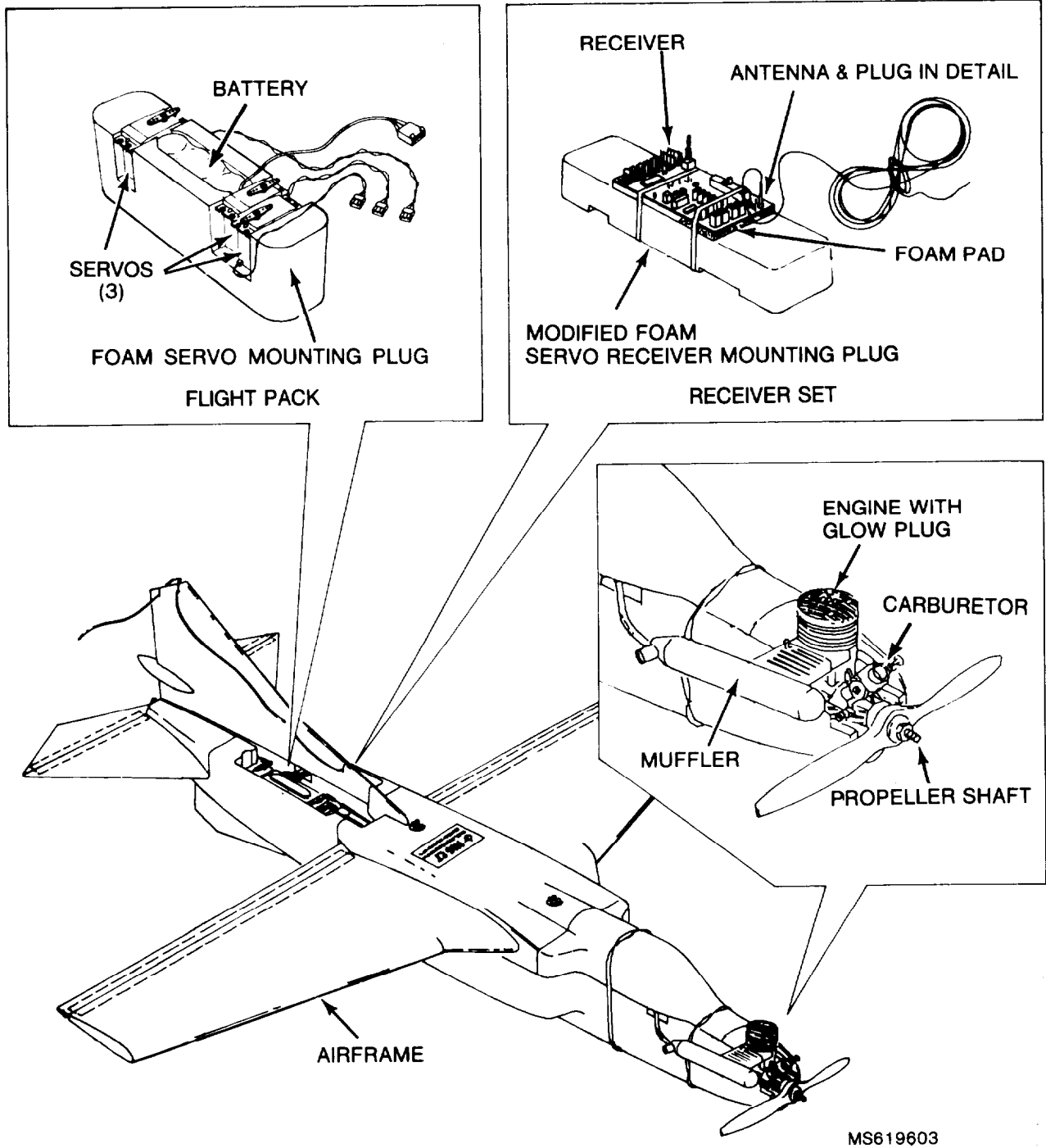
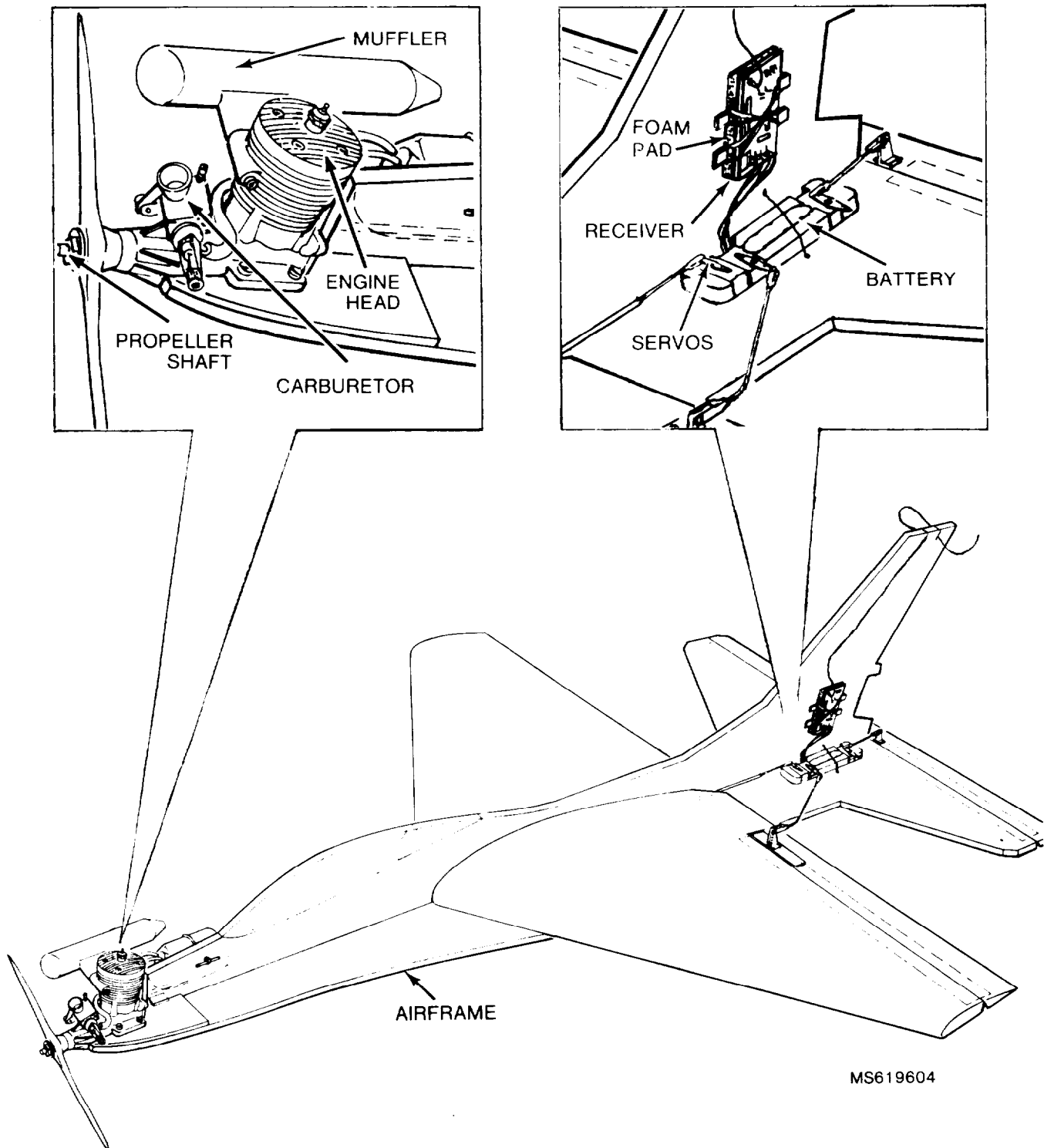

Figure 1-2. FQM-117 B-1 (Mig-27).



MS619604

Figure 1-3. FQM-117 C-1 (F-16).

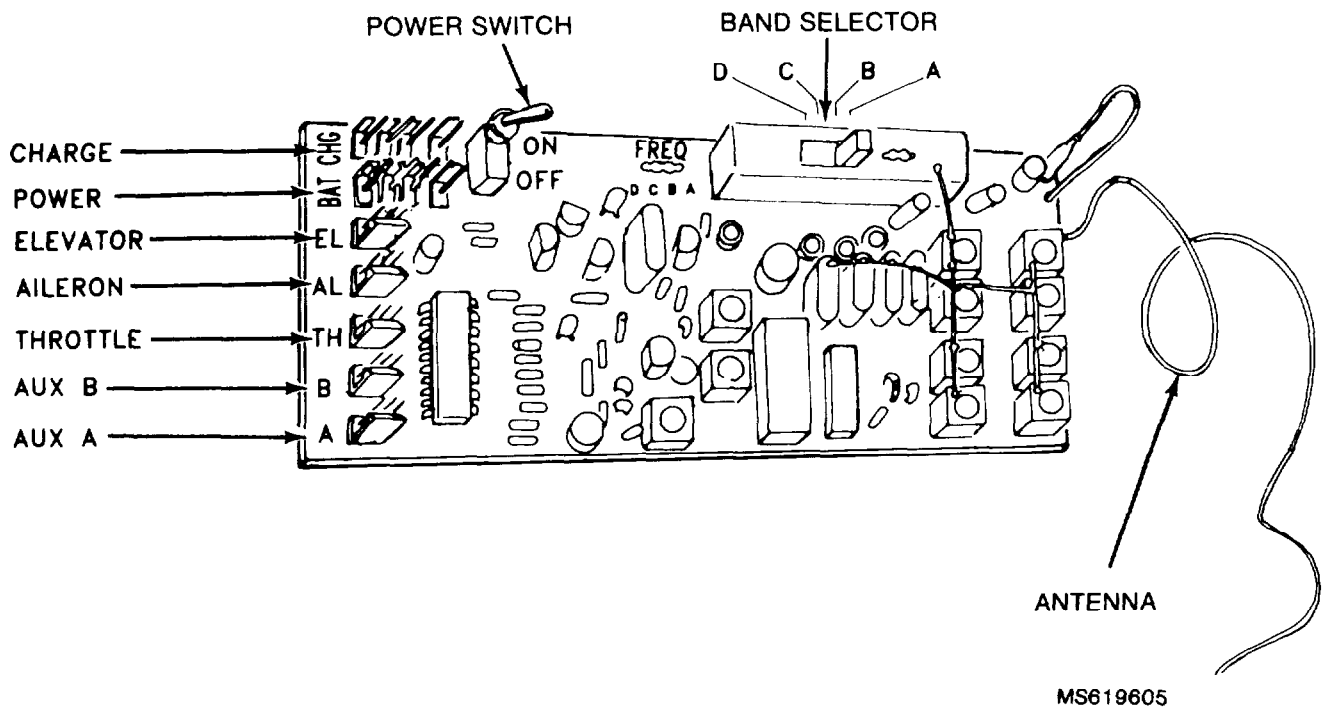
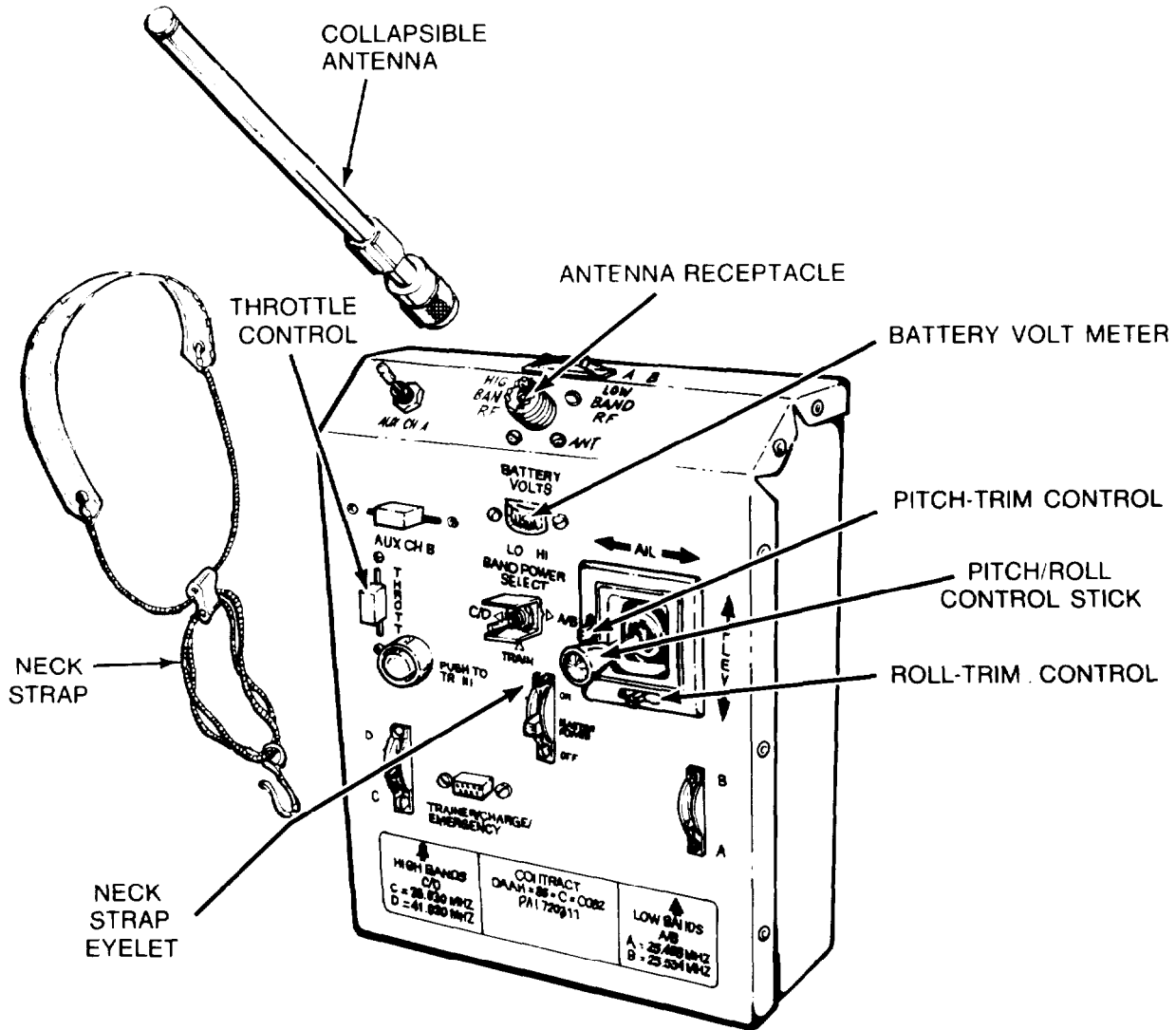

Figure 1-4. Receiver.



MS619606

Figure 1-5. Transmitter.

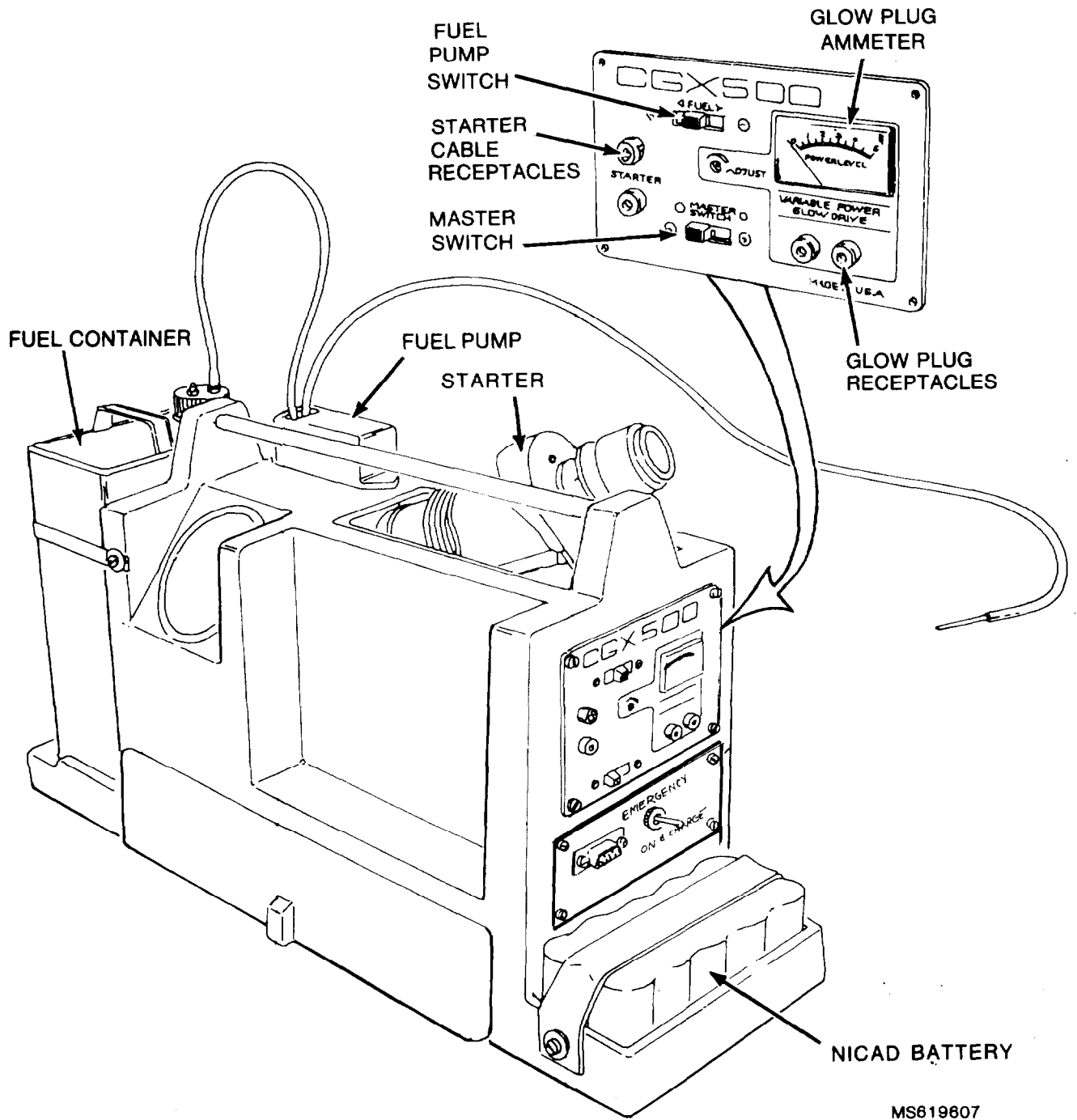

Figure 1-6. Ground support equipment (GSE) field box.

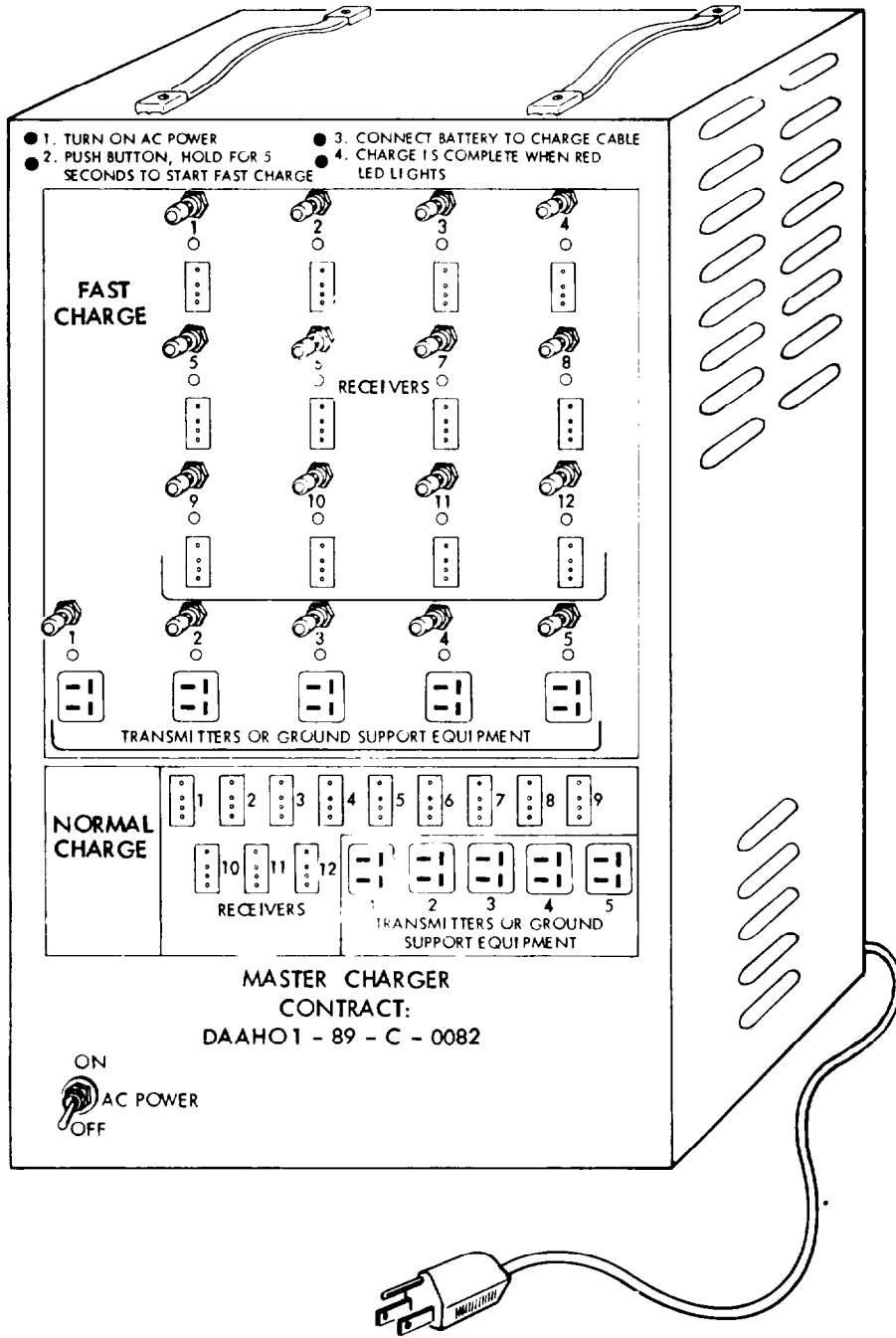

Figure 1-7. Ground support equipment (GSE) charger.

Section III. PRINCIPLES OF OPERATION**1-7. AIRCRAFT.**

The RCMAT consists of an aerial target, or friendly aircraft, that is approximately 1/9 the scale of the aircraft and the electronic control devices (receiver and transmitter) necessary to remotely control the aerial target.

1-8. RECEIVER AND SERVO/ BATTERY GROUP

The receiver along with the servo/battery group is comprised of the receiver with an integral power switch and antenna, servos and battery. It receives and converts the transmitted electronic impulses into mechanical movements which control the aerial target throttle and flight control surfaces.

1-9. TRANSMITTER.

The transmitter contains the throttle and flight controls for the aerial target. Control stick movements (pitch, roll, and throttle) are translated into electrical impulses that are transmitted to the aerial target via an RF link.

1-10. SUPPORT EQUIPMENT.

The support equipment supplies the necessary equipment to properly charge the equipment, fuel the aerial target's fuel tank when necessary, and supply the starting equipment. The support equipment also supplies the necessary storage space for spare parts and tools.

CHAPTER 2
OPERATING INSTRUCTIONS

Section I. DESCRIPTION AND USE OF OPERATOR'S CONTROLS AND INDICATORS.

2-1. AIRCRAFT CONTROLS AND INDICATORS.

The controls and indicators of the aircraft are illustrated in figure 2-1 and explained in table 2-1.

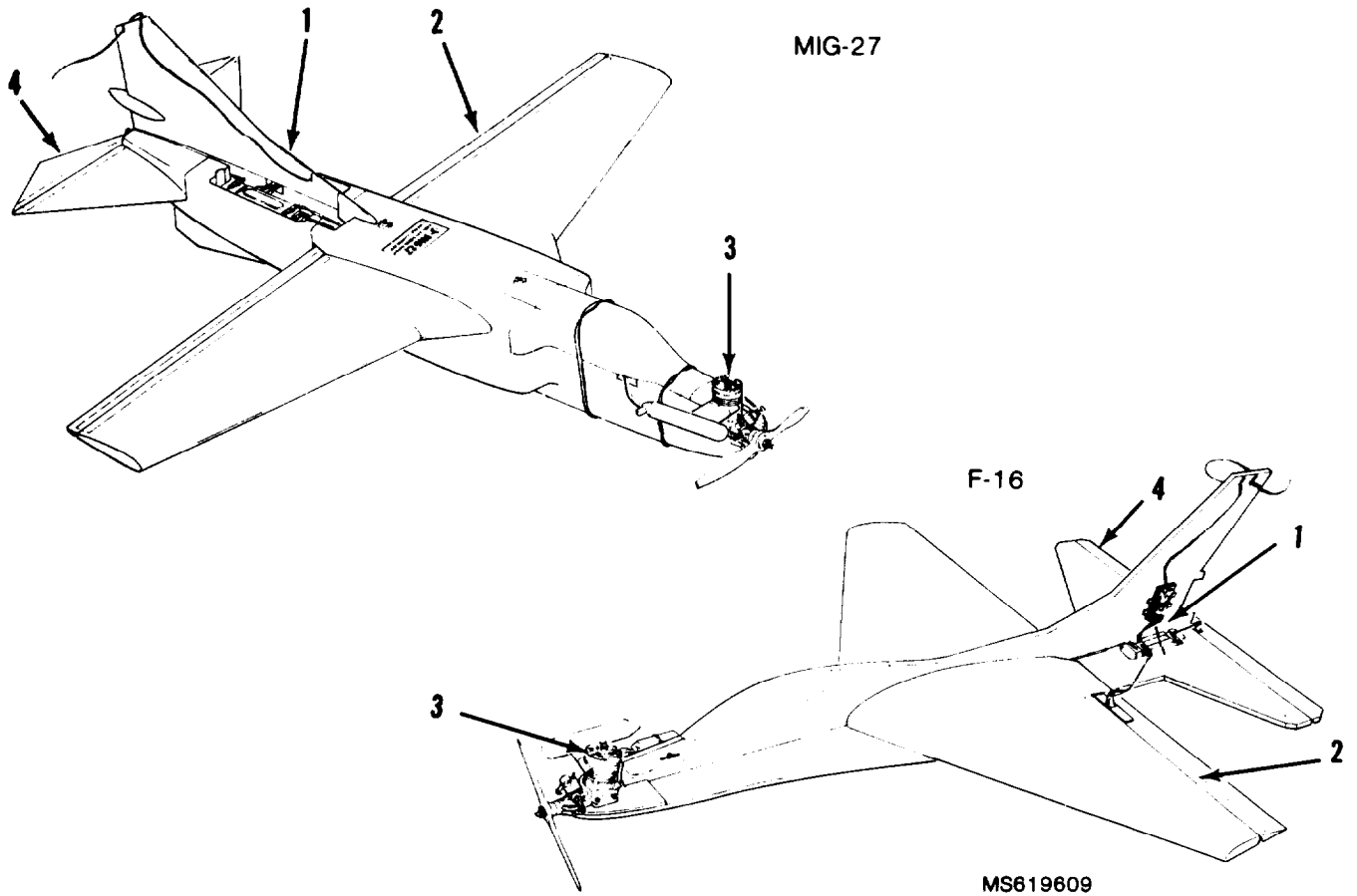

Figure 2-1. Aircraft controls and indicators.

Table 2-1. Aircraft Control and Indicators

<i>Fig. 2-1 Key</i>	<i>Control or Indicator</i>	<i>Function</i>
1	Receiver and servo/battery group	A system used to control the aircraft by a transmitter.
2	Ailerons	Two wing flaps used to control the aircraft's rolling and banking movements.
3	Engine	Converts energy into mechanical motion.
4	Elevator	A movable control surface used to produce up and down motion.

2-2. RECEIVER AND SERVO/BATTERY GROUP CONTROLS AND INDICATORS.

The controls and indicators of the receiver and servo/battery group are illustrated in figure 2-2 and explained in table 2-2.

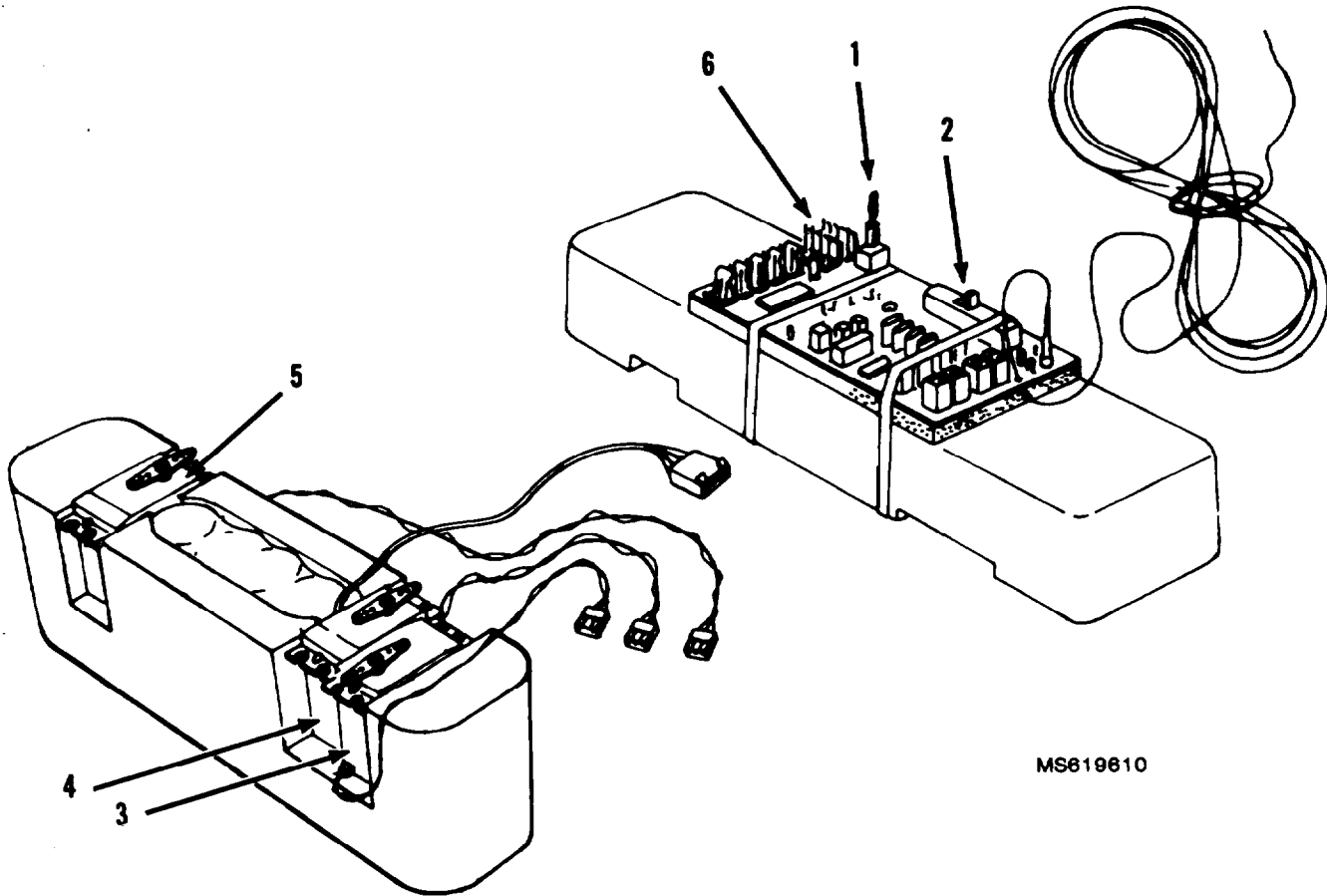

Figure 2-2. Receiver and servo/battery group controls.

Table 2-2. Receiver and Servo/Battery Group Controls and Indicators

Fig. 2-2 Key	Control or Indicator	Function
1	Receiver and servo/battery group power switch	Applies power to the receiver and servo/battery group.
2	Band selector switch	Selects frequency A, B, C, or D beginning at full right-hand position.
3	Aileron servo	Controls movement of the ailerons.
4	Throttle servo	Opens and closes the engine carburetor air-intake valve.
5	Elevator servo	controls movement of the elevator.
6	Receiver and servo/battery group charge connector	Access for battery voltage check and battery charging receptacle.

2-3. ENGINE CARBURETOR CONTROLS AND INDICATORS.

The controls and indicators of the engine carburetor are illustrated in figure 2-3 and explained in table 2-3.

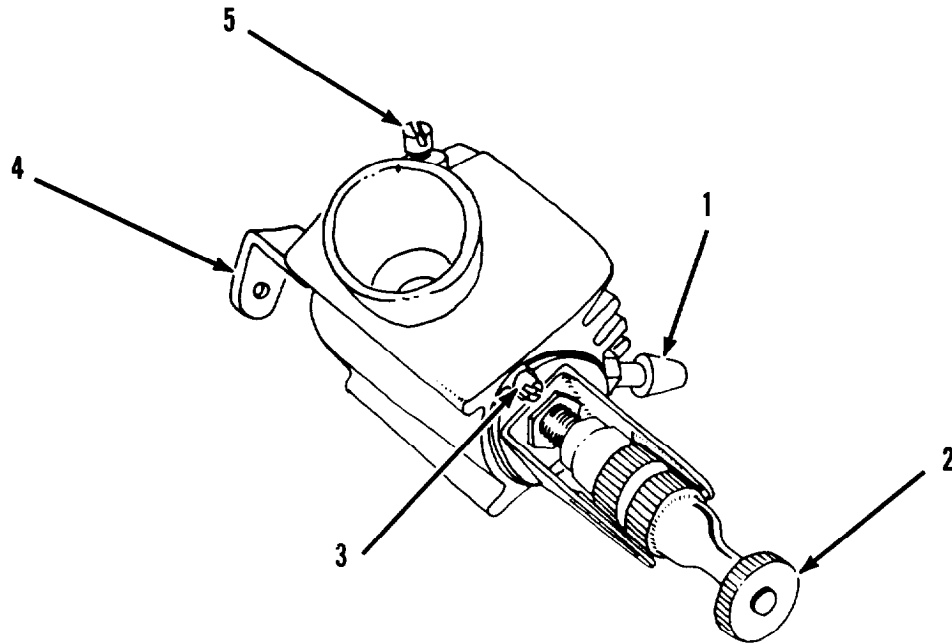

MS619611

Figure 2-3. Engine carburetor.

Table 2-3. Engine Carburetor Controls and Indicators

<i>Fig. 2-3 Key</i>	<i>Control or Indicator</i>	<i>Function</i>
1	Fuel line fitting	Connection for fuel line to bring fuel to carburetor from tank.
2	High speed needle valve	Fine adjustment for fuel mixture at high speed.
3	Idle fuel	Fine adjustment for fuel mixture at idle speed.
4	Throttle arm	Controls Engine RPM.
5	Idle speed screw	Adjustment to increase or decrease the idle speed.

2-4. TRANSMITTER CONTROLS AND INDICATORS.

The controls and indicators of the transmitter are illustrated in figure 2-4 and explained in table 2-4.

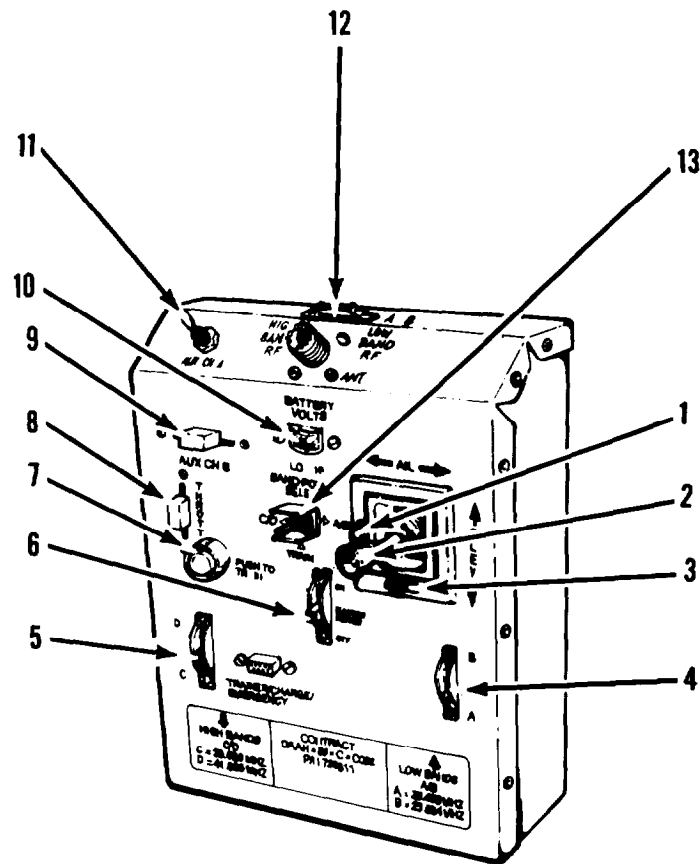

MS619612

Figure 2-4. Transmitter controls and indicators.

Table 2-4. Transmitter Controls and Indicators

<i>Fig.2 -4 Key</i>	<i>Control or Indicator</i>	<i>Function</i>
1	Pitch-trim control	Elevator tine adjustment to keep flight of airplane continuously in a horizontal plane.
2	Pitch-roll control stick	Course adjustment for flight of aircraft. It controls both elevator and ailerons.
3	Roll-trim control	Aileron fine adjustment.
4	Channel A or B switch	Matches A or B channel on receiver.
5	Channel C or D switch	Matches C or D channel on receiver.
6	ON OFF switch	Applies power to the transmitter.
7	Trainer switch	Momentary action pushbutton switch. When depressed, allows trainee to operate the transmitter.
8	Throttle control	Controls the speed of the engine.
9	Auxiliary channel B-auxiliary control	Unused facility.
10	Battery volts meter	Indicates approximate voltage level of battery.
11	Auxiliary channel A-Flight stabilization unit (FSU) switch	ON/OFF toggle switch. When operated engages FSU.
12	RF selector switch	Main RF band radio select switch. Used to set the proper high or low band RF in conjunction with the band selector/trainer switch.
13	Band selector/trainer switch	Main frequency select switch. Used to match frequency A-B or C-D on the receiver or to set transmitter to trainer function.

2-5. GROUND SUPPORT EQUIPMENT FIELD BOX CONTROLS AND INDICATORS.

The controls and indicators of the ground support equipment field box are illustrated in figure 2-5 and explained in table 2-5.

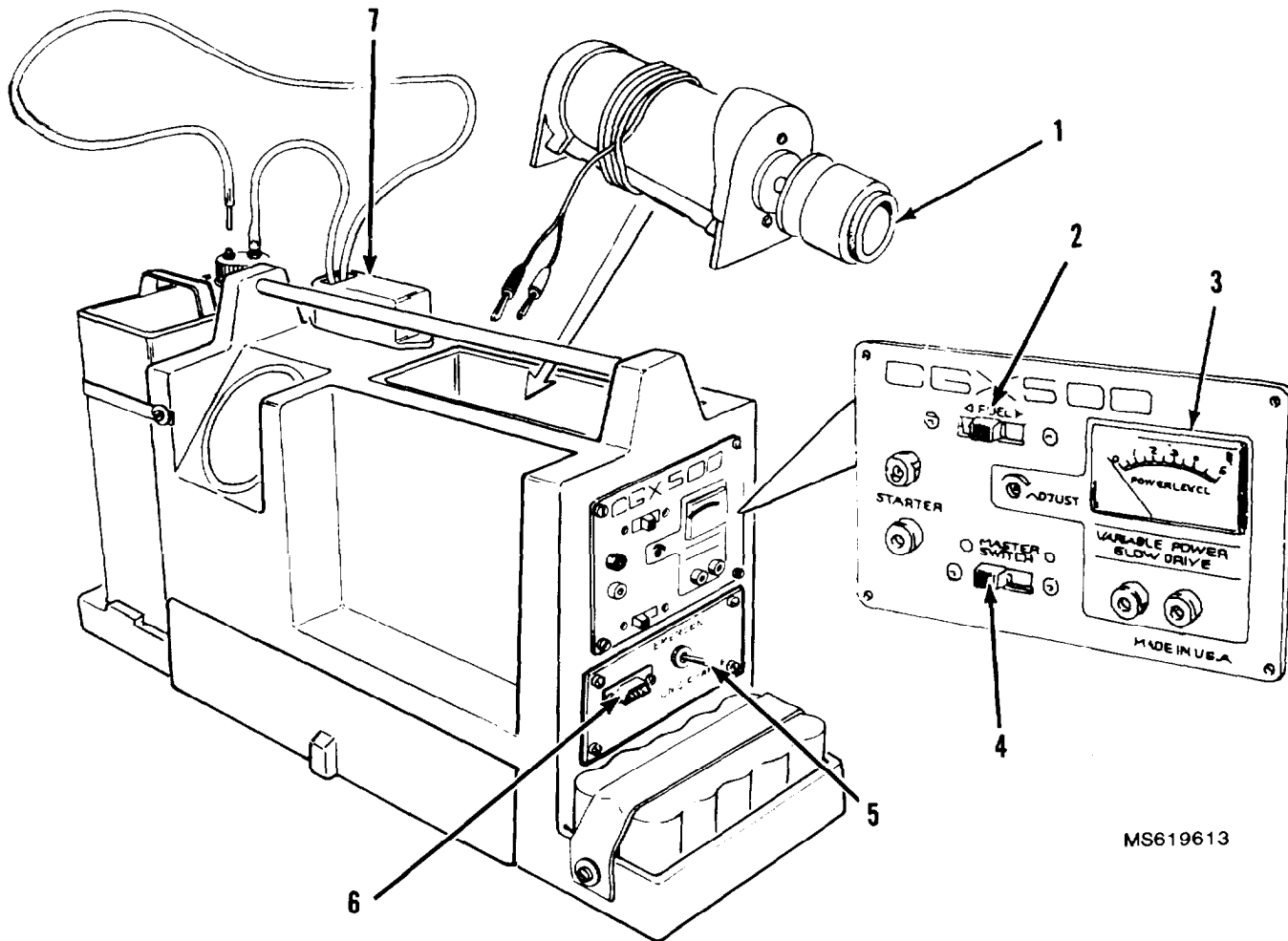

Figure 2-5. Ground support equipment (GSE) field box controls and indicators.

Table 2-5. Ground Support Equipment (SE) Field Box Controls and Indicators

Fig. 2-5 Key	Control or Indicator	Function
1	Starter	Device to start the engine without hand cranking.
2	Fuel pump switch	Center-off-position. The switch is bi-directional and fuel will pump into or out of the fuel tank.
3	Glow plug ammeter	Indicates electric current.
4	Main power panel switch	Applies power to GSE power panel.
5	ON and charge/emergency switch	Allows the GSE field box to be powered by an external 12 Vdc power source.
6	Charger/emergency connector	Plug to charge or run the GSE field box from an external 12 Vdc power source.
7	Fuel pump	Transfers fuel from fuel container to the fuel tank.

2-6. GROUND SUPPORT EQUIPMENT CHARGER CONTROLS AND INDICATORS.

The controls and indicators of the ground support equipment charger box are illustrated in figure 2-6 and explained in table 2-6.

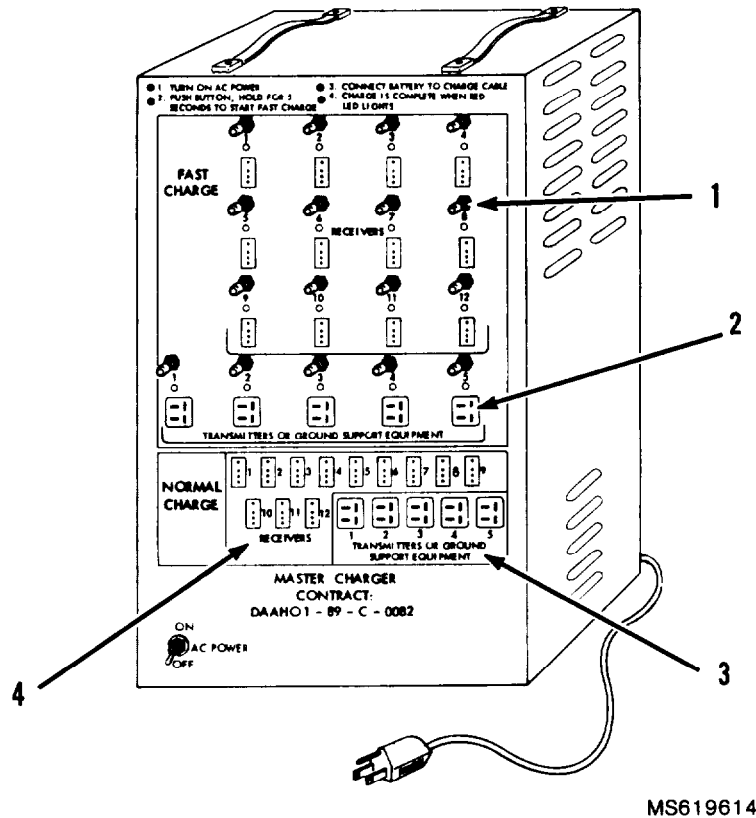

Figure 2-6. Ground support equipment (GSE) charger controls and indicators.

Table 2-6. Ground Support Equipment, (GSE) Charger Controls and Indicators

Fig. 2-6 Key	Control or Indicator	Function
1	Fast charge receptacles, enable buttons and LEDs/receivers	Fast charging of receiver and servo/battery group batteries.
2	Fast charge receptacles, enable buttons and LEDs/transmitters and ground support equipment	Fast charging of transmitters and ground support equipment.
3	Normal charge receptacles/transmitters and ground support equipment	Normal charging of transmitters and ground support equipment..
4	Normal charge receptacles/receiver	Normal charging of receiver and servo/battery group batteries.

Section II. PREVENTIVE MAINTENANCE CHECKS AND SERVICES PROCEDURES

2-7. PREVENTIVE MAINTENANCE CHECKS AND SERVICES TABLE.

a. The Preventive Maintenance Checks and Services (PMCS) table 2-7 lists the inspections and care of the equipment required to keep it in good operating condition.

b. The "Interval" column of the PMCS table tells when to do a certain check or service.

c. The "Procedure" column of the PMCS table tells how to do the required checks and services. Carefully follow these instructions.

2-8. EQUIPMENT DEFICIENCIES.

If your equipment does not perform as required, refer to Chapter 3, Section III, under Troubleshooting for possible problems. Report any deficiencies that cannot be corrected using DA Form 2404 or refer to DAPAM 738-750.

Table 2-7. Operator Preventive Maintenance Check and Services

Item No.	Interval		Item To Be Inspected	Function
	B	A		
1	*	*	Rubber bands	Inspect rubber bands for signs of wear, i.e., tears, fraying, or hardening. Replace if necessary.
2	*	*	Transmitter battery	Check voltage level. Charge the battery if the voltage level is below 12 volts. Use the VOM from the GSE Field Box for voltage level checking on the transmitter charging connector. (See fig. 2-28) Charge if necessary, per paragraph 2-22.
3	*	*	Receiver and servo/battery group battery	Check the voltage level. Charge the battery if the voltage level is below 4.8 volts. Charge if necessary, per paragraph 2-22.
4	*	*	All mounting hardware on aircraft including engine, carburetor and muffler	Check for tightness. Tighten if necessary.
	*	*	GSE battery	Check the voltage level. Charge the battery if the voltage level is below 12 volts. Charge if necessary, per paragraph 2-21.
WARNING				
If propeller contains ANY split ends, cracks, or other damage, replace immediately.				
6	*	*	Propeller	Check for tightness, nicks, cracks, or chips. Replace if necessary.
7	*	*	Airframe assembly	Check for structural damage.

Section III. OPERATION UNDER USUAL CONDITIONS

2-9. GENERAL.

These procedures apply to an RCMAT which has been completely assembled in accordance with instructions in chapter 3, section II.

2-10. INITIAL ADJUSTMENTS.

a Control horn hole selection. Attach clevis to control horn hole 1. (see fig. 2-7.)

NOTE

The control horns on both the elevator and ailerons are manufactured with four positioning holes for snap link attachment.

The selection of which hole to connect is based primarily upon the experience of the aircraft controller. The position of the snap link on the control horn governs the reaction of the aircraft in relation to the amount of movement of the control lever on the transmitter. Positioning the snap link in the hole closest to the control surface causes the control surface to move correspondingly faster and further than it does when the snap link is positioned in the hole farthest from the control surface. This translates into aircraft reaction time during maneuvers. If the aircraft is not responding to control lever inputs during maneuvers to the satisfaction of the controller, the controller can increase or decrease the reaction of the aircraft simply by repositioning the snap link on the control horn.

For minimum movement of the control surface, attach snap link to hole 1.

For intermediate adjustment of control surface, attach snap link to hole 2 or 3.

For maximum movement of the control surface, attach snap link to hole 4.

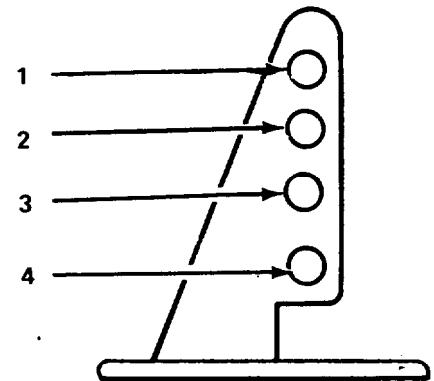

MS619615

- 1 Minimum**
- 2 Intermediate**
- 3 Intermediate**
- 4 Maximum**

Figure 2-7. Control horn hole selection

b. Throttle adjustments.

(1) Observe that throttle servo arm is in fully forward position. (See fig. 2-8.) To adjust, remove servo arm screw and servo arm. Reposition servo arm and replace servo arm screw.

(2) Operate transmitter throttle control from full up to down and observe that the throttle servo responds correctly. Return throttle control to full up.

(3) Adjust throttle pushrod length to ensure that the carburetor is fully opened when the snap link is attached to the throttle servo arm. (See fig. 2-8.)

MIG-27

F-16

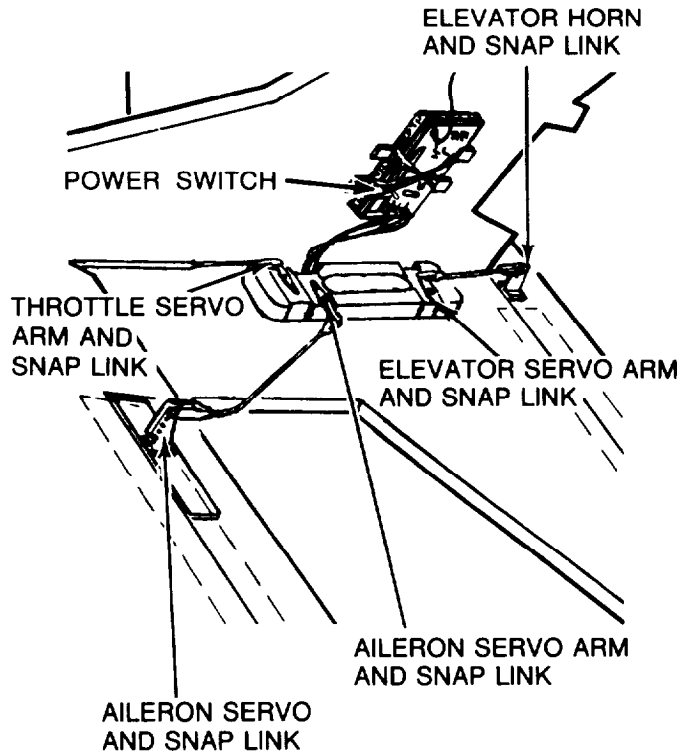
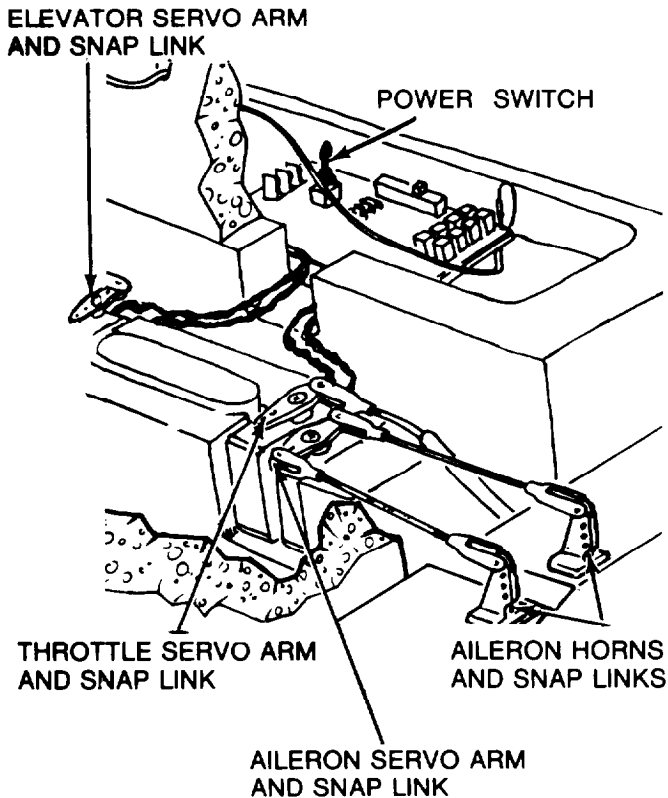

MS649616

Figure 2-8. Receiver and servo/battery group connections.

(4) Operate transmitter throttle control several times and observe throttle pushrod for proper operation.

(5) Operate transmitter throttle control from full up to full down and observe that throttle servo and carburetor barrel move from fully opened to fully closed position. (See fig. 2-9.)

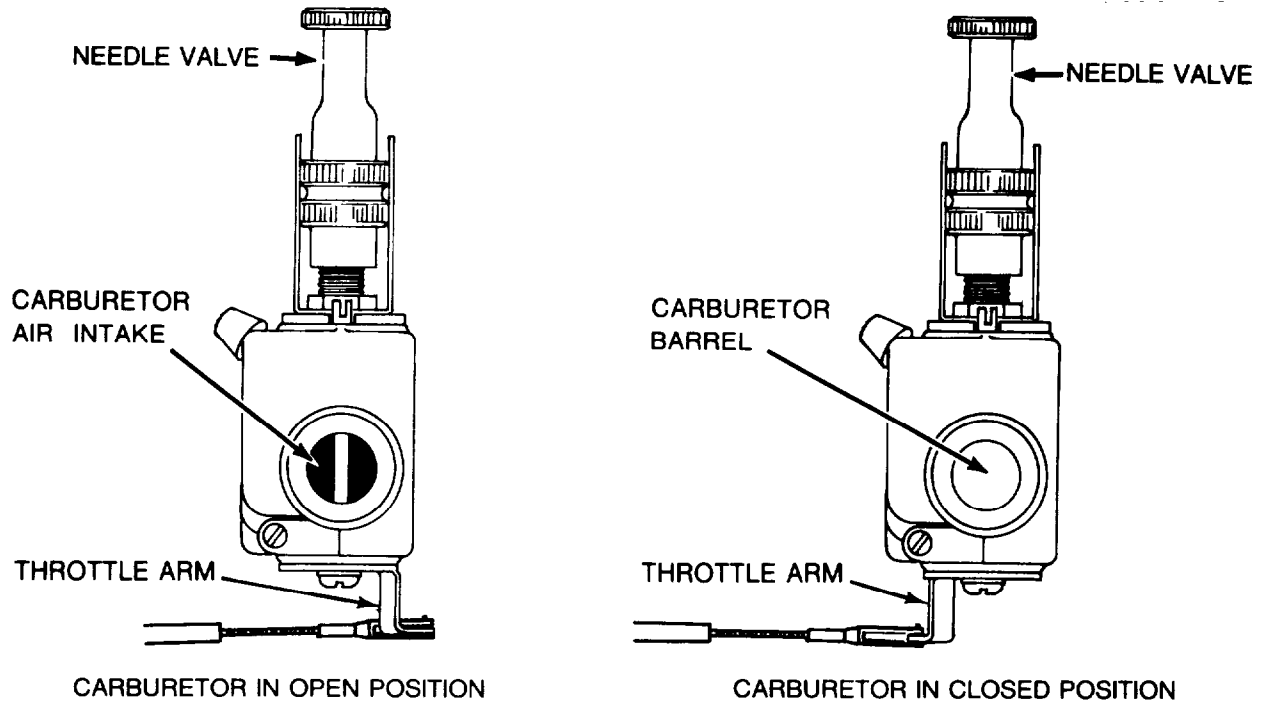

MS619617

Figure 2-9. Carburetor barrel operation.

c. Aileron adjustments.

- (1) Observe that the aileron servo arm is aligned

To adjust, remove servo arm screw and servo arm. Reposition servo arm and replace servo arm screw.

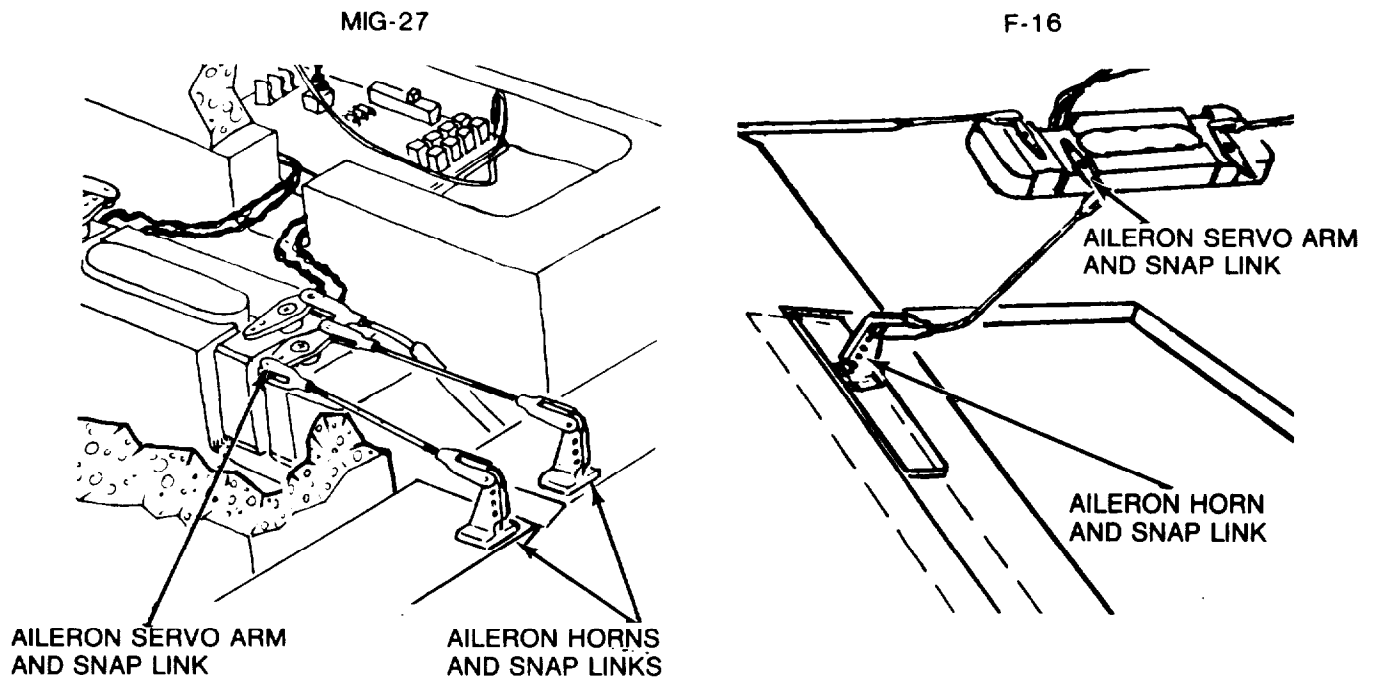

MS619618

Figure 2-10. Aileron servo arm adjustment.

(2) Operate transmitter roll-trim control from fully left to fully right position and observe that the ailerons respond correctly. Return roll-trim control to mid-range. (See fig. 2-11.)

(3) Operate transmitter control stick from spring-loaded center position to fully left and fully right position and observe that ailerons respond correctly. (See fig. 2-11.)

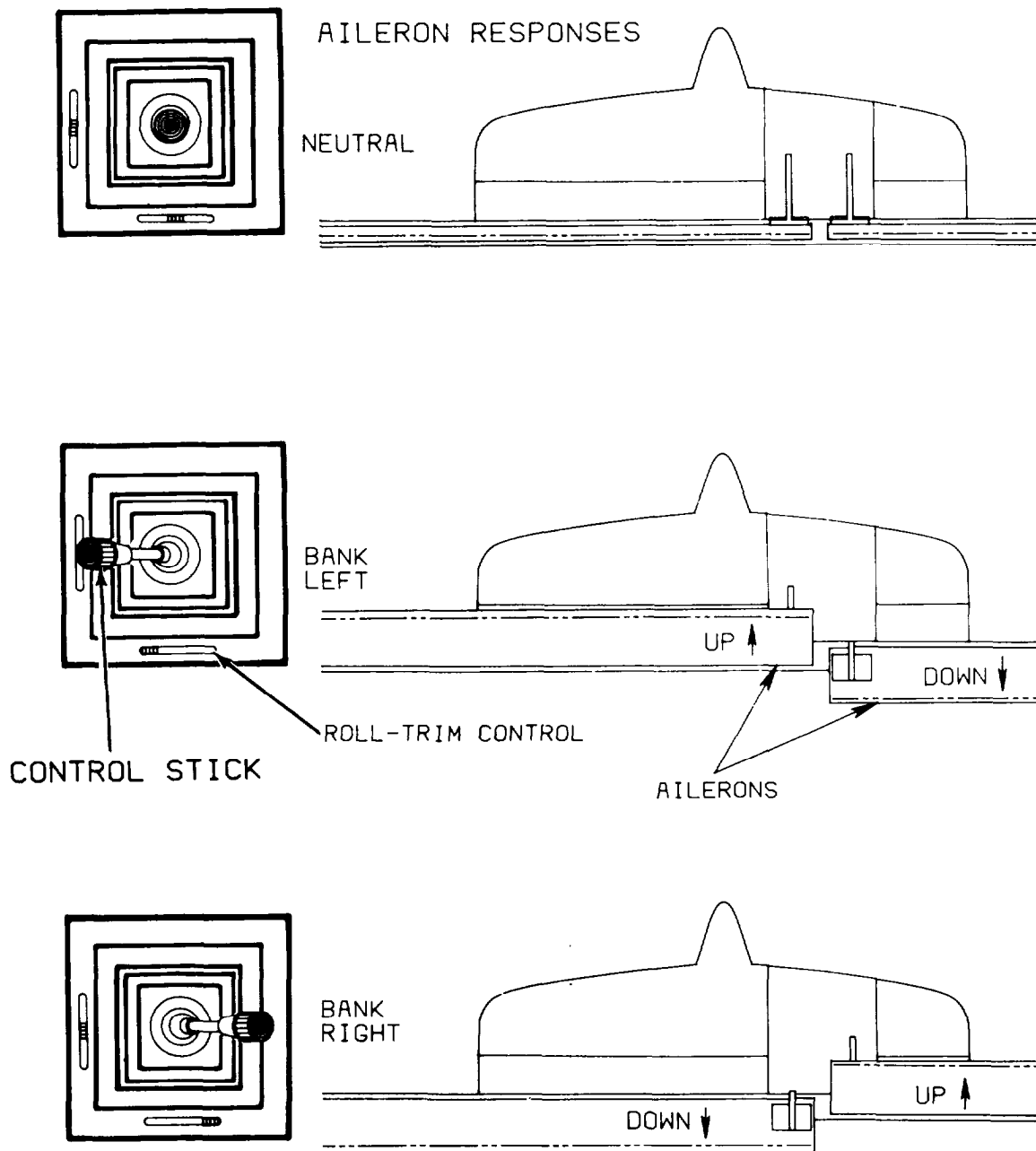

MS619619

Figure 2-11. Aileron responses to control stick and roll-trim control inputs.

d. Elevator adjustments.

(1) Observe that the elevator servo arm is aligned parallel with trailing edge of wing assembly. (See fig. 2-8.) To adjust, remove servo arm screw and servo arm. Reposition servo arm and replace servo arm screw.

(2) Adjust pushrod length to allow full travel of the pushrod to respond to commands.

(3) Operate transmitter pitch-trim control from full down to full up and observe that elevator responds correctly. Return control to midrange position. (See fig. 2-12.)

(4) Operate transmitter control stick from spring-loaded center position to full down and full up and back to center and observe that elevator responds correctly. (See fig. 2-12.)

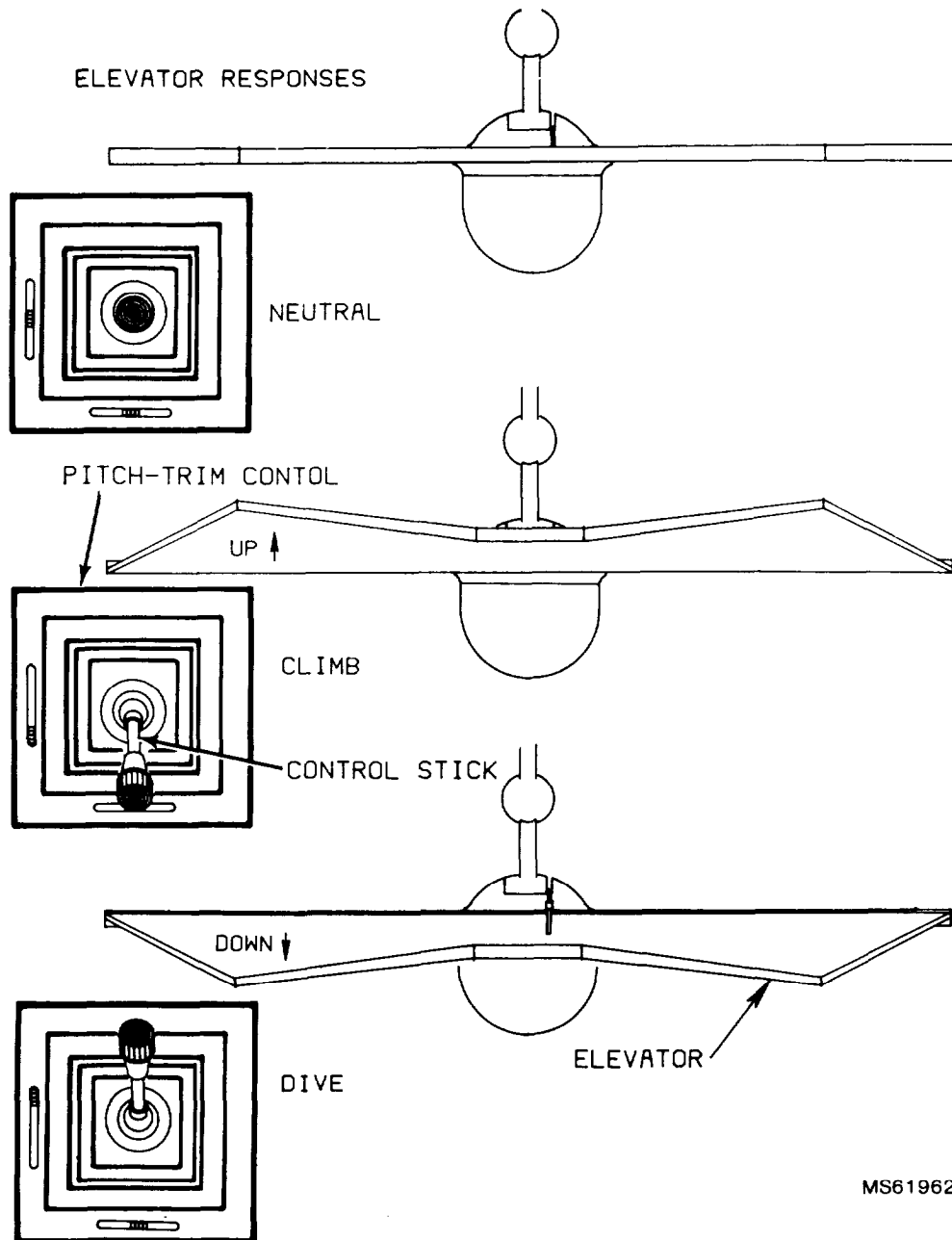

MS619620

Figure 2-12. Elevator responses to control stick and pitch-trim control inputs.

2-11. ADJUSTMENT AND ALIGNMENT PROCEDURES FOR THE TRANSMITTER.

a. *Antenna Length Selection.* Under normal range flying conditions the antenna on the transmitter need only be extended approximately half its total length. Normal range flying conditions is defined as when the RCMAT does not fly more than one kilometer from the transmitter in any one direction.

NOTE

If interference is present it may be necessary to extend the antenna to full length to ensure safe operation.

When flying at extended ranges beyond one kilometer, the transmitter antenna must always be fully extended.

b. *Battery Replacement.* (See fig. 2-13.) The battery in the transmitter is field replaceable. Remove the four screws in the lower panel and set the screws and panel aside. Take out the dunnage and the battery while carefully unplugging the connector from the board. Install the replacement battery after carefully plugging the battery connector into the board. Ensure that the black lead on the battery connector is to the outside of the board. Put the dunnage back in and reinstall the lower panel with the four screws.

c. Transmitters must be returned to the manufacturer for internal adjustment, alignment or repair.

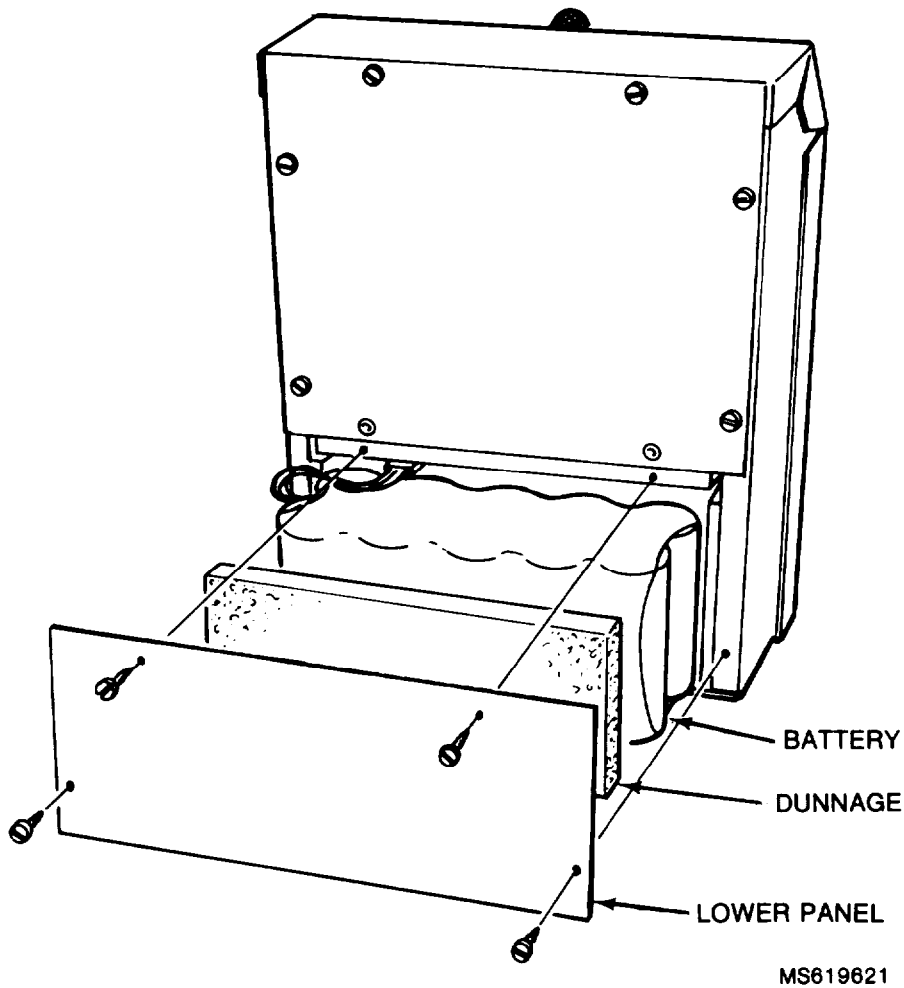

Figure 2-13. Transmitter battery replacement.

2-12. ADJUSTMENT AND ALIGNMENT PROCEDURES FOR SUPPORT EQUIPMENT.

There are no adjustment or alignment procedures required on the support equipment.

2-13. FUELING PROCEDURES FOR FQM-117 B-1 AND FQM-117 C-1.

WARNING

The fuel is flammable and burns clear. Use only in well ventilated area. Extinguish all flames and do not light matches or smoke while handling fuel.

- a. The equipment required to perform the fueling procedures are contained in the support equipment.
- b. Procedures for fueling the aerial target are contained in this paragraph. The setup is shown in figure 2-14. Perform the following fueling procedures.

- (1) Disconnect the fuel tubing from the carburetor.

- (2) Remove fueling probe from fitting on the fuel container cap and connect it to the carburetor feed line.
- (3) Disconnect pressure line from muffler pressure fitting.
- (4) Set main power panel switch to ON.

NOTE

Fuel pump power panel switch is bidirectional and fuel will pump into or out of the fuel tank.

- (5) Operate power panel fuel pump switch in the direction necessary to pump fuel into the fuel tank.
- (6) Continue pumping the fuel until fuel is observed coming from the pressure line.
- (7) On the power panel, position the controls as follows:
 - (a) Set fuel pump switch to OFF.
 - (b) Set power panel switch to OFF.
- (8) Reconnect pressure line to muffler pressure fitting.
- (9) Disconnect fueling probe from carburetor line.
- (10) Reconnect tubing from fuel tank to carburetor.

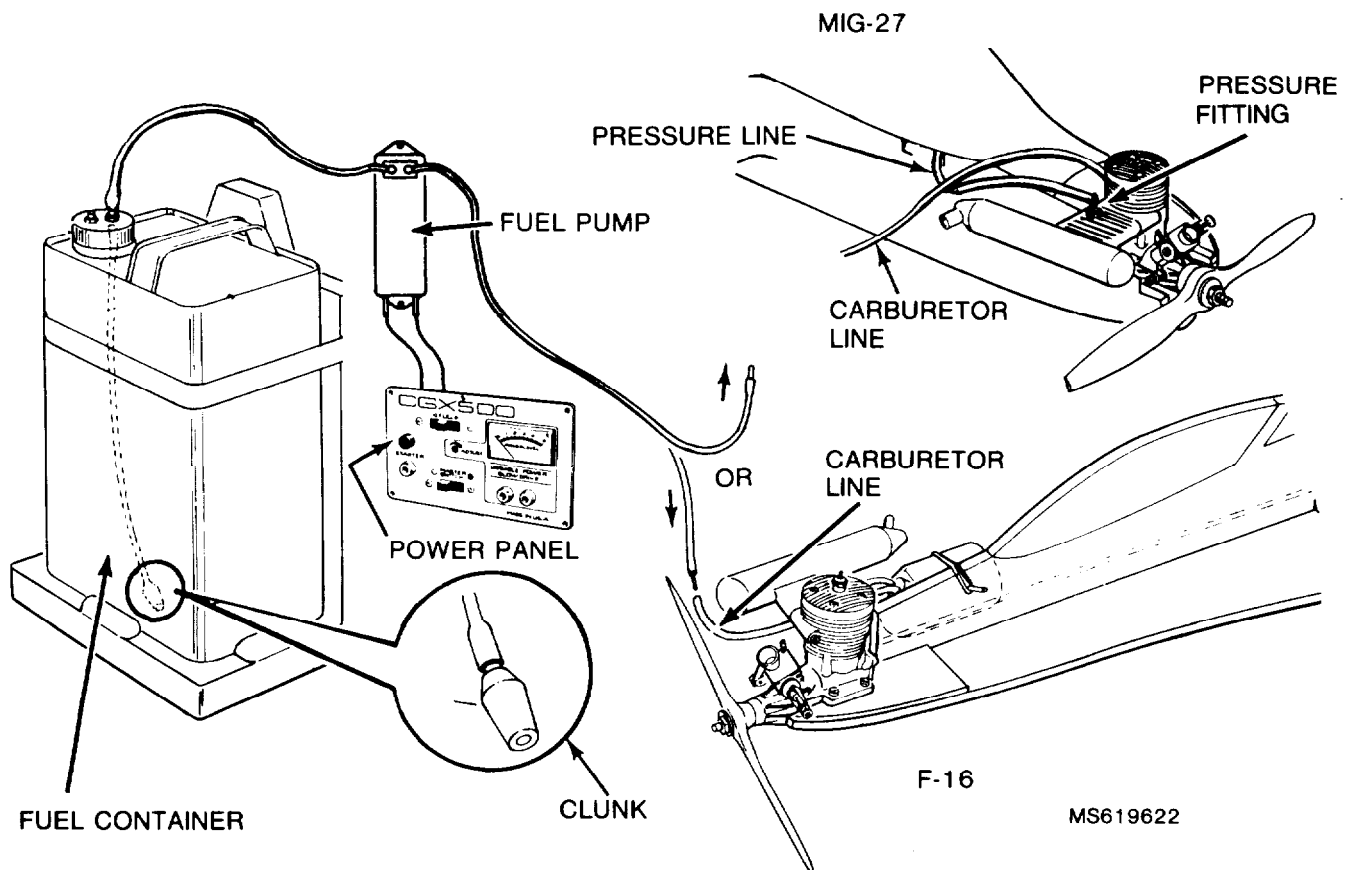

Figure 2-14. FQM-117 B-1 and FQM-117 C-1 fueling procedures.

2-14. ENGINE STARTING AND ADJUSTMENTS.

- a. On the transmitter, position the controls as follows:
- | | |
|----------------------|-------------------|
| POWER SWITCH | ON |
| THROTTLE | MAXIMUM (full up) |
| PITCH-TRIM | MID-RANGE |
| ROLL-TRIM | MID RANGE |
| BAND SELECTOR SWITCH | AS REQUIRED |
| CHANNEL SWITCH | AS REQUIRED |
| RF SWITCH | AS REQUIRED |

b. On the receiver and servo/battery group, set the ON-OFF switch to ON and the frequency switch as required.

c. On the transmitter, operate the throttle control from maximum to minimum. Observe the carburetor barrel through the air intake opening. The barrel should move from fully opened to fully closed as the throttle control is operated. Turn the idle speed screw so that the barrel is fully closed when the throttle control is at the lower limit.

WARNING

When performing step d, ensure that the glow plug clip is not attached to the glow plug. Injuries could result if engine should start during this step.

d. Set the transmitter throttle control to maximum. Place thumb over the carburetor air intake and turn the propellor by hand four complete cycles counter clockwise to prime (choke) the engine in preparation for starting. Do not attach glow plug clip to the engine during this procedure.

e. Check that the glow plug cable is connected to the GLOW PLUG connectors on the power panel. Now attach the glow plug clip to the engine glow plug. (See fig. 2-15.)

f. Connect engine starter to STARTER connector on the main power panel.

CAUTION

Rotation of the starter is polarity dependent, and the connectors can be inserted into the receptacles incorrectly. To preclude the possibility that the engine is rotated in the wrong direction, depress the starter switch and observe that the starter rotation is in a counter clockwise direction when the starter is held in position at the front of the engine prior to attempting to start the engine. If rotation is in a clockwise direction, reverse the starter connectors in its receptacles.

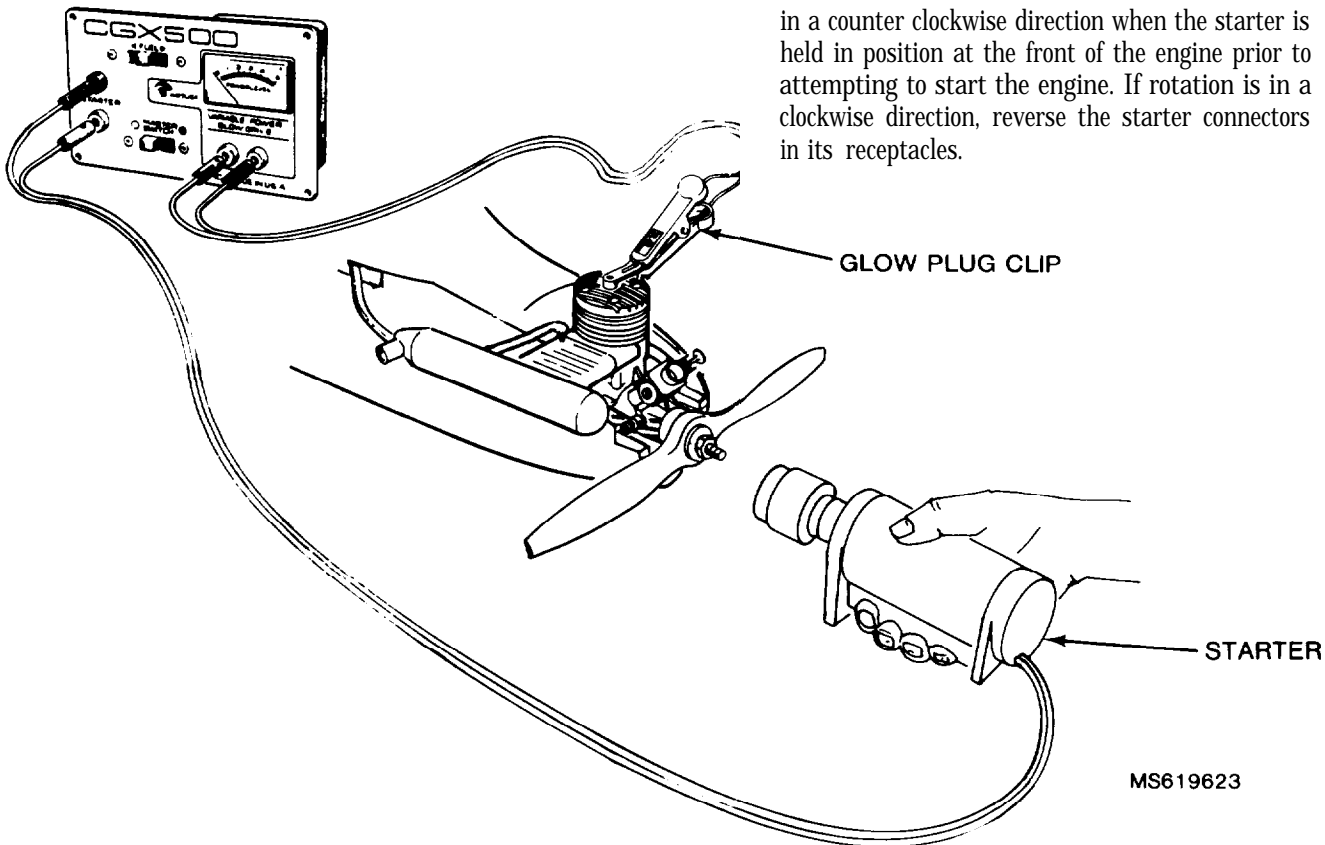

Figure 2-15. Operating the starter.

g. Turn power panel ON.

WARNING

Be sure that no personnel other than operators are in the immediate area during operation. The propeller and the area adjacent to each side of the propeller is a danger zone when the engine is running. Keep all personnel away from the propeller. Ensure that clothing, glow plug, neck strap, cable, or starter cable do not become tangled in the propeller.

h. Close the needle valve clockwise completely and then open counter clockwise two or three turns. (This step is only to be performed the first time the engine is started.)

i. Have two personnel, the controller and assistant, start the engine. The assistant holds the aircraft in place. The controller holds the nose with one hand and places the engine starter over the propeller nut against the propeller and squeezes the starter trigger.

j. The engine should start within three seconds. If not, release engine starter, allow 10 seconds for glow plug to reheat, and repeat starting procedures. (If engine fails to start, refer to table 3-4, troubleshooting procedures.) If engine starts, but fails to run properly, continue steps as outlined. If engine appears to run properly, disconnect glow plug and proceed to step m.

k. With engine running, disconnect glow plug clip. If engine stalls, replace glow plug clip. If engine still stalls when clip is removed, carburetor is set too rich. Adjust carburetor to proper setting.

l. Adjust the needle valve for high speed (indicated by transition from 4-cycle burbling sound to 2-cycle screaming sound). Carburetor barrel must be fully opened for this adjustment. (For carburetor adjustment procedures, see figure 2-16.)

m. Operate the throttle control on transmitter to bring engine to idle. Listen carefully for a few seconds. If engine gradually speeds up and dies, idle mixture is too lean. Adjust idle mixture a very small amount. If the engine runs slower and slower and then quits, idle mixture is too rich.

n. After each idle mixture adjustment, restart the engine is necessary. Return to full throttle, then idle, and check the adjustment.

o. A final test is to hold the nose of the plane up at 45 degrees and then down at 45 degrees. Indications are as follows:

UP	ADJUSTMENT
Engine quits	Too lean
Engine does not speed up	Too lean
Engine speeds up	Okay

DOWN	ADJUSTMENT
Engine quits	Too rich
Four cycles	Okay

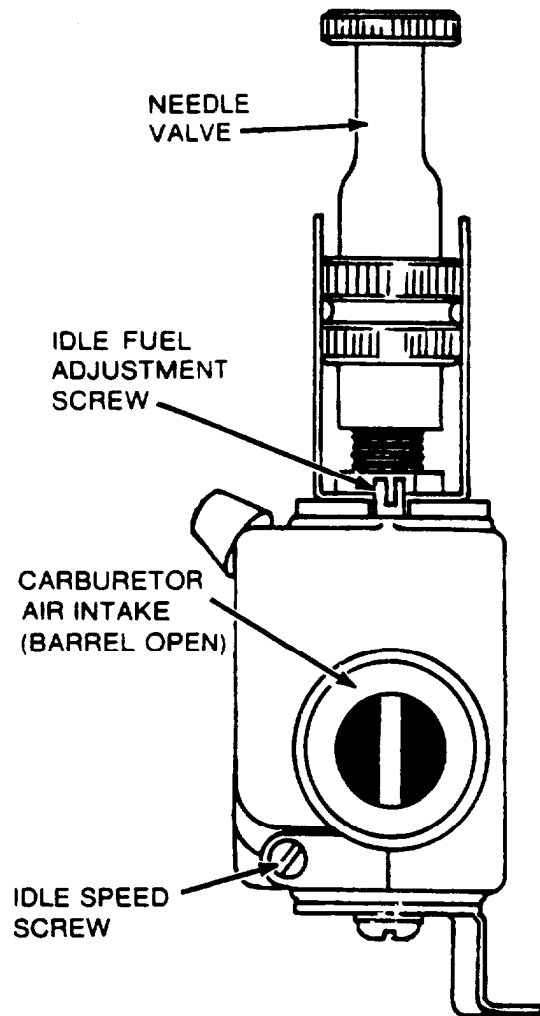

CARBURETOR IN OPEN POSITION

MS619624

Figure 2-16. Carburetor adjustment points.

NOTE

Most engines with a K & B carburetor will idle properly without adjustment to the idle fuel adjustment screw. If adjustment is necessary turn the screw in very small increments. Once idle mixture is adjusted, it will remain at that setting and only the high speed needle valve will need to be adjusted for future flights.

p. Final adjustments are made with the high speed needle for flight. Adjust the needle valve so that the fuel mixture is slightly rich since it will lean out when in flight. Turning the needle valve in a clockwise direction will cause the engine to lean out and counter clockwise will cause the engine to become richer in fuel mixture.

q. Operate the control throttle on transmitter from just above low limit to upper limit. Engine should run smoothly from idle to maximum RPM. If engine coughs or dies, mixture is too rich. Repeat procedures above.

WARNING

The last procedure prior to launching the aircraft consists of verifying that the receiver and servo/battery group is turned on and that the control link between the transmitter and aircraft is operating. If the aircraft is launched without control, a crash will result that may endanger personnel.

It is extremely hazardous to attempt to launch or fly the aircraft when winds are in excess of 25 knots.

Ensure that transmitter antenna is extended to the proper length prior to launch. (See paragraph 2-11a.)

2-15. CONTROL LINK Check.

a. On the transmitter, position controls as follows:

POWER SWITCH	ON
THROTTLE	MAXIMUM
PITCH-TRIM	MID-RANGE
ROLL-TRIM	MID-RANGE
BAND SELECTOR SWITCH	AS REQUIRED
CHANNEL SWITCH	AS REQUIRED
RF SWITCH	AS REQUIRED

NOTE

The battery meter on the transmitter should indicate in the green area. If not, the internal battery requires charging before operation. (For charging procedures, see paragraph 2-22 and 23.)

b. On the receiver and servo/battery group, set the ON-OFF switch to ON and the frequency switch as required.

c. Check operation of ailerons by operating roll portion of control stock and observing action as indicated in roll diagram. (See fig. 2-11.) Check operation of elevators by operating pitch portion of control stock and observing action as indicated in pitch diagram. (See fig. 2-12.)

d. Check operation of throttle by operating the throttle control.

2-16. LAUNCHING TECHNIQUES.

WARNING

Be sure that no personnel other than operators are in the immediate area during operation. The propeller and the area adjacent to each side of the propeller is a danger zone when the engine is running. Keep all personnel away from the propeller. Ensure that clothing does not become tangled in the propeller.

a. The person launching the target will stand to the left and beneath the aircraft. (For visual representation of launch, see figure 2-17.)

b. Grasp the bottom of the fuselage with left, hand slightly ahead of the center in the molded-in grip and grasp the rear of the fuselage with right hand.

WARNING

Never launch or fly the aircraft in the direction of other personnel or toward buildings, structures, or vehicles.

c. Hold the aircraft, upward at a 10 to 20 degree angle and point it in the direction of the launch area. Launch into the wind.

d. Look at target controller and obtain positive indication for release of target.

e. Release grasp of left hand and at the same time guide target forward smoothly with right hand.

f. Launch procedures for the F-16 (FQM-117 C-1) are the same as for the Mig-27 (FQM-117 B-1) as shown in figure 2-17.

2-17. FLIGHT CONTROL.

The aircraft is controlled from the transmitter by the controller. The controller flies the target on a predetermined flight path based on the training mission. Figures 2-19 through 2-27 show typical flight patterns.

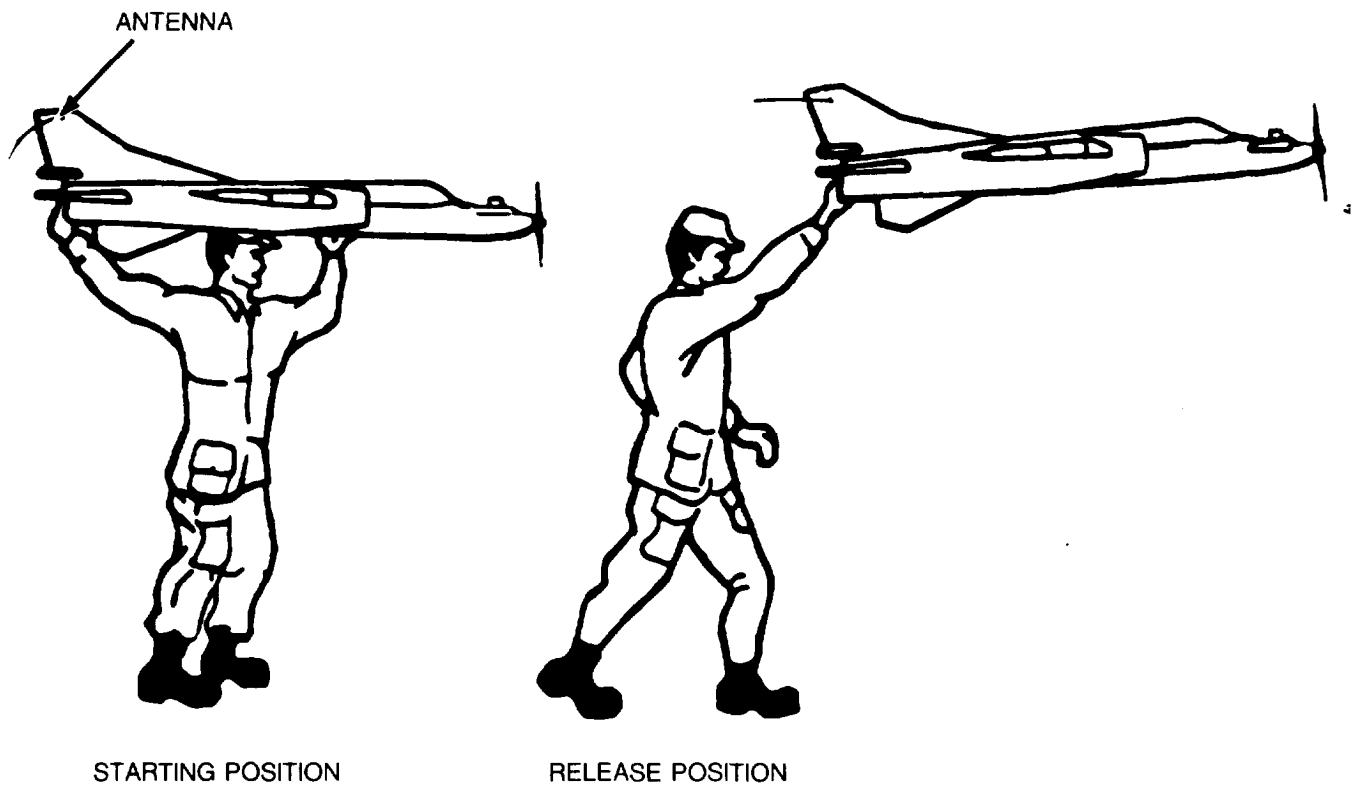

MS619625

Figure 2-17. Launch procedures for FQM-117 B-1.

2-18. FLIGHT PROFILES.

The following flight profiles can be varied to fit gunner proficiency, range, layout, etc. as desired by weapons instructor. These flight profiles are based on attack techniques and are designed to offer the gunner the most realistic target possible. All distances have been stated in 1/9 scale to fit the scale speed and size of the aircraft. A range layout (fig. 2-18)

is also included to illustrate the training that can be realized utilizing a small area to fly the small scale visually guided aerial target against the many air defense type weapons in the U.S. arsenal. The flying area is approximately 2 kilometers wide and 1 kilometer deep. There is a safety no-flying zone anywhere in front of the weapons closer than 50 meters. Weapons should not be fired at the target during takeoff or on landing.

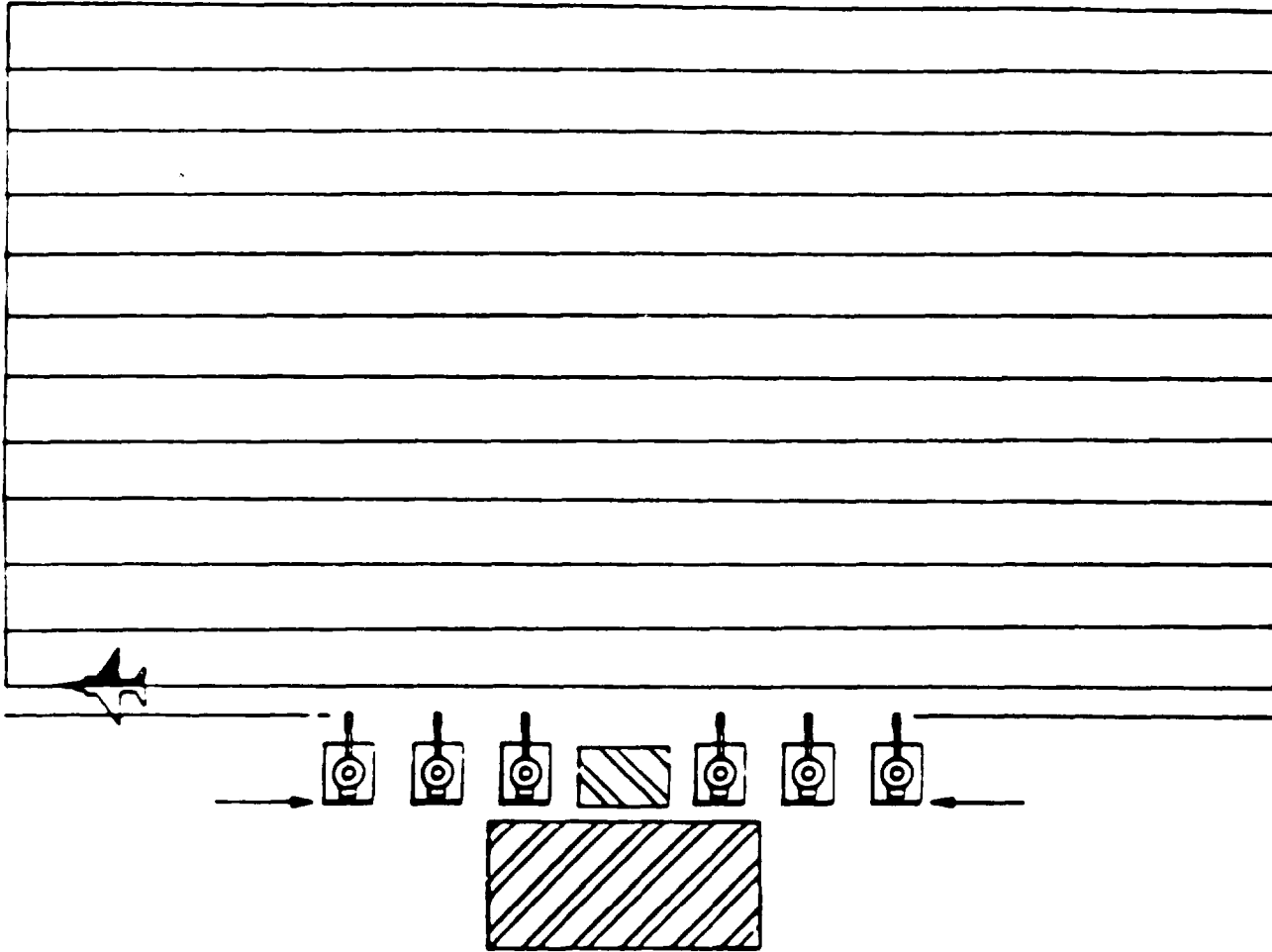

MS619626

Figure 2-18. RCMAT range plan.

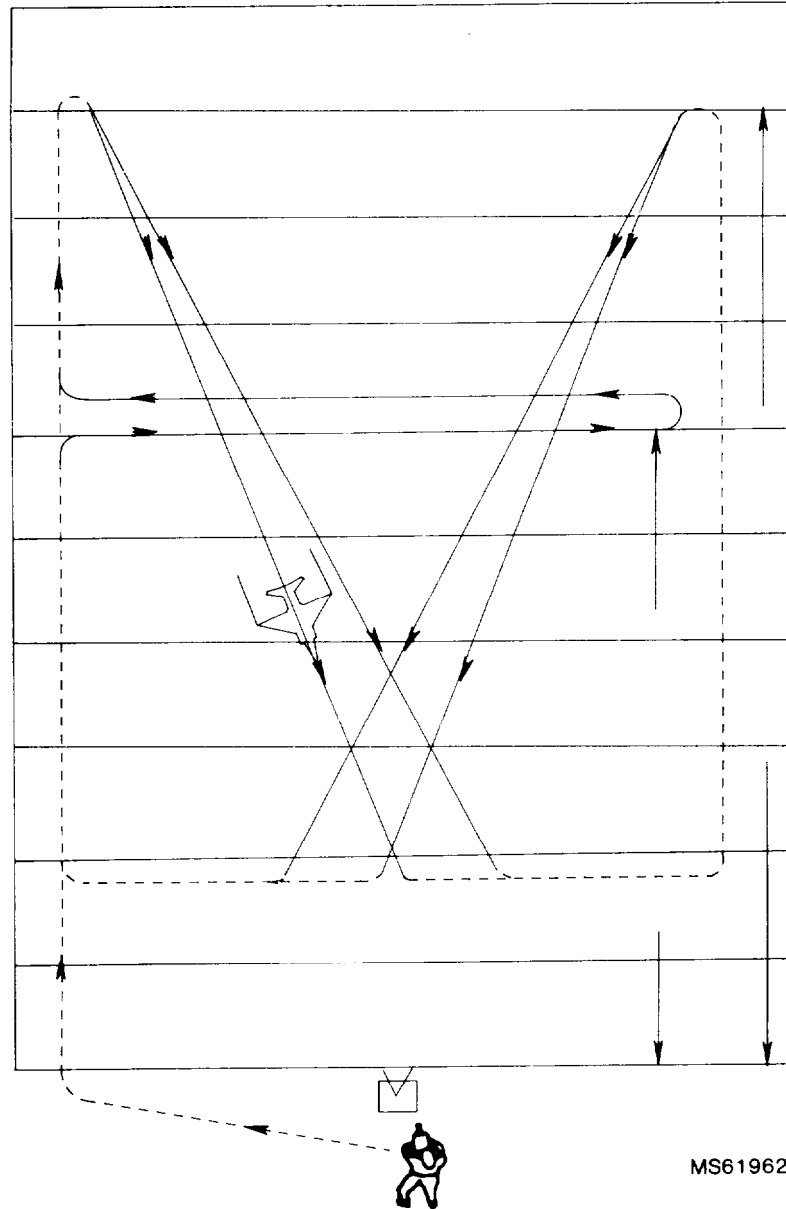
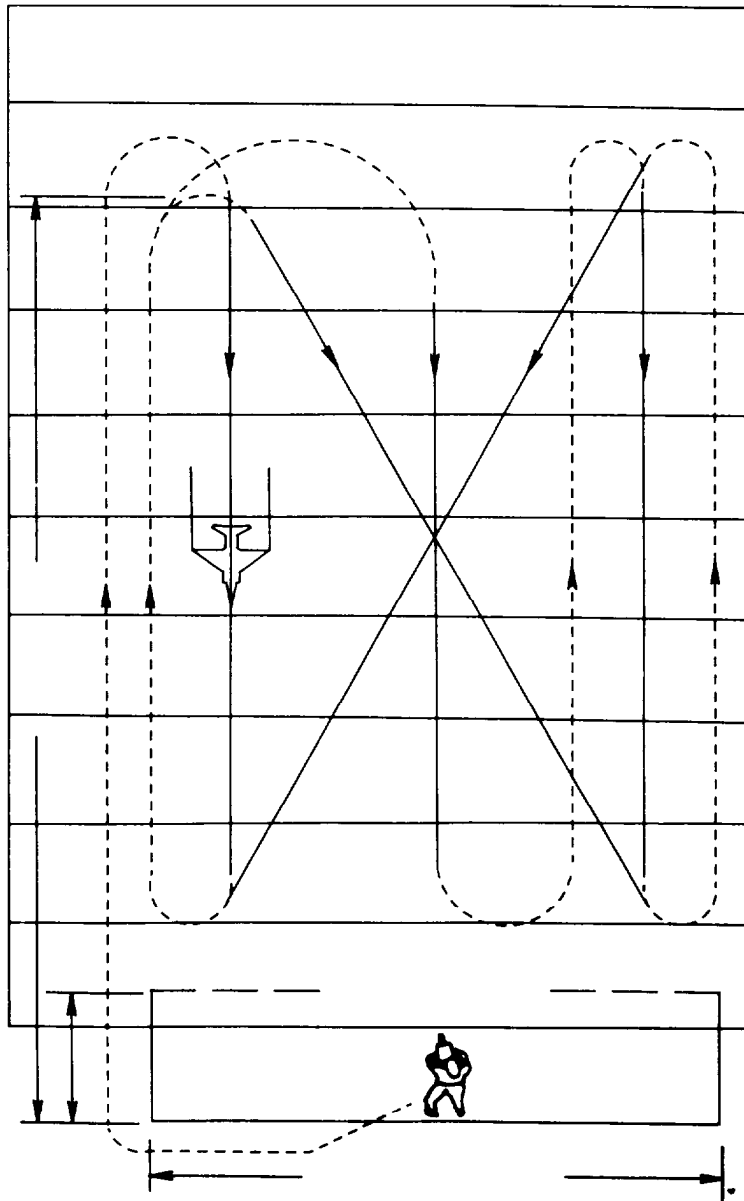

Figure 2-19. Primary sample pattern for small arms air defense.

This range setup is primarily for small arms training and the size of the range is variable. Recommended area is approximately 250 meters wide and 500-600 meters deep. There is a 50 meter no-fly line in front of the firing line, and no targets

should be engaged during takeoff or landing. Patterns flown can be varied to suit the weapons instructor, the experience factor of the target controller, and the visibility limits.

————— INCOMING
 - - - - - OUTGOING



MS619628

Figure 2-20. Alternate sample pattern for small arms air defense.

This range set up is primarily for small arms training and the size of the range is variable. Recommended area is approximately 250 meters wide and 500-600 meters deep. There is a 50 meter no-fly line, and no targets should be engaged during

takeoff or landing. Patterns flown can be varied to suit the weapons instructor, the experience of the target controller, and the visibility limits.

————— INCOMING
 - - - - - OUTGOING

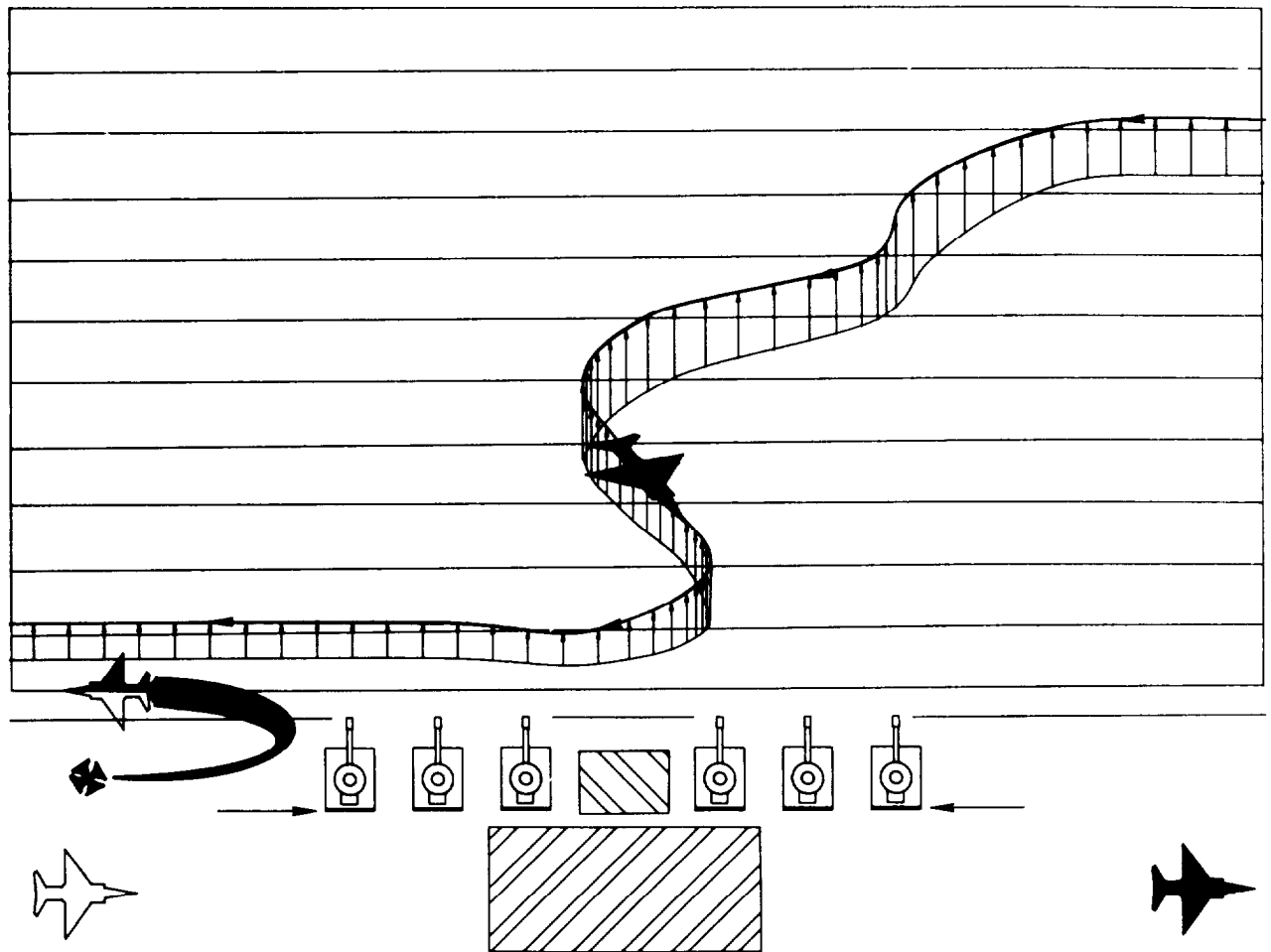

MS619629

Figure 2-21. Strafing pattern.

The strafing run consists of an approach at low altitude (50-60 feet) to an aiming point approximately 180 feet from the target. The aircraft dives at a 10 degree angle to a break point

50-60 feet from the target at an altitude of 40-50 feet. The aircraft then escapes at high speed and low altitude.

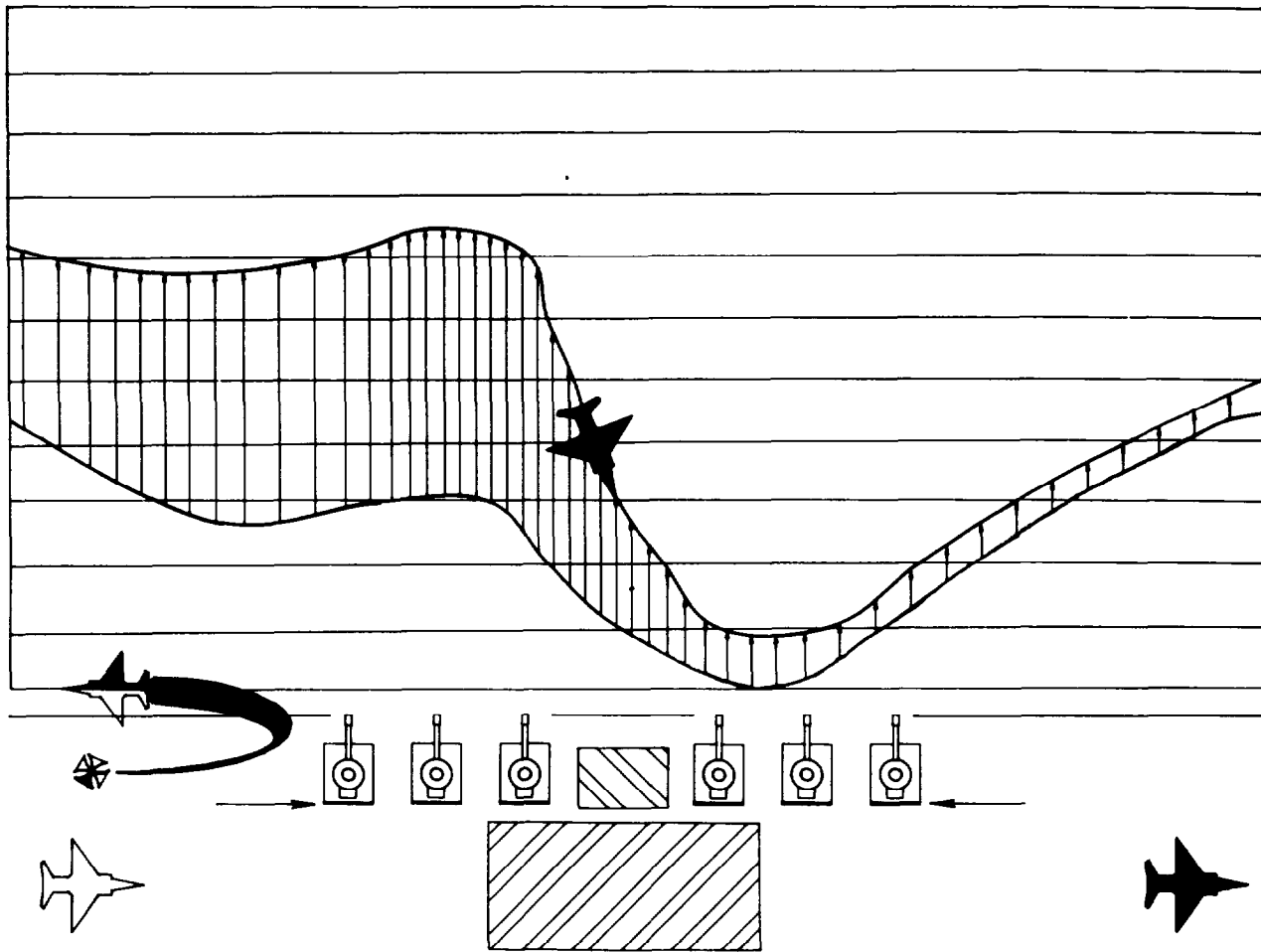

MS619630

Figure 2-22. Dive bombing pattern.

The dive bomb run consists of a high altitude (500ft.) run from an initial point. Aircraft dives at a 10 to 45 degree angle toward

target, attacks, pulls out, and escapes at high speed and low altitude.

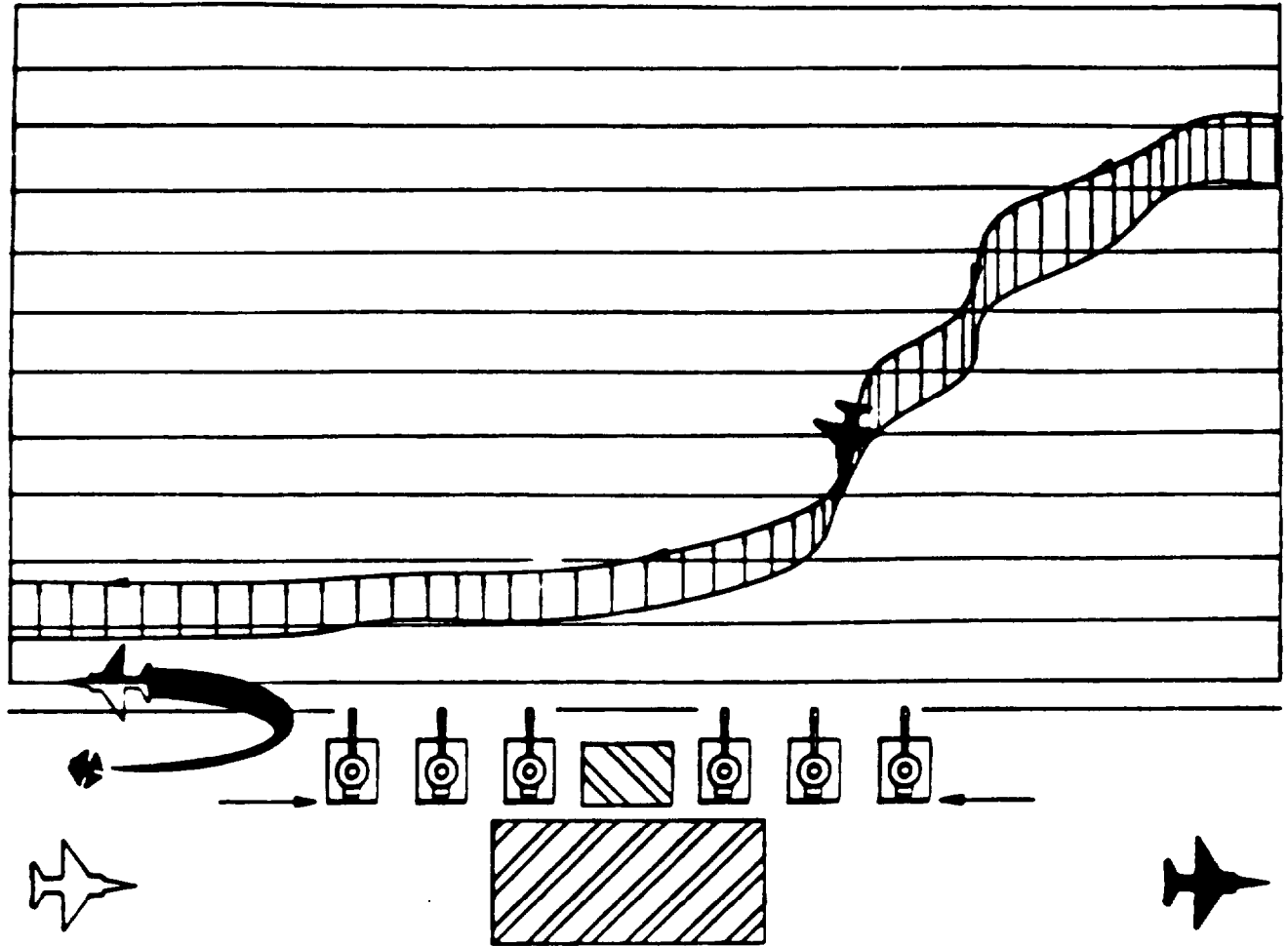

MS619631

Figure 2-23. Low-level penetration laydown pattern.

This technique is frequently used by fighter aircraft to deliver ordnance on troops in the field. The pilot flies the aircraft about 50 feet above the ground level. The target course is over the target area. High speed and low altitude increase the probability of success on the mission. The ability to release

ordnance at such low altitudes is made possible by advances in the development of retardation devices. The falling speed of ordnance is reduced by drogue chutes or retarding fins. This allows the aircraft to get out of the way before detonation occurs.

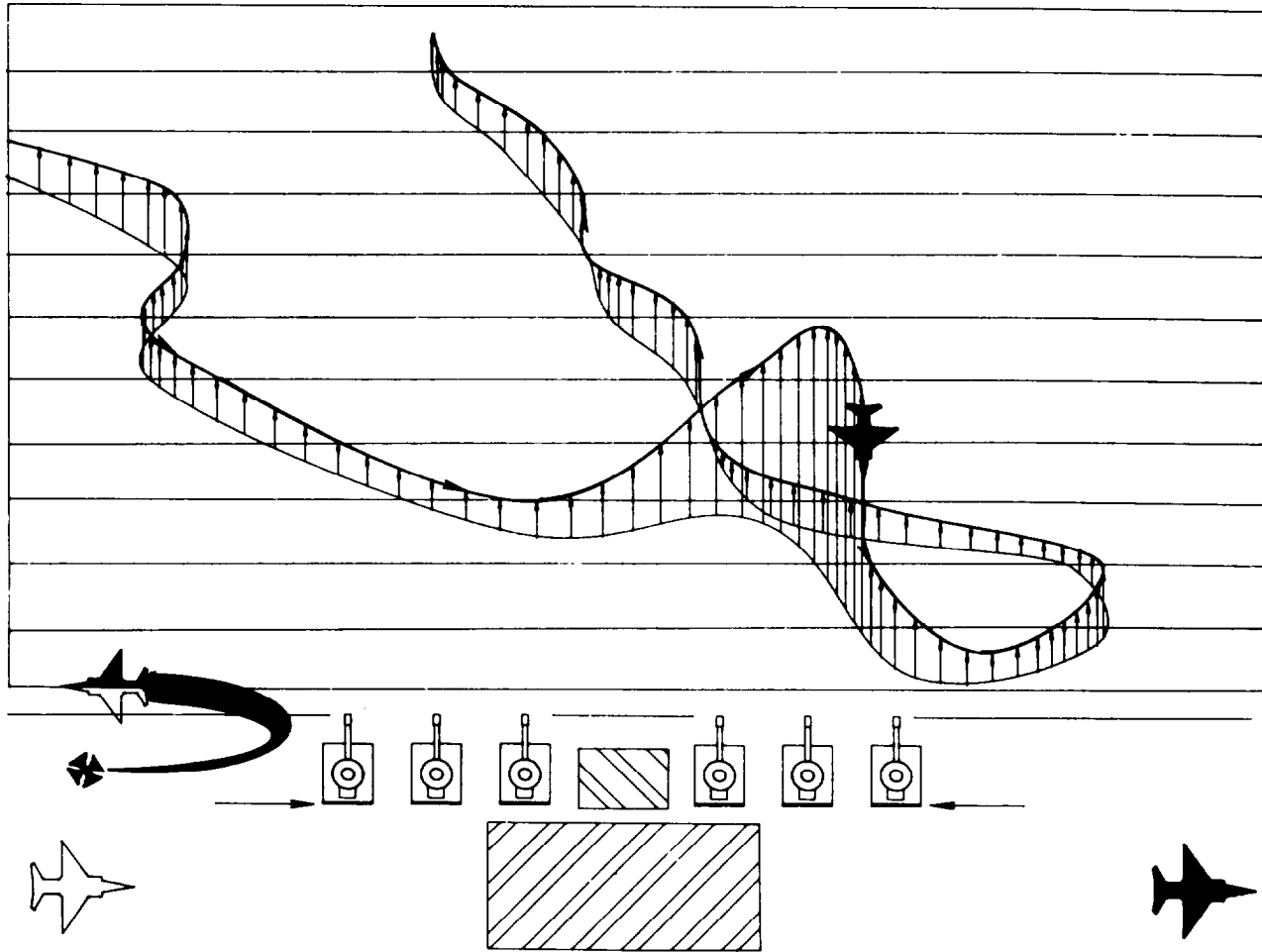

MS619632

Figure 2-24. Low-level penetration pop-up pattern.

The pop-up consists of a run in at low level (approximately 50-60 feet) from an initial point using natural terrain features to achieve surprise. Aircraft flies from initial point to a pullup point offset from target and then commences to climb to attack

height (approximately 200-250 feet). Aircraft wings over between 45 and 100 degrees left or right of the original track for initial point to pullup point. Aircraft escapes at high speed and low altitude (approximately 50 to 75 feet).

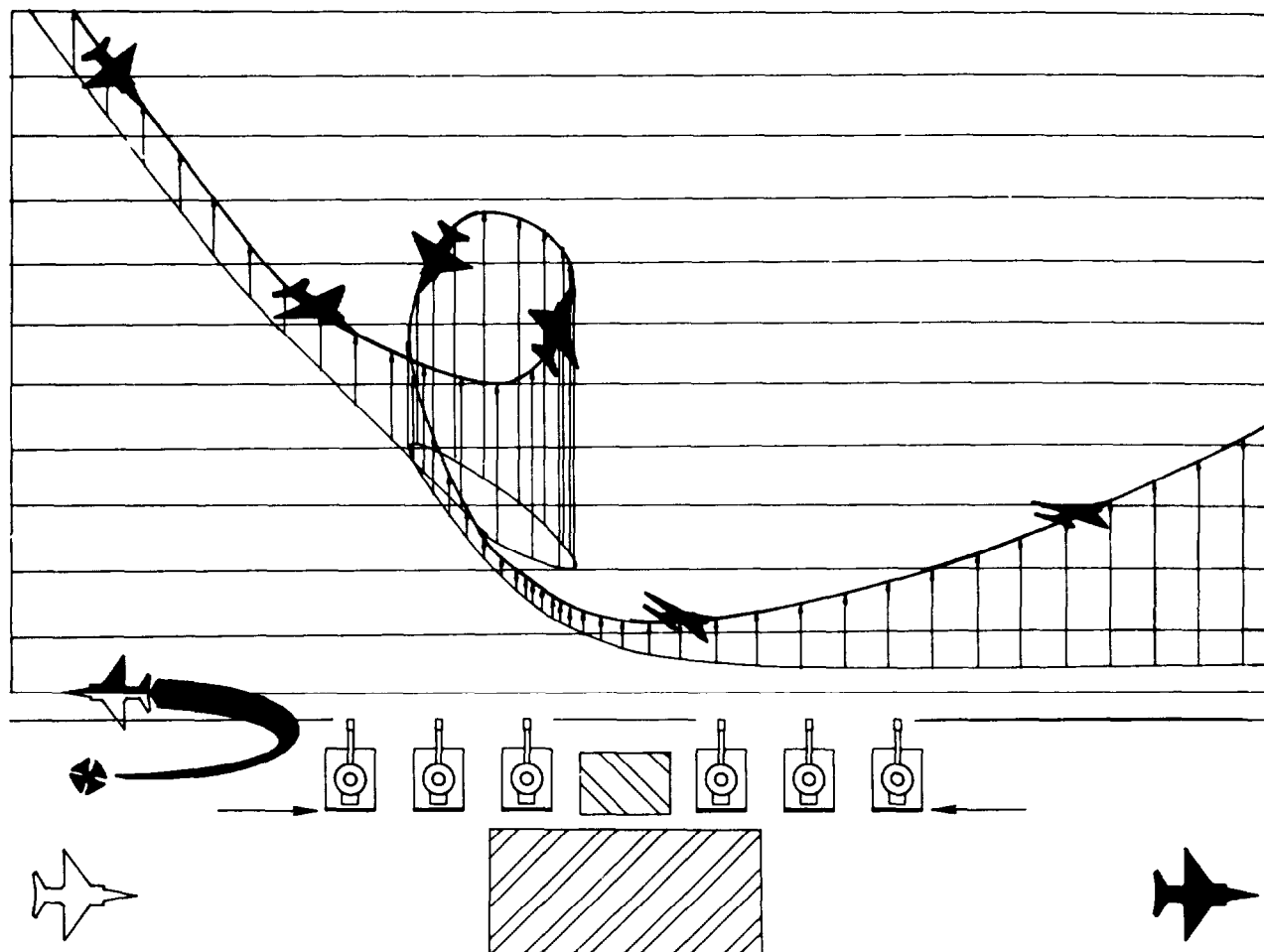

MS619633

Figure 2-25. Attack from the "loop" pattern.

The attack from the loop pattern begins in almost the same pattern as the low level popup, except the aircraft remains low (approximately 50-60 feet) until approximately 300 feet of the target. Then it executes a steep climb, inside loop, and dives

on the target. After ordnance delivery, aircraft breaks off suddenly and escapes at high speed and low altitude using ground terrain features for cover.

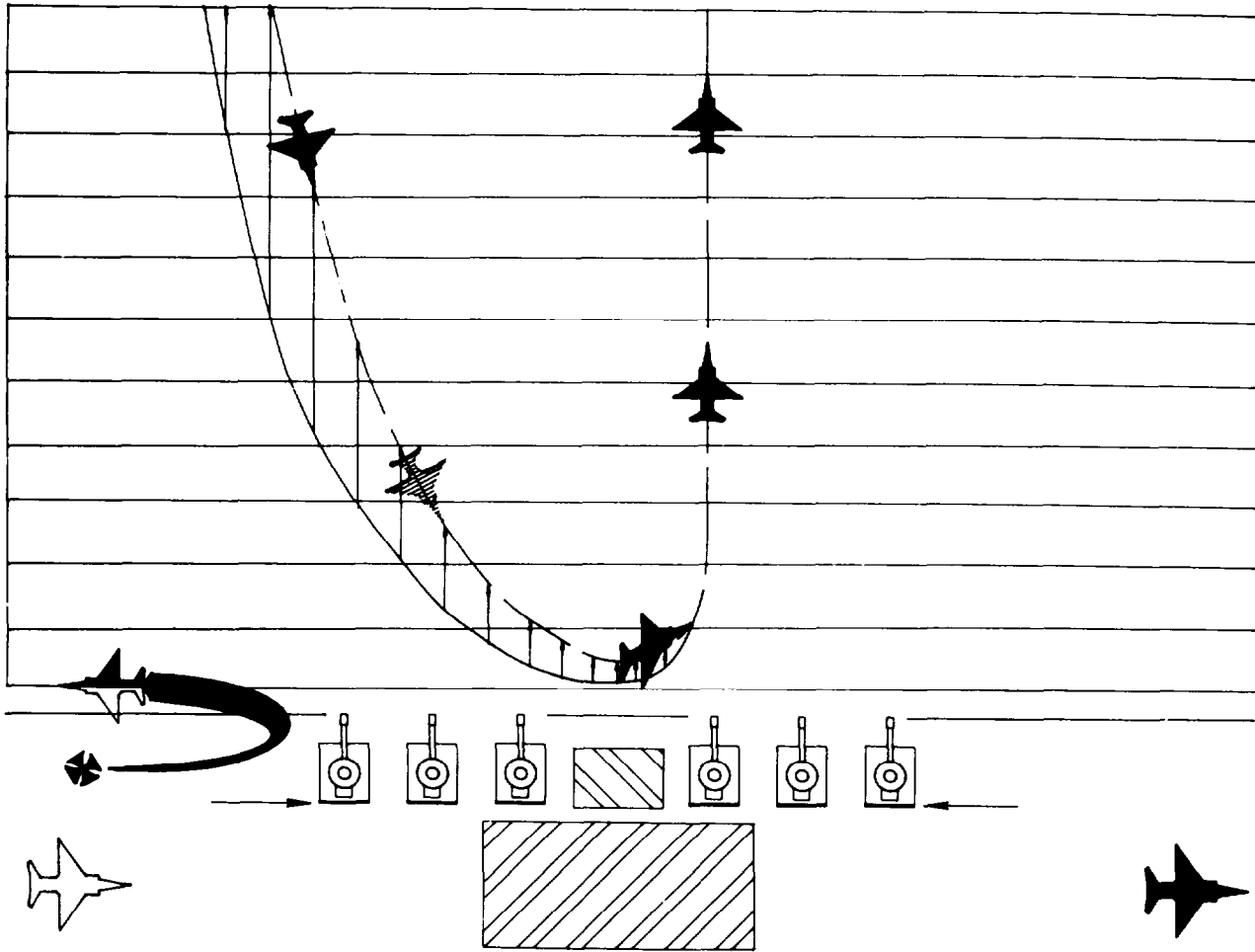

MS619634

Figure 2-26. Pitch-up bombing pattern.

The pitch-up bombing attack makes an almost straight in attack on the target at approximately 100-150 feet. When approximately 150 feet from the target, the aircraft pulls up

sharply, releases its bomb, breaks off the attack, and escapes at low altitude and high speed. The inertia of the bomb will carry it to the target.

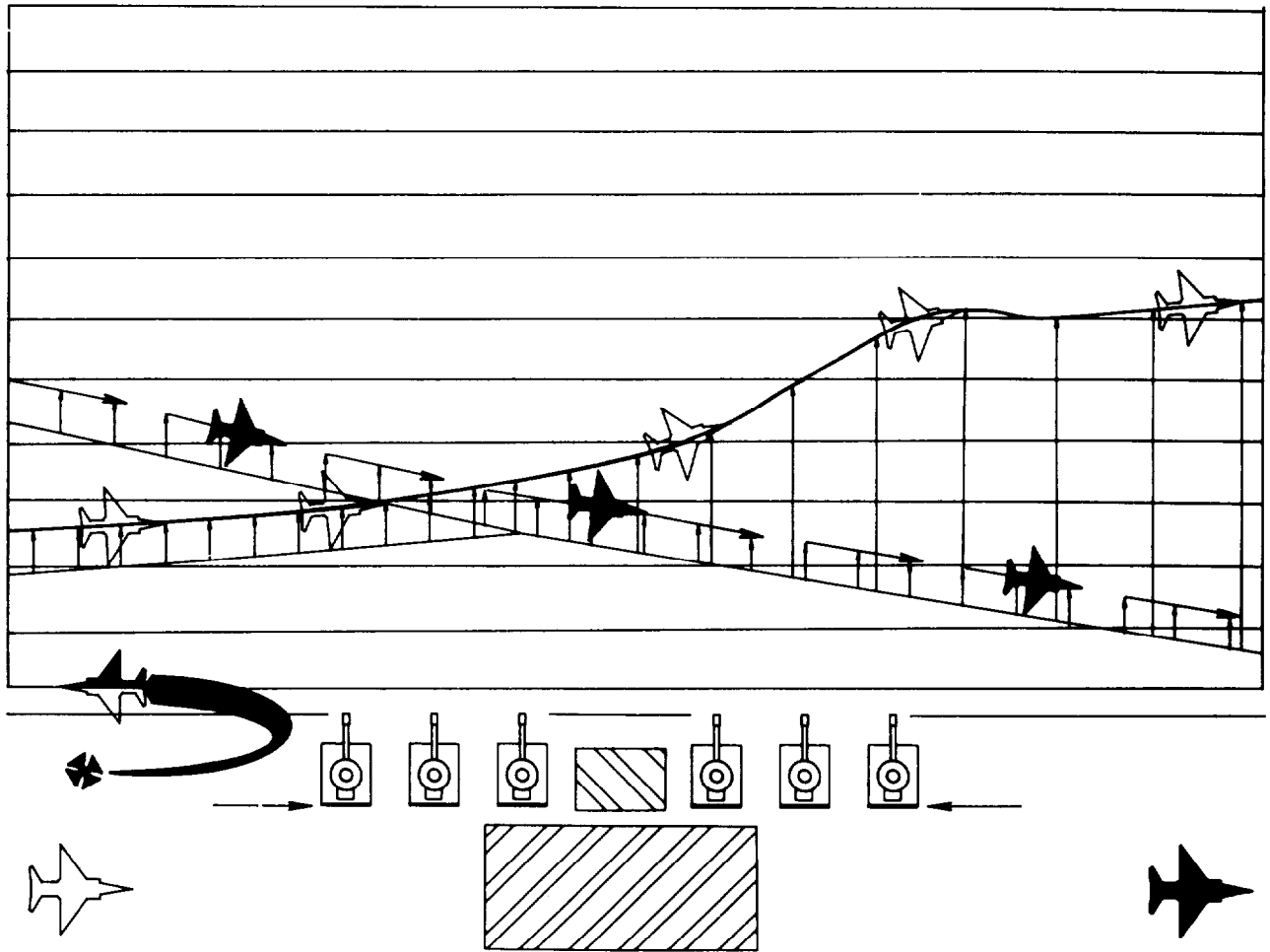

MS619635

Figure 2-27. Multiple aircraft pattern (sheet 1 of 2).

The multiple aircraft pattern is a diversionary tactic. It consists of a decoy flight of aircraft approximately 10-15 seconds in front of another flight. The decoy's purpose is to draw the attention of the weapon controllers. No attack is made by the

diversionary aircraft. However, while attention is drawn to them, a second flight of aircraft arrives and attacks the target's position, allowing very little time for the gunners to react to the actual attack.

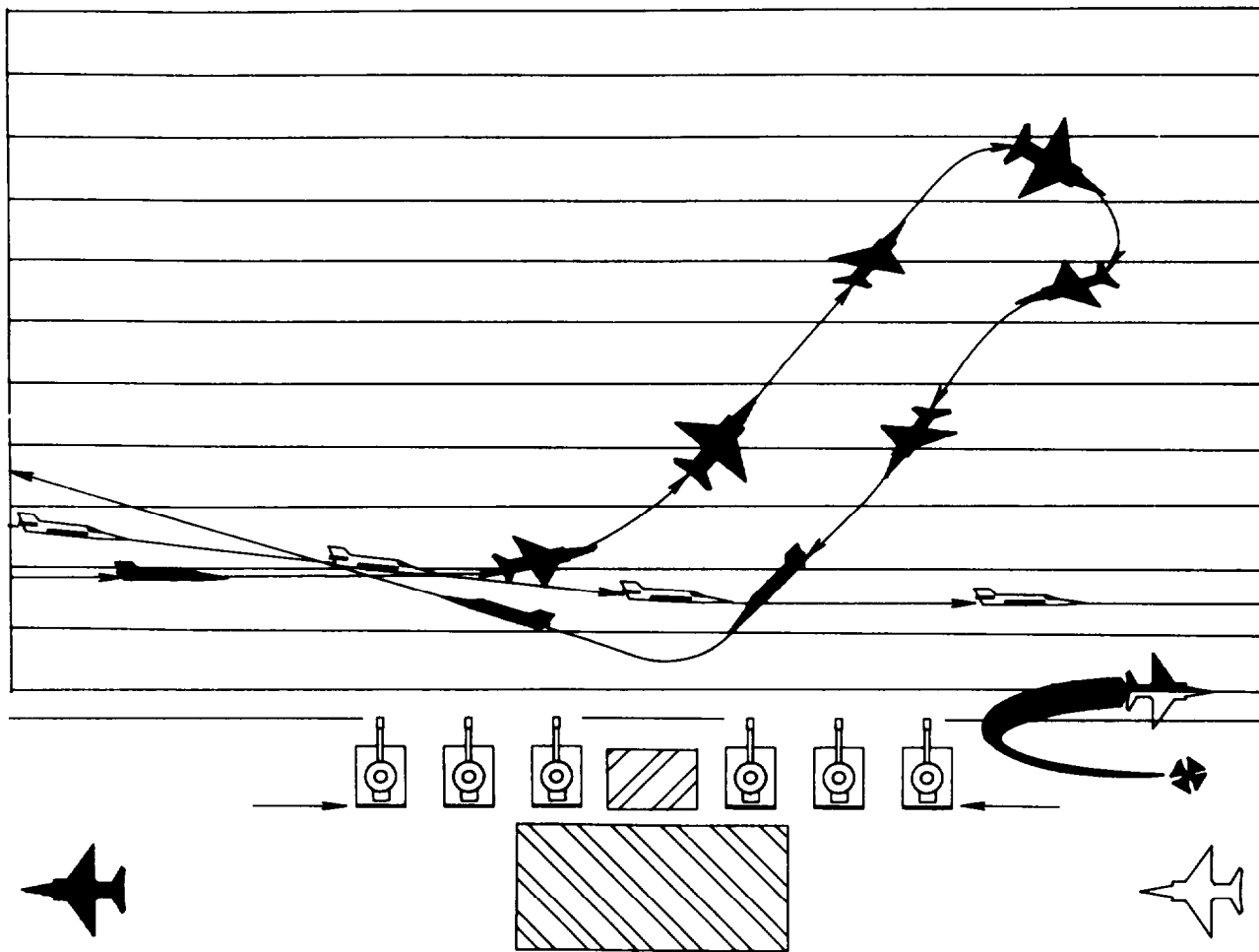

MS619636

Figure 2-27. Multiple aircraft pattern (sheet 2 of 2).

Another version of the multiple aircraft pattern is for the lead flight of aircraft to appear as if it's not going to attack; however, when the second flight of aircraft arrives, it flies

past the target without attacking. The first flight of aircraft executes a 180-degree turn and attacks the target.

2-19. LANDING THE FQM-117 B-1 & FQM-117 C-1.

CAUTION

The landing procedure requires practice. Landing should be performed with minimum damage to the aircraft. If possible, never land the aerial target while the engine is running as the propeller will be broken.

- a. Note current wind direction. Fly the aircraft into the wind toward the landing zone. Gradually reduce flying speed to reduce altitude.
- b. As the aircraft settles toward the landing zone, set throttle control to minimum to stop the engine. If this fails to stop the engine, continue to fly until the fuel is exhausted. To avoid a stall and crash, keep the target slightly nose-down in a glide. Do not pull the nose up with the power off, unless speed is too great for landing.
- c. At approximately 2 to 3 feet above the ground, gradually lift the nose (flare out) by pulling back on the pitch-roll control stick. Now in a controlled stall, the aircraft will settle.
- d. Keep the aircraft slightly nose-up until it settles to the ground.

2-20. STANDBY PROCEDURES.

NOTE

The standby procedure lists the actions necessary to put the aircraft into a standby condition so that it may be launched again with minimum preparation.

- a. Perform the following standby procedures:
 - (1) Set receiver power switch to OFF.
 - (2) Set transmitter power switch to OFF.
 - (3) Replenish the fuel. (For fueling procedures, see paragraph 2-13.)
 - (4) Pinch off both fuel lines using the hemostat supplied in the GSE field box to prevent leakage for the tank. (See fig. 2-28).
 - (5) Fast charge the transmitter and receiver and servo/battery group batteries, if absolutely necessary. (For battery checking and charging procedures, see paragraph 2-22 and 2-23.)
 - (6) Check propeller for damage.
 - (7) Inspect airframe and engine for loose hardware and damage.
- b. For restarting and flying the aircraft, see paragraphs 2-14, 15, and 16.

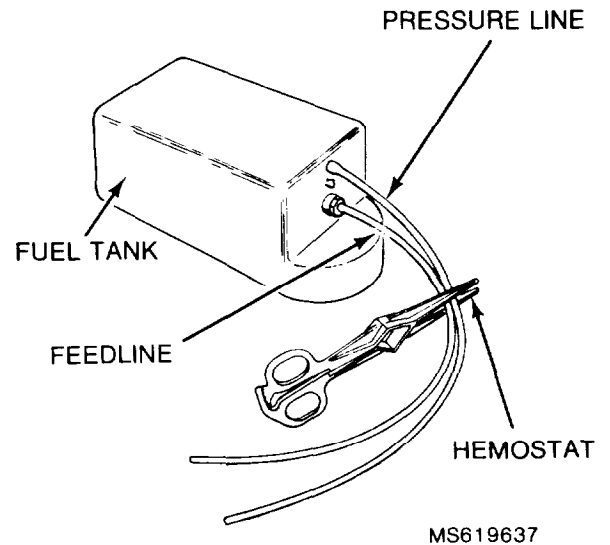
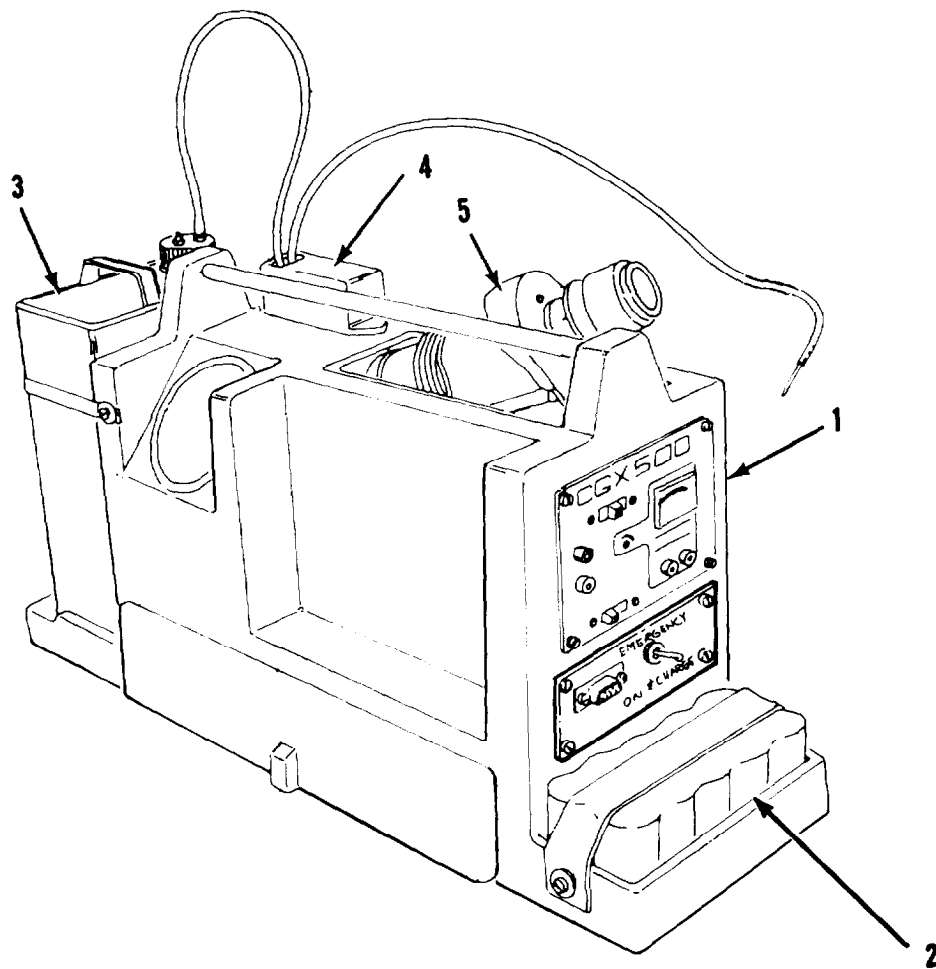

Figure 2-28. Fuel tank closure procedure.

2-21. OPERATION OF GROUND SUPPORT EQUIPMENT (GSE).

- a. The GSE is divided into two major components: the field box and the charger. The GSE field box provides the equipment and the tools for supporting the operation of the FQM-117 B-1 and FQM-117 C-1 (See fig 2-29.) The GSE charger performs both the fast and slow charging of the receiver and servo/battery group batteries, transmitters and GSE field box batteries. (See fig. 2-30.)
- b. For procedures utilizing the GSE emergency power cable for the transmitter are paragraph 2-24 and figure 2-37.
- c. For procedures utilizing the GSE emergency power cable for the GSE field box, see paragraph 2-24 and figure 2-36.
- d. For procedures utilizing transmitter trainer cord, see paragraph 4-12 and figure 4-6.
- e. For procedures utilizing the fuel pump, see paragraph 2-13 and figure 2-14.
- f. For procedures utilizing the starter, see paragraph 2-14 and figure 2-15.
- g. For transmitter and GSE battery charging procedures, see paragraph 2-22 and figures 2-31 through 2-33.
- h. For receiver and servo/battery group charging procedures, see paragraph 2-23 and figures 2-34 and 2-35.
- i. For external 12Vdc emergency power cable operation of the GSE field box and transmitter, see paragraph 2-24 and figures 2-36 and 2-37.



MS619638

- 1 GSE field box
- 2 Battery
- 3 Fuel can
- 4 Fuel pump
- 5 Starter

Figure 2-29. Ground support equipment (GSE) field box components and location.

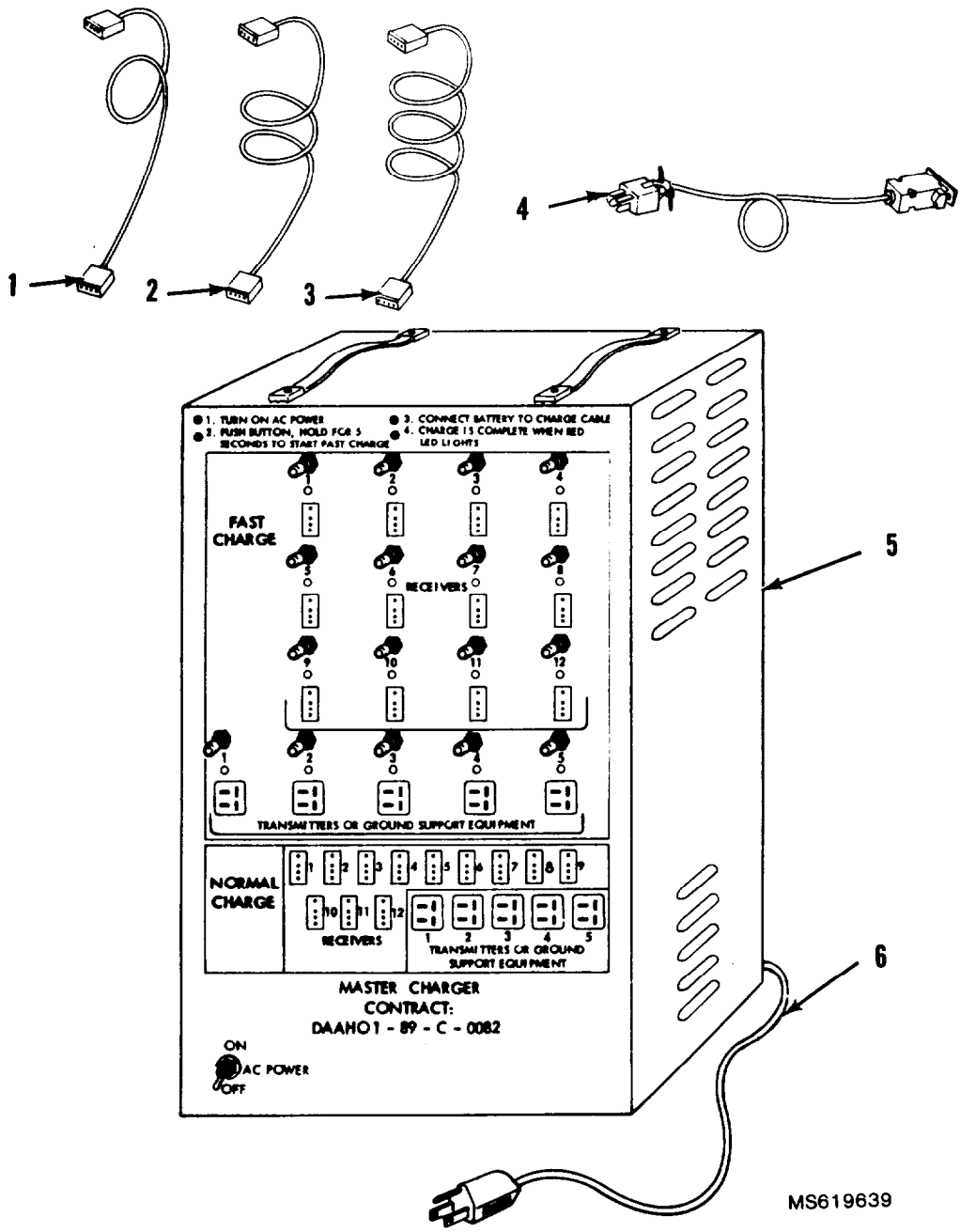

- 1 Flight pack short cables (4 each)
- 2 Flight pack medium cables (4 each)
- 3 Flight pack long cables (4 each)
- 4 Ground support and transmitter cables (5 each)
- 5 Charger
- 6 110 Vac power cord

Figure 2-30. Ground support equipment (GSE) charger components and location

2-22. BATTERY CHARGING PROCEDURES FOR TRANSMITTER AND GROUND SUPPORT EQUIPMENT (GSE) FIELD BOX BATTERIES.

- a. Check the battery voltage level.
 - (1) Charge the transmitter battery if the voltage level is below 12 volts. Use the multimeter supplied with the GSE to determine the transmitter battery voltage. (See fig. 2-31.)

CAUTION

Constant fast charging tends to deteriorate nicad batteries in a very short time. Do not use fast charging unless it is absolutely necessary.

NOTE

One, two or three transmitters and one or two CSE field box batteries may be charged (either fast or standard) simultaneously or individually.

The GSE charger, when utilized for charging the FQM-117 B-1 and FQM-117 C-1, system batteries (both standard and fast charging) must be connected to a 110-120 Vac power source.

When charging is complete, disconnect the equipment from the charger to prevent discharge when the charger is switched off.

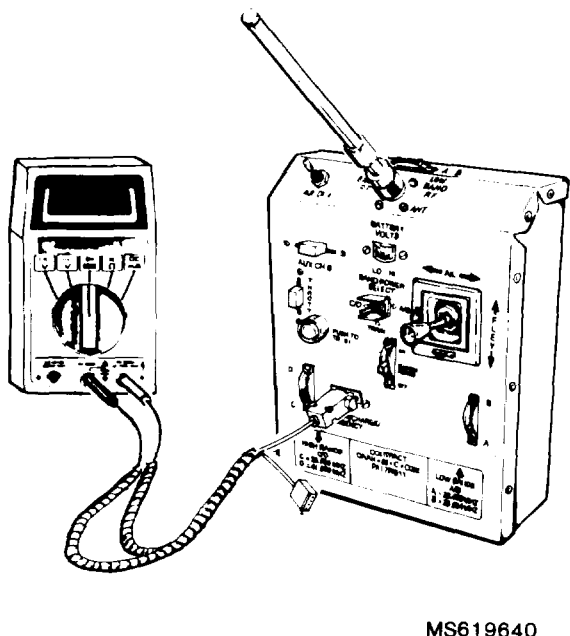

Figure 2-31. Voltage checking of transmitter.

- (2) Charge the GSE field box battery if the voltage level is below 12 volts. Use the multimeter supplied with the GSE to determine the GSE field box battery voltage. (See fig. 2-32.)

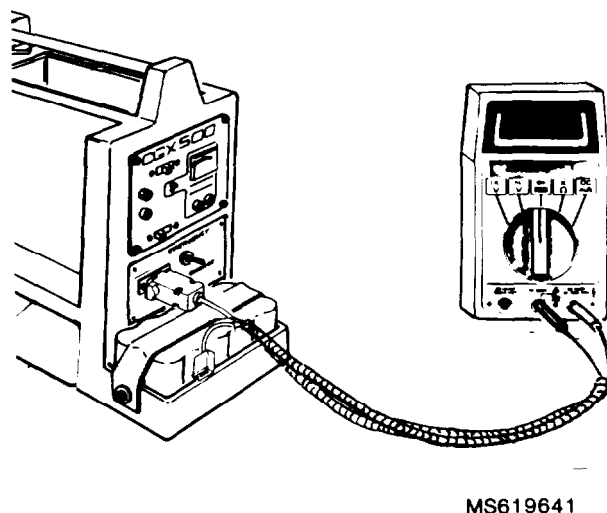

Figure 2-32. Voltage checking of GSE field box battery.

WARNING

During charging procedures, the metal portions of the ground support equipment charger case will become hot. Avoid contact with the heated surface as burns could result.

- b. Obtain the following equipment to perform the battery charging procedures.

- One to three transmitters
- One or two GSE field boxes
- GSE charger
- Charge cables

c. Perform the battery charge procedures as outlined below. (See fig. 2-30 and 33.)

- (1) Ensure GSE charger power switch is set to OFF.
- (2) Connect GSE charger to 110-120 Vac power source using the 110 Vac power cord (6).

(a) Connect male connector of 110 Vac power cord to 110-120 Vac power source.

- (3) Ensure transmitters are set to OFF.
- (4) Ensure that the GSE field box charge/emergency switch is set to charge.

(5) Connect charge cables to each of the batteries to be charged. In the case of the transmitters, use the TRAINER/CHARGE/EMERGENCY plug. In the case of the GSE field box battery, use the CHARGE/EMERGENCY plug.

(6) Connect the other end of the charge cables to the appropriate fast or normal charge receptacles on the GSE charger. Before fast charging, charge battery on normal charge for five minutes.

(7) Set GSE power switch to ON and charge batteries.

(a) For standard rate (overnight) charge, allow batteries to charge for at least 14 hours.

(b) For fast charging, turn on ac power, push button above receptacle for five seconds to start fast charge and then connect battery to charge cable. The fast charge is complete when the LED above the receptacle lights. No harm to the batteries will result if they are not removed from the charger after the LED lights. The GSE charger automatically stops charging after the LED lights.

(8) Set GSE power switch to OFF.

(9) Check battery voltage level. (See fig. 2-31 and 32.)

(a) If properly charged, the battery is ready to use.

(b) If battery will not charge after standard rate charging, discard battery.

(10) Disassemble charge cables and store with the GSE charger.

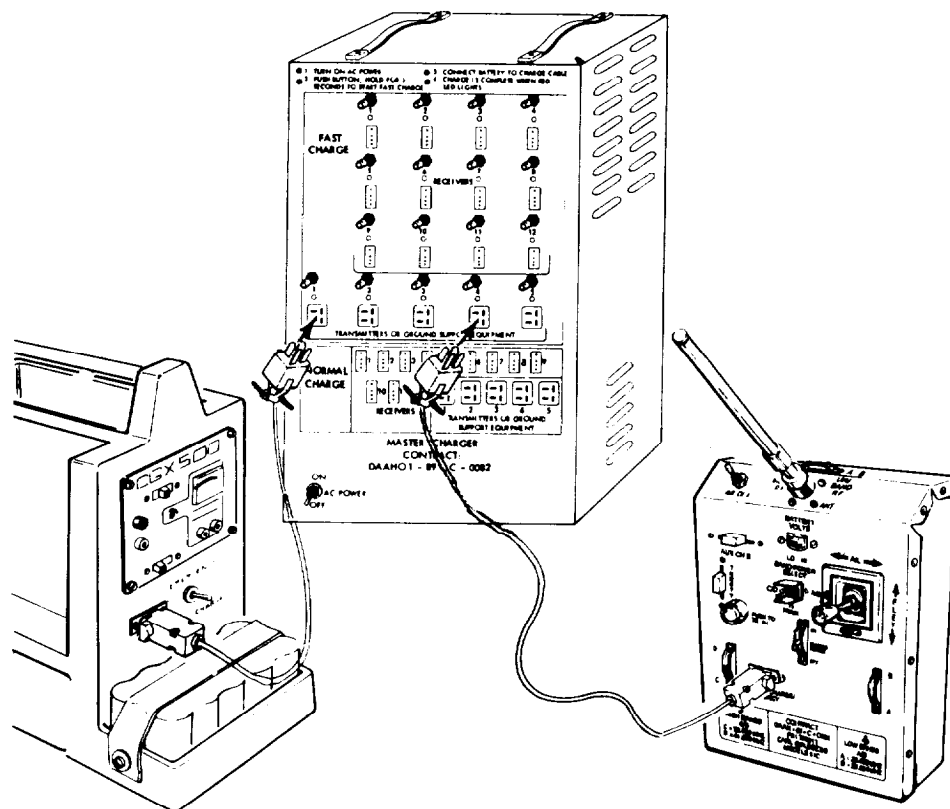

MS619642

Figure 2-33. Battery charging for transmitter and GSE batteries.

2-23. BATTERY CHARGING PROCEDURES FOR RECEIVER AND SERVO/ BATTERY GROUP BATTERIES.

a. Check the voltage level. Charge the receiver and servo/battery group battery if the voltage level is below 4.8 volts Use the multimeter supplied with the GSE to determine the receiver and servo/battery group battery voltage. (See fig. 2-34.)

WARNING

During charging procedure, the metal portions of the ground support equipment charger case will become hot. Avoid contact with the heated surface as burns could result.

CAUTION

Constant fast charging tends to deteriorate nicad batteries in a very short time. Do not use fast charging unless it is absolutely necessary.

NOTE

One through twelve receiver and servo/battery group batteries may be charged (either fast or standard) simultaneously or individually.

The GSE charger, when utilized for charging the FQM-117 B-1 and the FQM-117 C-1 system batteries (both standard and fast charging), must be connected to a 110-120 vac power source.

When charging is complete, disconnect the equipment from the charger to prevent discharge when the charger is switched off.

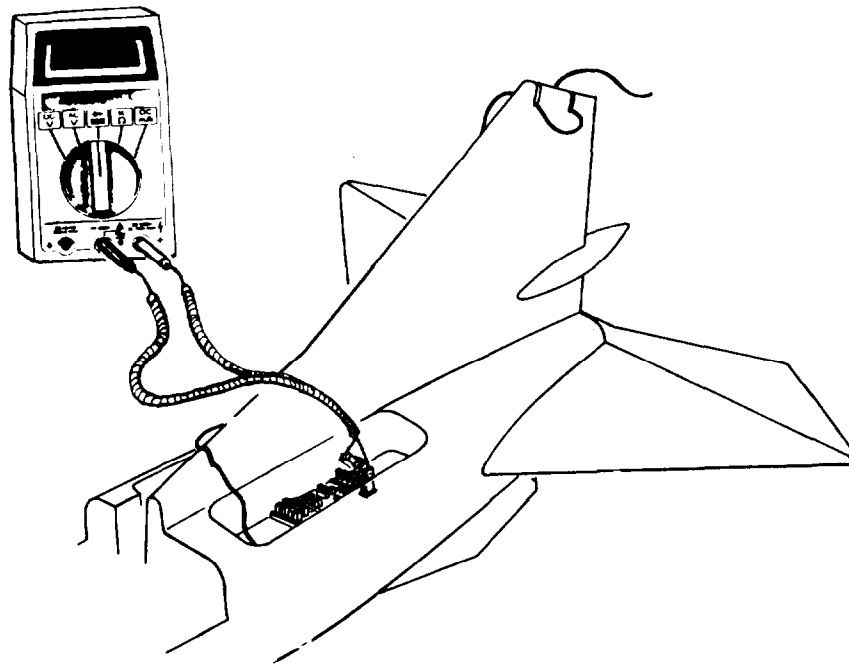

MS619643

Figure 2-34. Voltage checking of the receiver and servo/battery group battery.

b. Obtain the following equipment to perform the battery charging procedures:

- 1 to 12 Receiver and servo/battery group batteries
- GSE charger
- charger cables

c. Perform the battery charging procedures as outlined below. (See fig. 2-35.)

- (1) Ensure GSE charger power switch is set to OFF.
- (2) Connect GSE charger to 110-120 Vac power source using the 110 Vac power cord (6).
- (3) Ensure that the receiver power switch is set to OFF.
- (4) Connect charger cables to each of the receiver charging connectors. (See fig. 2-35.)
- (5) Connect the other end of the charge cables to the appropriate fast or normal charge receptacles on the GSE charger. Before fast charging, charge battery on normal charge for five minutes.

(6) Set GSE charger power switch to ON and charge batteries.

(a) For standard rate (overnight) charge, allow batteries to charge at least 14 hours.

(b) For fast charging, turn on ac power, push button above receptacle for five seconds to start fast charge and then connect battery to charge cable. The fast charge is complete when the LED above the receptacle lights. No harm to the batteries will result if they are not removed from the charger after the LED lights. The GSE charger automatically stops charging after the LED lights.

(7) Set GSE charger power switch to OFF

(8) Check battery voltage level. (See fig. 2-34.)

(a) If properly charged, the battery is ready to use.

(b) If battery will not charge after standard rate charging, discard battery.

(9) Disassemble charge cables and store with the GSE charger.

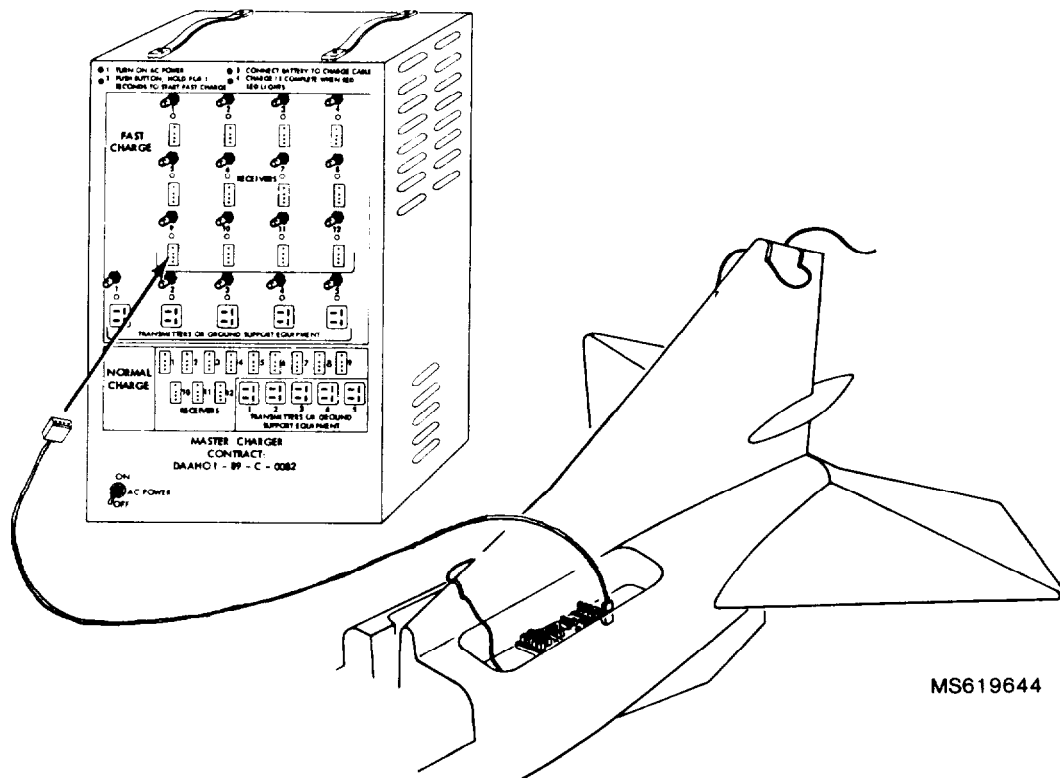

MS619644

Figure 2-35. Battery charging for receiver and servo/battery group batteries.

2-24. UTILIZATION PROCEDURES FOR THE GSE FIELD BOX AND TRANSMITTER EXTERNAL 12 VDC EMERGENCY POWER CABLE.

NOTE

The external 12Vdc emergency power cable is a back up means of applying power to the GSE field box or the transmitter in the event of an extremely long period of field operations where 110 Vac is not available to recharge the GSE field box battery or the transmitter.

a. Obtain the emergency power cable from the GSE field box storage drawer and an appropriate source of 12 Vdc power.

b. Perform the following procedures to use an external 12 V dc power source to power the GSE field box. (See fig. 2-36.)

(1) Ensure that the GSE field box charge/emergency switch is set to emergency.

(2) Connect the external 12 Vdc power cable connector to the CHARGE/EMERGENCY connector.

CAUTION

Be careful to observe proper polarity when connecting the power cable alligator clips to the 12 Vdc power source.

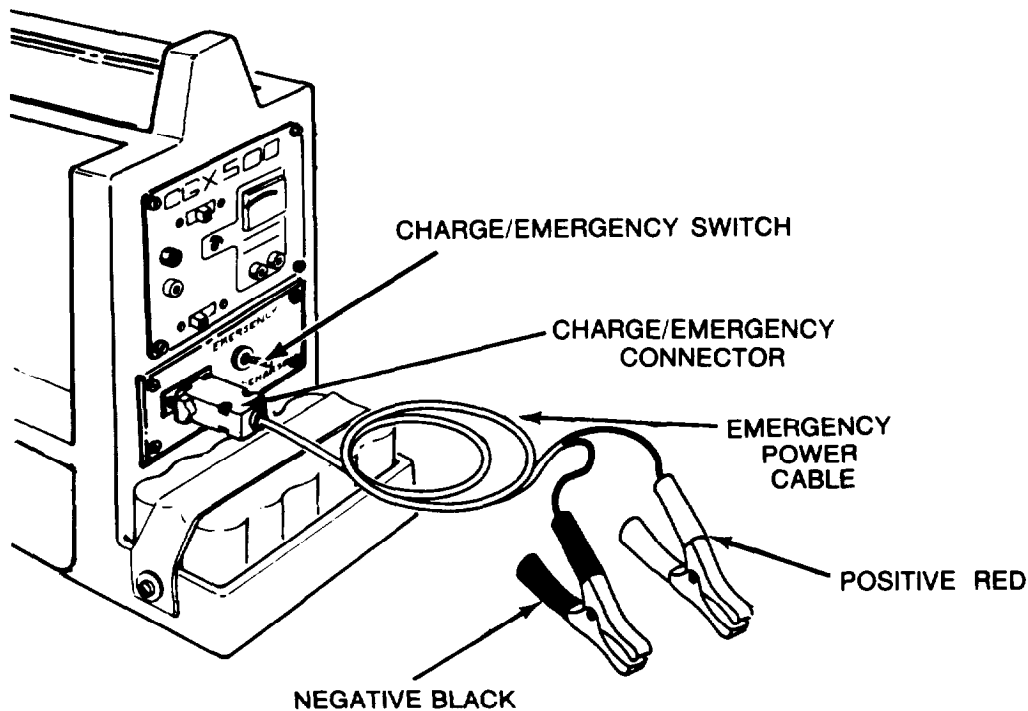

MS619645

Figure 2-36. External 12 Vdc emergency power cable operation of the GSE field box.

(3) Connect the alligator clips of the external 12 Vdc emergency power cable to any appropriate source of 12 Vdc power being careful to observe proper polarity. The alligator clips are color coded to indicate which is the positive connector (red) and which is the negative connector (black).

(4) Resume operation of the GSE field box in the same manner as when it was connected to its own source of 12 vdc power.

c. Perform the following procedures to use an external 12Vdc power source to power the transmitter. (See fig. 2-37.)

(1) Connect the external 12 Vdc emergency connector to the transmitter TRAINER/CHARGE/ EMERGENCY connector.

CAUTION

Be careful to observe proper polarity when connecting the power cable alligator clips to the 12 vdc power source.

(2) Connect the alligator clips of the external 12 Vdc emergency power cable to any appropriate source of 12 Vdc power, being careful to observe proper polarity. The alligator clips are color coded to indicate which is the positive connector (red) and which is the negative connector (black).

(3) Resume operation of the transmitter in the same manner as when it was connected to its own source of 12 Vdc power.

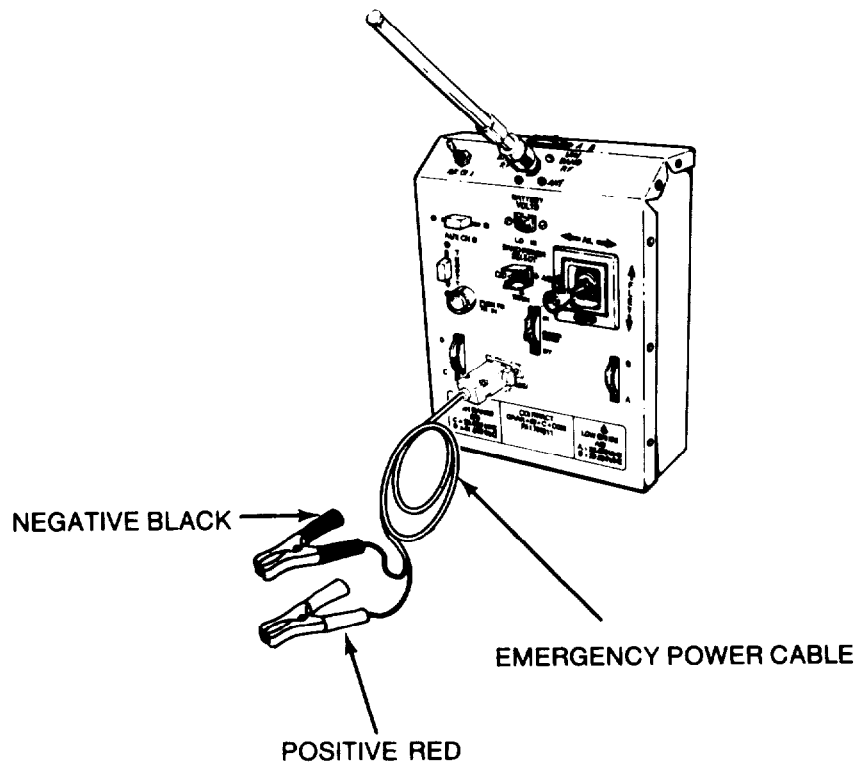

MS619646

Figure 2-37. External 12 Vdc emergency power cable operation of the transmitter.

CHAPTER 3 OPERATOR MAINTENANCE

Section I. INTRODUCTION

3-1. GENERAL.

This chapter contains information and instructions for performing assembly and maintenance procedures.

3-2. REPAIR PARTS,

Repair parts are listed in appendix D of this manual. All of the items contained in the field support kit are either part of the aircraft kit, or the support equipment.

Section II. SERVICE UPON RECEIPT

3-3. GENERAL.

This section contains procedures to be used by personnel upon receiving aerial target, transmitter, support equipment, and field support kits.

3-4. CHECKING UNPACKED EQUIPMENT.

- a. Inspect the equipment for damage incurred during shipment. If the equipment has been damaged, report the damage on DD Form 6, Packaging Improvement Report.
- b. Check the equipment against the packing slip to see if the shipment is complete. Report all discrepancies in accordance with the instructions of DA PAM 738-750.
- c. Check to see whether the equipment has been modified.

3-5. UNPACK GSE KIT.

- a. Open container and remove containerized GSE/FOB
- b. Remove accessory equipment.
- c. Verify contents per appendix D.

3-6. UNPACK AIRCRAFT KIT/FQM-117 B-1

NOTE

Only the top fuselage in each kit has the receiver and the servo/battery modules shipped in their respective cavities.

- a. Open the container from the top, remove the cardboard retainers and all the wing and fuselage sections by lifting the entire assembly from the box. If one wing or fuselage is needed bend the cardboard retainers aside and remove as needed.
- b. Remove the sub kit container.
- c. Remove cardboard forms from wing and fuselage sections. Verify contents per appendix D.

3-7. UNPACK AIRCRAFT KIT/FQM-117 C-1.

- a. Open the container from the end and remove the three kit boxes and the sub kit container.
- b. Open the kit and sub kit boxes. Verify contents per appendix D.

3-8. UNPACK TRANSMITTER KIT.

- a. Open container and remove two transmitter containers.
- b. Open each container and verify contents per appendix D.

3-9. ASSEMBLY PROCEDURES FOR THE FQM-117 B-1.

- a. Obtain the items in table 3-1, aircraft kit FQM-117 B-1. (For item identification, see figure 3-1.)
- b. Inspect the components for damage. Repair or reject as appropriate.

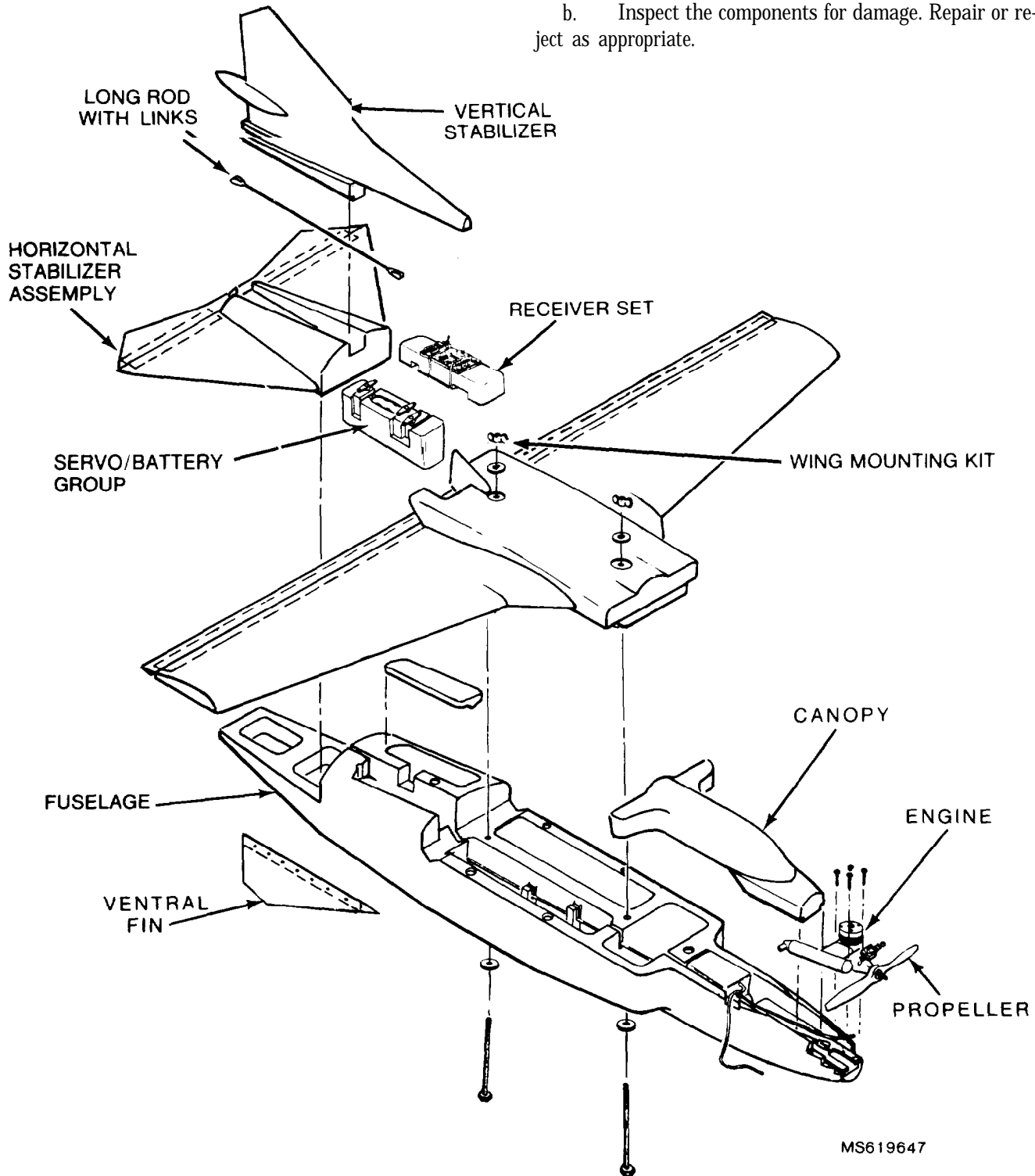

Figure 3-1. Aircraft/FQM-117 B-1 in exploded view.

Table 3-1. Materials Required for FQM-117 B-1 Assembly

Item	Quantity
Wing	1
Fuselage (with throttle pushrod assembly installed)	1
Receiver (installed in fuselage)	1
#64 Rubber Band	2
Small Foam Latex	1
Modified Receiver Mounting Plug	1
Servo/Battery Group (installed in fuselage)	1
Servo With Arm	3
Battery Pack	1
Foam Servo Mounting Plug	1
Long Rod with Links (taped to fuselage)	1
Vertical Fin	1
Horizontal Stabilizer	1
Canopy	1
#64 Rubber Band	2
Receiver Dust Cover	1
Epoxy	
Mixing Sticks	
Mixing Cups	
Ventral Fin	1
Wing Hold Down Bolt	2
Wing Bolt Washer	4
Wing Nut	2
Aluminum Foil Sheet	1
Short Rod With Links	2
Fuel Tank With Tubing	1
Engine With Glow Plug	1
Muffler	1
Engine Mount Screws	4
Muffler Screws	2
Muffler Extension	1
Wooden Prop	1

CAUTION

When utilizing epoxy to attach components, apply only to mating surfaces.

NOTE

Epoxy can be removed from the skin surface before or after it sets. In areas where hair is present, it is desirable to remove epoxy before it sets. Before it sets, remove by using soap, water and a cloth. After it sets, remove by peeling.

Epoxy mixing instructions are on the epoxy containers.

e. Perform the assembly procedures for the FQM-117B-1 as follows:

NOTE

Receiver and servo/battery group are shipped already installed in the fuselage. Do not remove.

(1) Place fuselage on a work table or flat surface.

(2) Install fuel tank. (See fig. 3-2.) Place the fuel tank in the cavity behind the engine mounting plate. Do not force it down into the cavity. Route the pressure line through the slot provided in the side of the fuselage opposite the throttle pushrod.

(3) Attach canopy. (see fig. 3-2.) Insert canopy on top of fuselage. Secure with four rubber bands. Ensure that it does not pinch the lines.

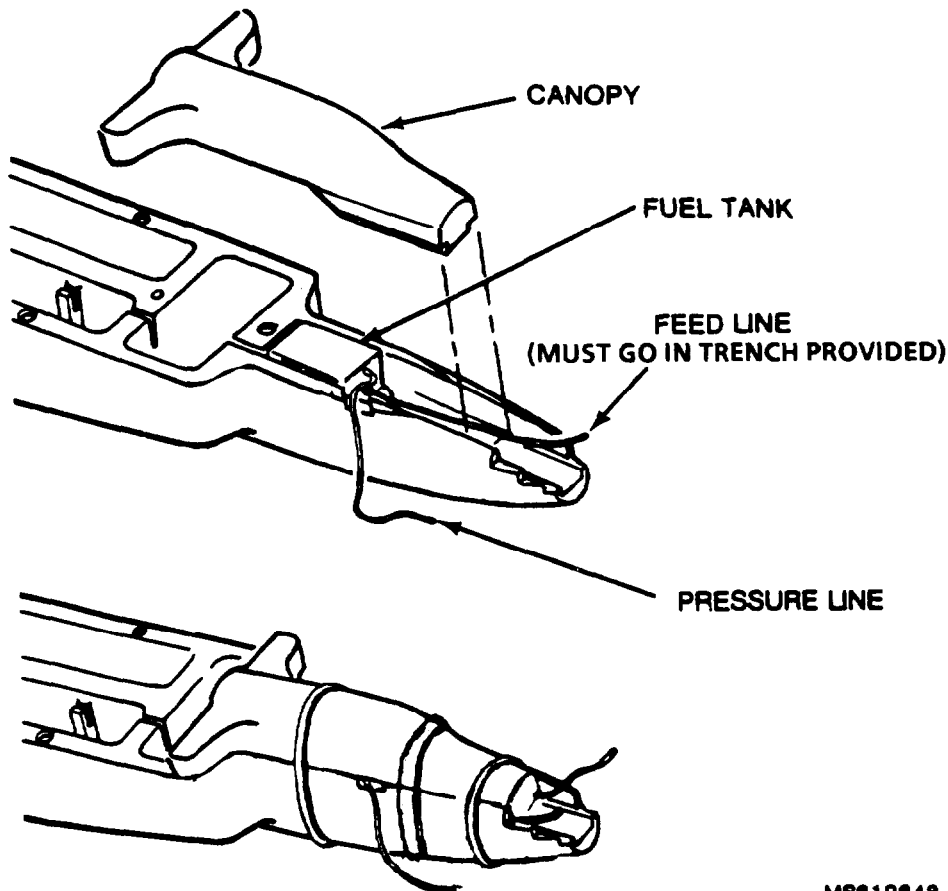

MS619648

Figure 3-2. Fuel tank and canopy installation.

(4) Attach horizontal stabilizer/elevator. (See fig. 3-3.) Epoxy horizontal stabilizer/elevator to the rear of the fuselage using approximately 1 ounce of epoxy. Ensure that the horizontal stabilizer is fully seated in the fuselage cavities.

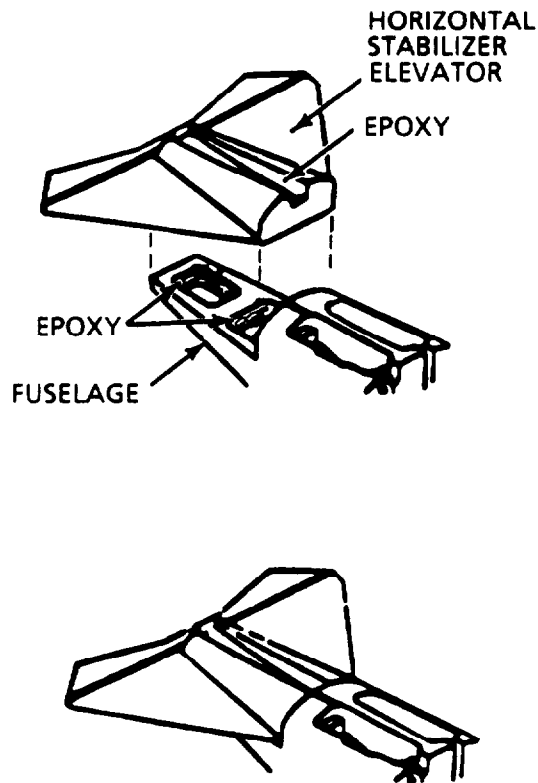

MS619649

Figure 3-3. Horizontal stabilizer/elevator installation.

(5) Attach vertical stabilizer. (See fig. 3-4.) Epoxy vertical stabilizer to top-rear of fuselage assembly using approximately 1 ounce of epoxy. Hold in position until epoxy has set. Ensure that no epoxy gets into the elevator pushrod slot.

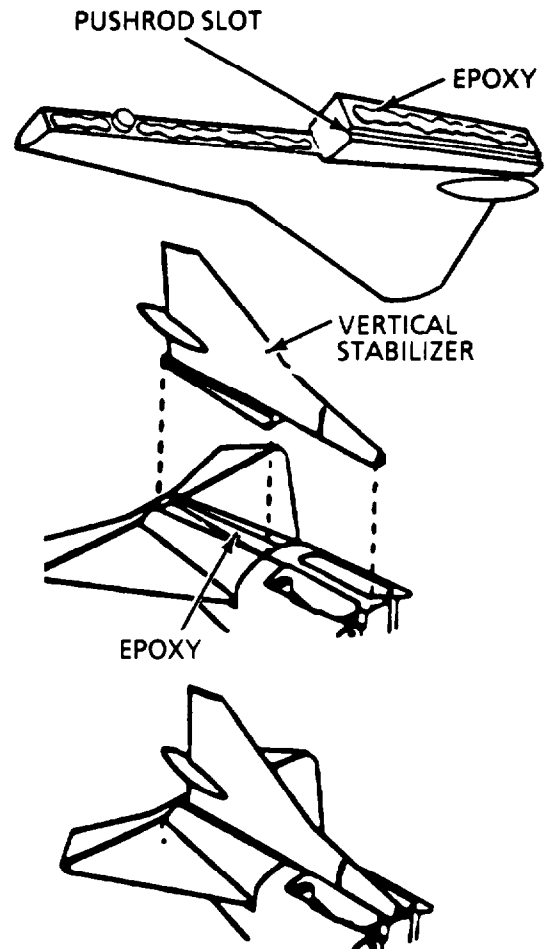

MS619650

Figure 3-4. Vertical stabilizer installation.

(6) Install engine. (See fig. 3-5.) Attach engine to mounting plate installed in the nose of the fuselage using four self tapping screws. Tighten all screws "wrist tight" (approximately 20-25 in-lbs). Ensure all screws on engine are tight prior to installation). Do not install muffler at this time.

NOTE

Before mounting engine, fill mounting screw holes with epoxy (item 2, app E).

CAUTION

The servos and the battery, as well as the receiver are shipped pre-mounted to foam mounting plugs. These mounting plugs are to be used for installing these components. Do not remove them from these mounting plugs. They protect the components from damage during flight.

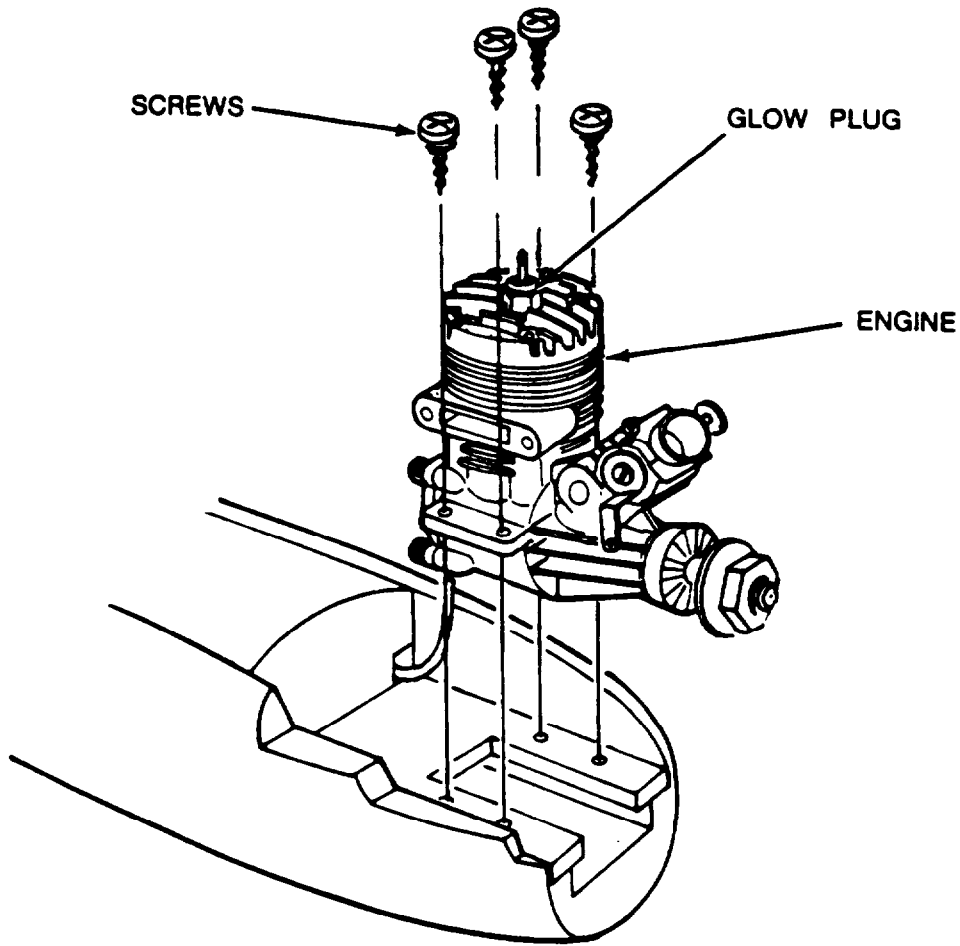

Figure 3-5. Engine installation.

NOTE

In all connections to the receiver, the black (or negative) lead is always to the outside edge of the receiver.

The receiver antenna is already plugged into the receiver and threaded through the strain relief hole.

(7) Connect the servo/battery group to the receiver. (See fig. 3-6) Feed the wire from the servo and battery pack individually through the opening between the flight control compartment and the receiver compartment. Be aware that the

receiver module and the servo/battery module are already installed in the aircraft.

(a) Connect the elevator servo connector to the receiver elevator plug.

(b) Connect the aileron servo connector to the receiver aileron channel plug.

(c) Connect the throttle servo connector to the receiver throttle channel plug.

(d) Connect the battery connector to the receiver power plug.

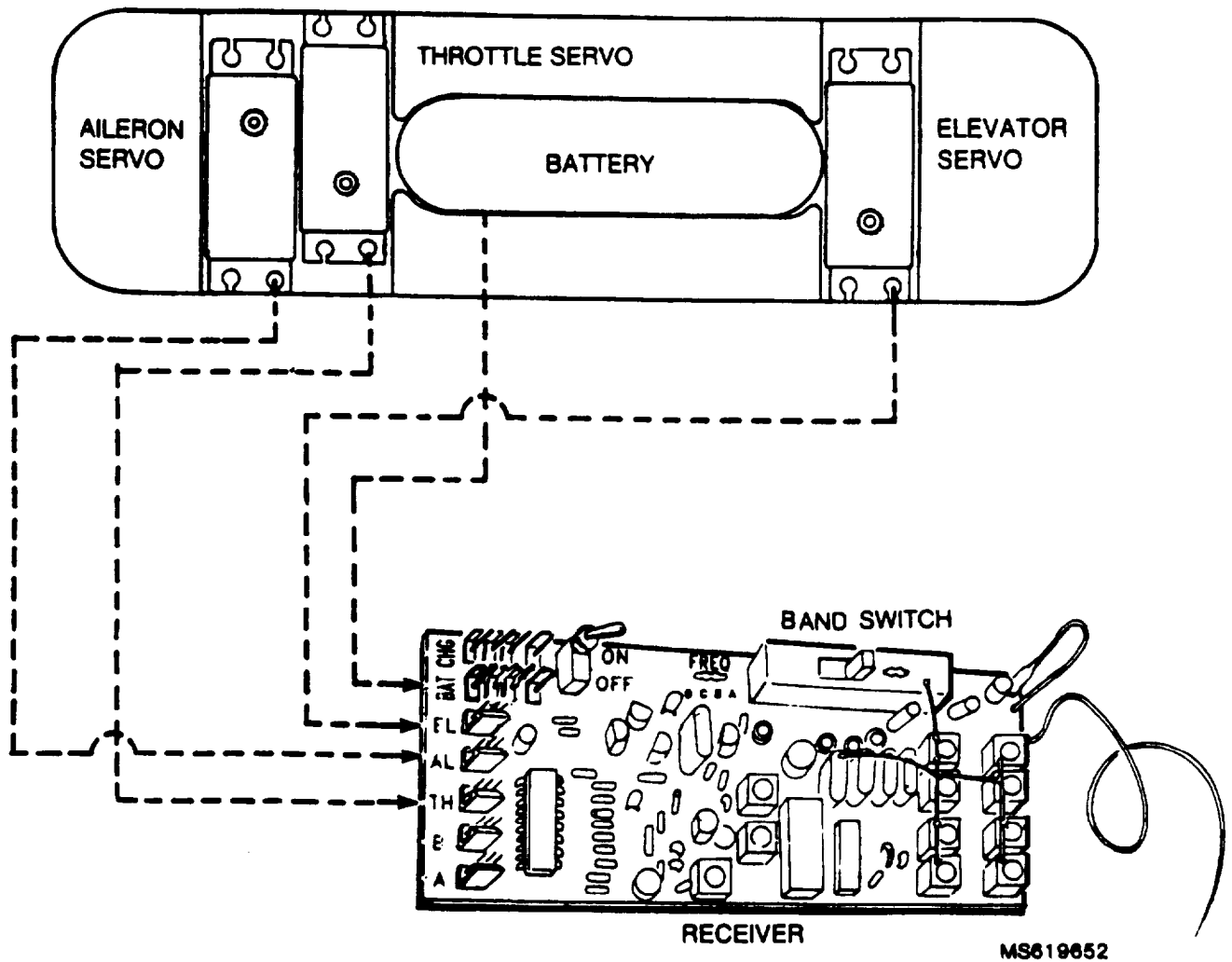
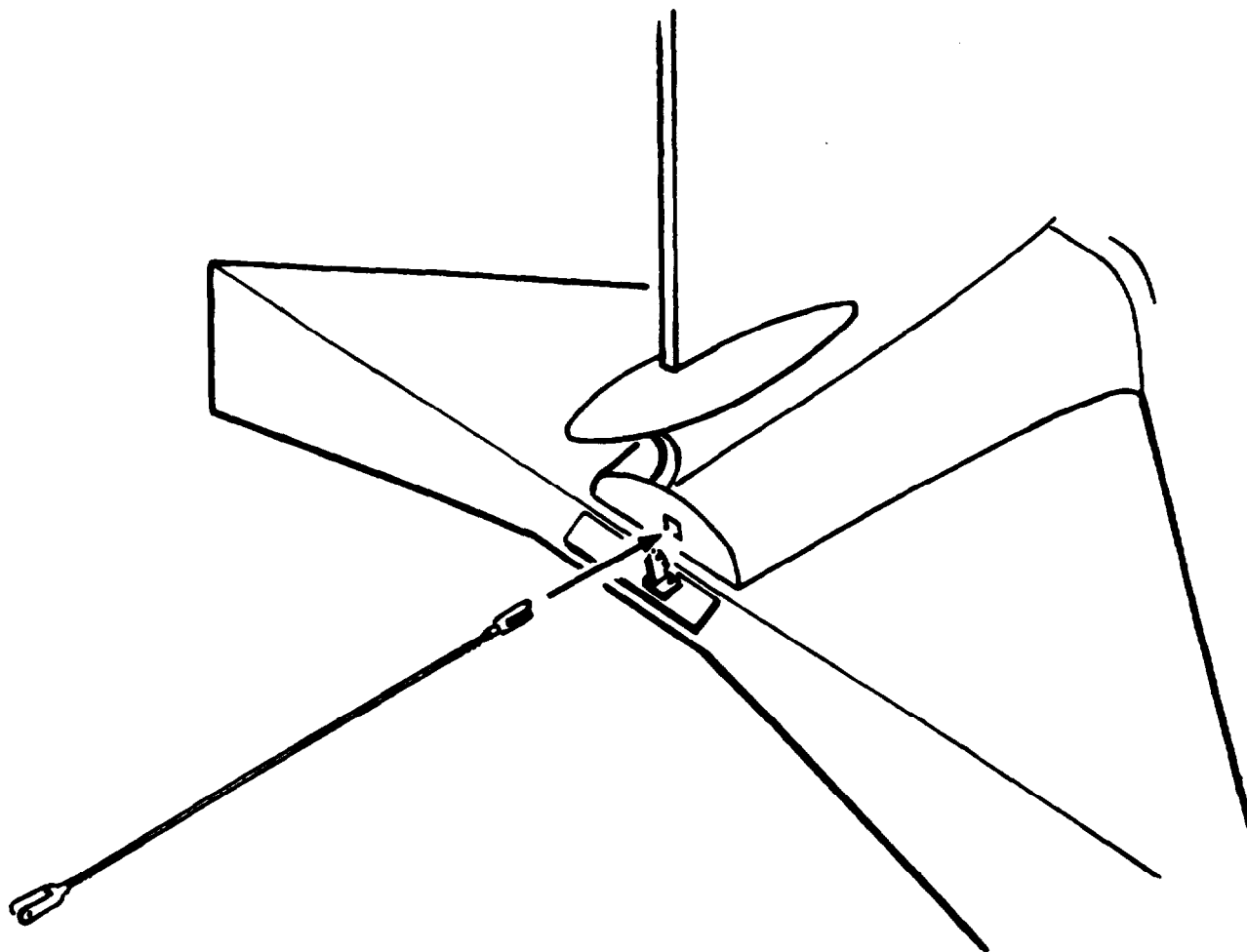

Figure 3-6. Servo/battery group to receiver interconnection diagram.

(8) Install pushrod. (See fig. 3-7.) Insert long pushrod (with snap links attached) into the slot at

the aft end of the fuselage. Attach pushrod into proper control hole selection (see fig. 2-7).



M881953

Figure 3-7. Pushrod installation.

(9) Route antenna. (See fig. 3-8.) Cut three slots in the vertical stabilizer, utilizing the saw from the GSE, as shown in figure 3-8. These slots do not have to be cut very deep into the vertical stabilizer; a 1/2 inch deep slot is sufficient.

Insert the antenna into the slots cut in the vertical stabilizer, in the manner shown in figure 3-8, leaving a small amount of slack in the receiver compartment.

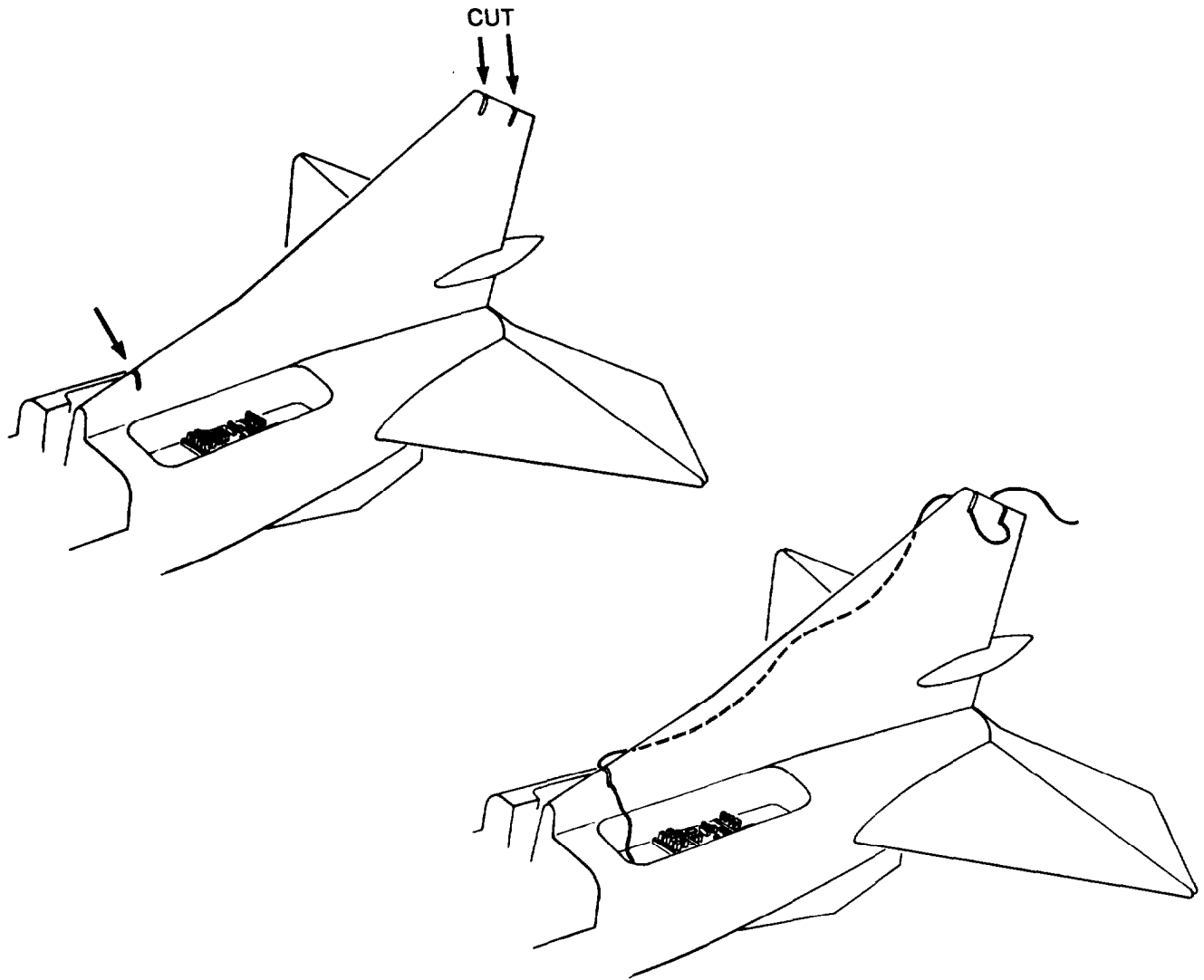

MS619654

Figure 3-8. Antenna routing.

(10) Place aluminum foil ball in fuselage. (See fig. 3-9.) Loosely crumple one sheet of aluminum foil into a ball approximately the size of a baseball. Place the ball of foil in the forward payload bay of the fuselage.

(11) Install wing assembly. (See fig. 3-9.) Ensure

screw holes in wing and fuselage are free from foam. Place wing on fuselage. Put a washer on each wing mounting bolt and insert through the bottom of the fuselage. Place a washer on each protruding bolt shank before installing wing nut. Tighten wing mounting bolts "finger-tight" (approximately 10-12 in/lbs).

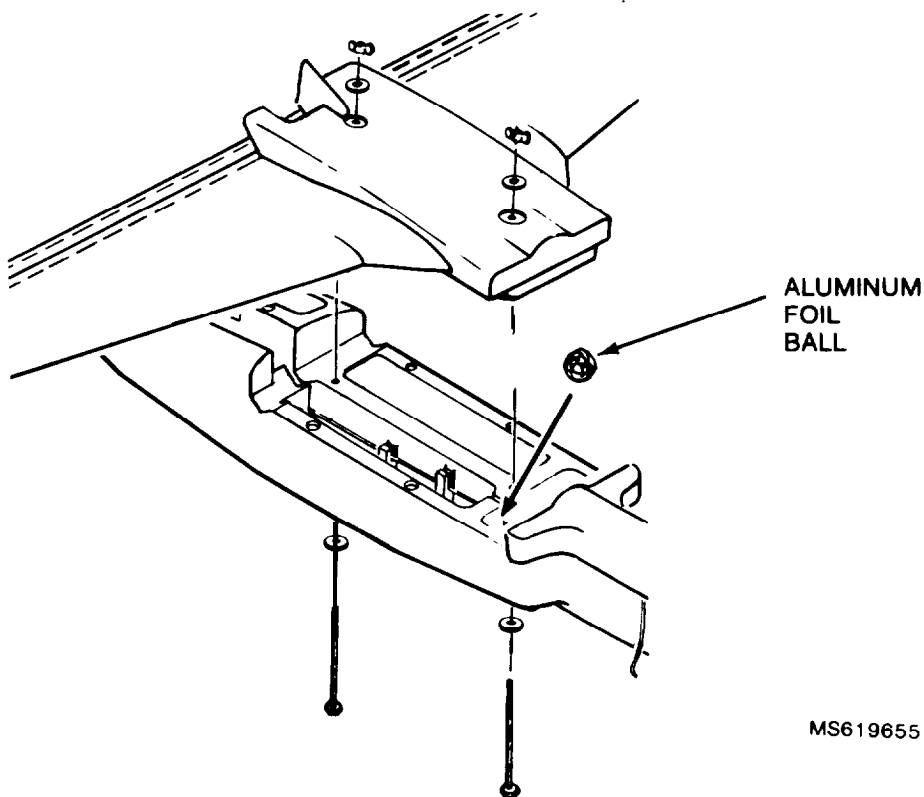
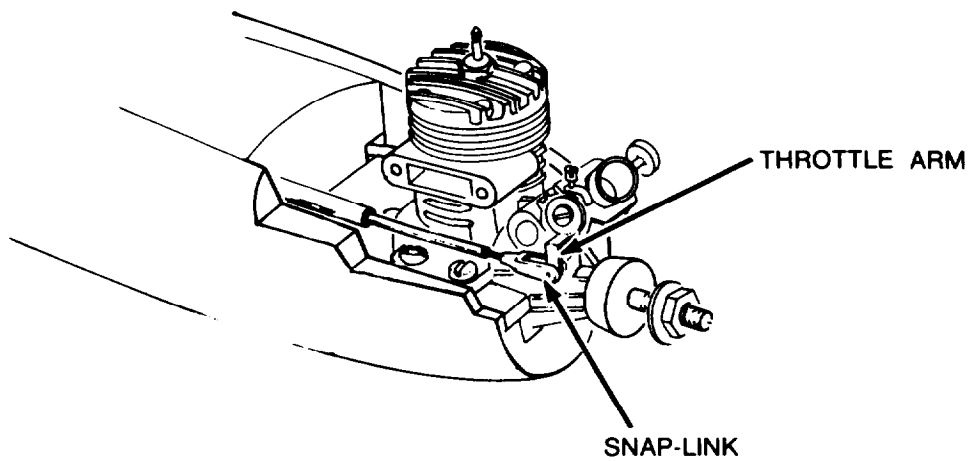

Figure 3-9. Wing assembly installation.

(12) Connect control snap links.

(a) Connect throttle pushrod snap link to engine throttle. (See fig. 3-10.)



MS619656

Figure 3-10. Snap link attachment to throttle.

(b) Connect elevator and throttle snap links to servo arms. (See fig. 3-11.)

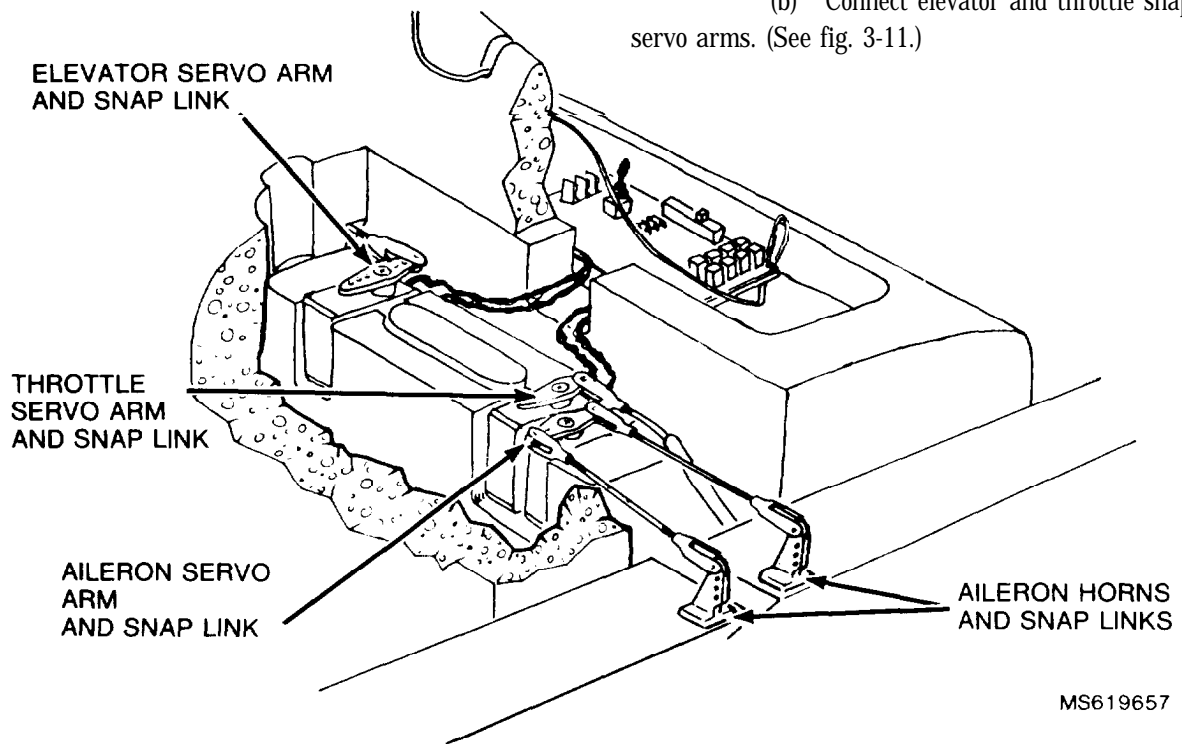

MS619657

Figure 3-11. Snap link attachment to servo arms and aileron horns.

(c) Connect elevator snap links to elevator control horn. (See fig. 3-12.)

(13) Install short pushrods. (See fig. 3-11.) Connect the short pushrod snap link to the aileron horns and the aileron servo arms.

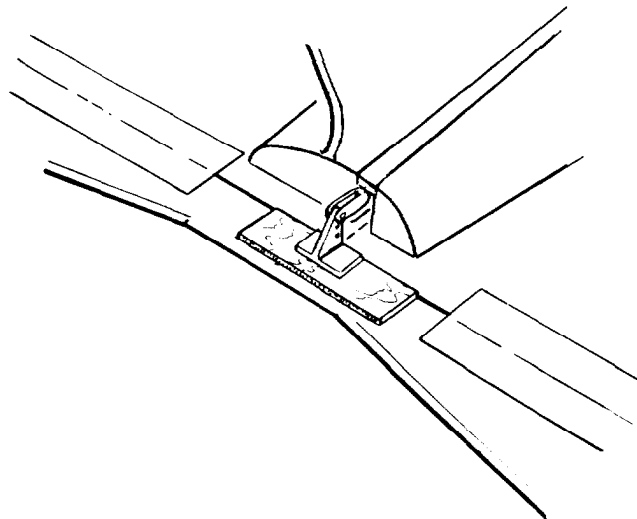

MS619658

Figure 3-12. Snap link attachment to elevator horn.

(14) Install ventral fin. (See fig. 3-13.) Epoxy ventral fin in slot on bottom of fuselage using approximately 1/2 ounce of epoxy.

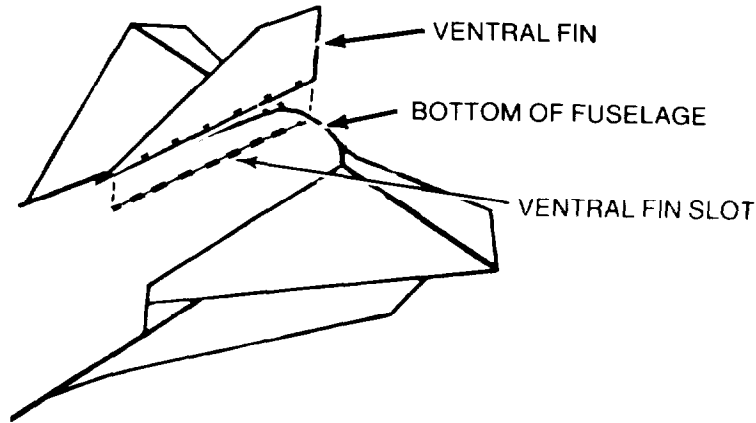

MS619659

Figure 3-13. Ventral fin installation.

(15) Attach propeller. (See fig. 3-14.) Attach propeller to engine assembly using 4-way wrench. Tighten nut "wrist tight" (approximately 20-25 in/lbs). Rounded face of propeller faces away from engine. This is normally the side with the propeller trade name or size printed on it.

(16) Install muffler. (see fig. 3-14.) Attach muffler using two screws, and the muffler extension provided. Tighten the screw "wrist tight" (approximately 20-25 in/lbs).

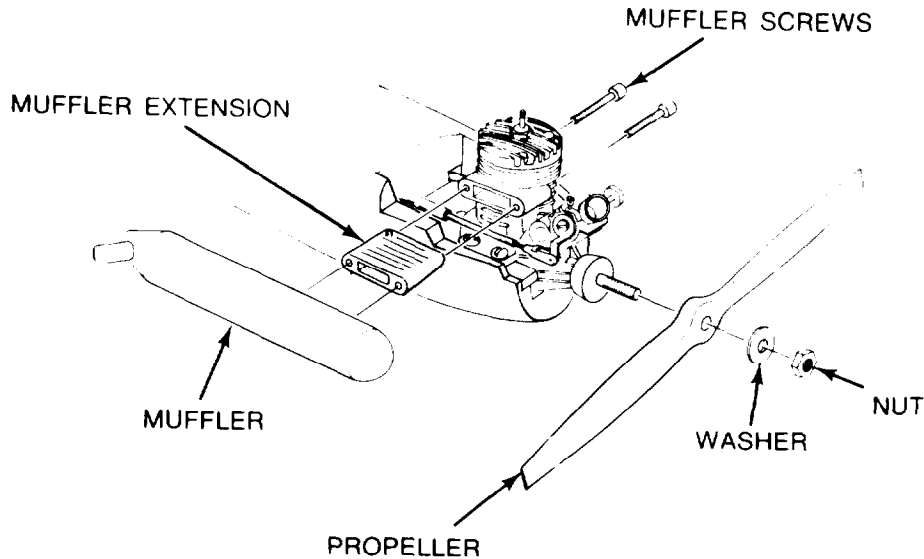

MS619660

Figure 3-14. Propeller and muffler installation.

(17) Connect feed and pressure lines. (See fig. 3-15.) Connect the fuel lead to the carburetor nipple. Connect the pressure line to the muffler extension nipple.

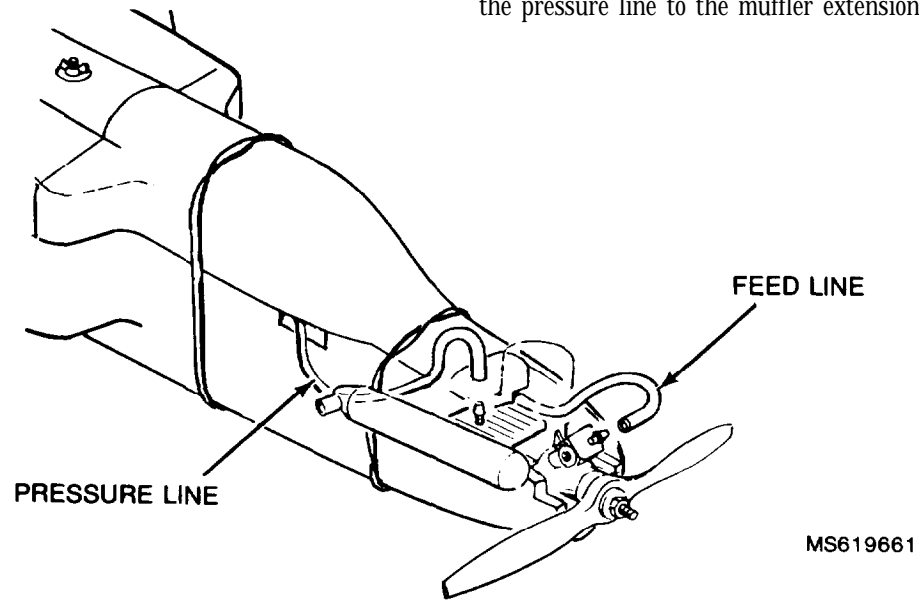

Figure 3-15. Feed and pressure tine connection.

(18) Install dust cover. (See fig. 3-16.) Install dust cover over receiver. Ensure that there is enough slack in the receiver antenna to prevent it from being strained.

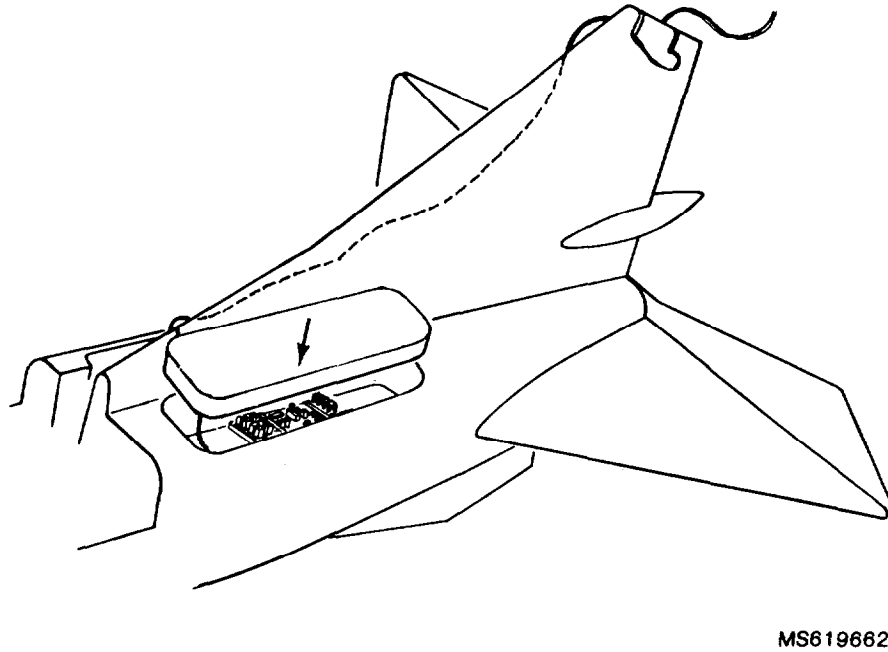
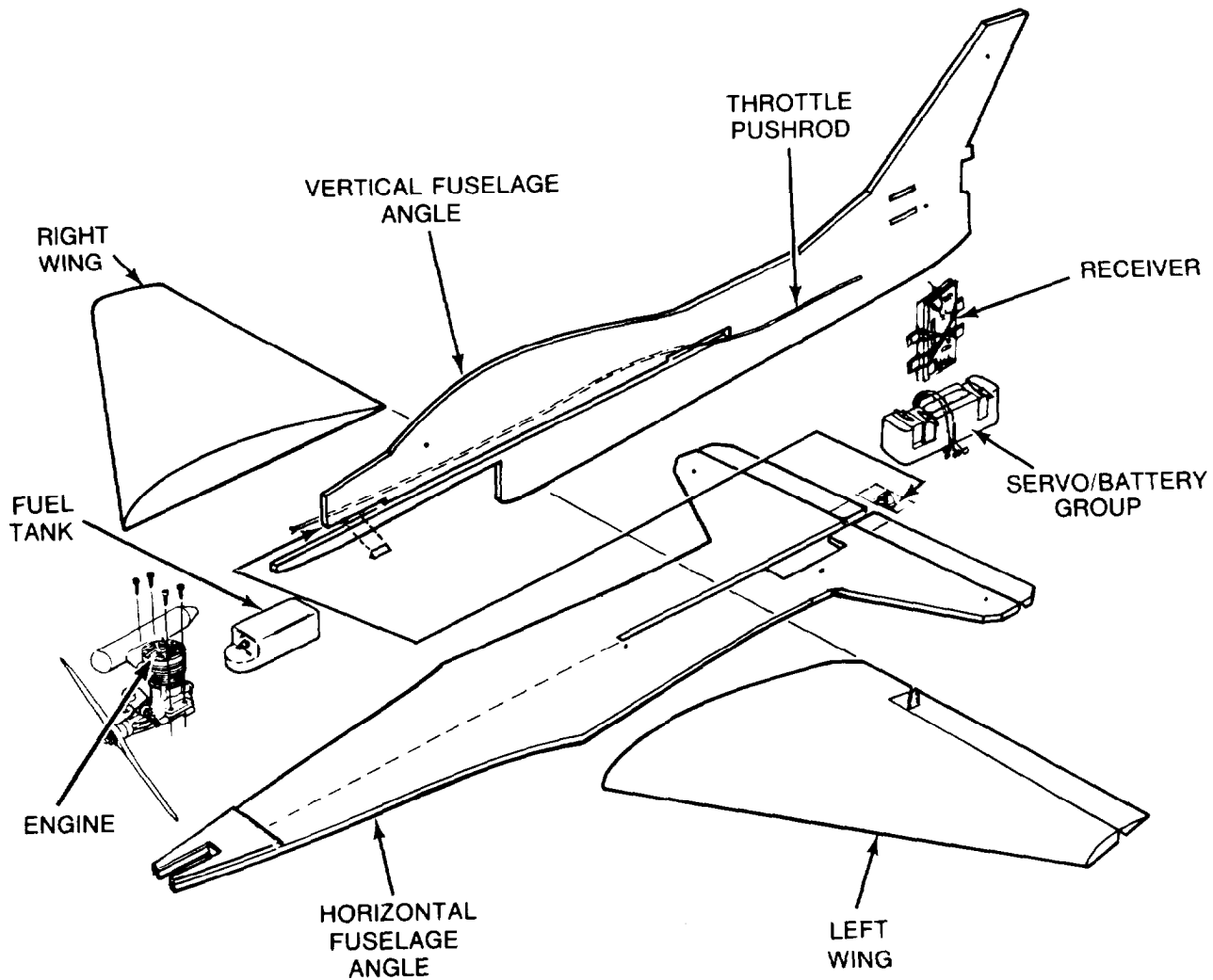

Figure 3-16. Dust cover installation.

3-10. ASSEMBLY PROCEDURES FOR THE FQM-117 C-1

b. Inspect the components for damage. Repair or reject as appropriate.

a. Obtain the items in table 3-2. aircraft kit/FQM-117 C-1. (For item identification, see figure 3-17.)



MS619663

Figure 3-17. Aircraft/FQM-117 C-1 in exploded view.

Table 3-2. Materials Required for FQM-117C-1 Assembly

Item	Quantity
Right Foam Wing	1
Left Foam Wing	1
Vertical Fuselage Angle	1
Horizontal Fuselage Angle	1
Throttle Pushrod With Links	1
Engine With Glow Plug	1
Muffler	1
Engine Mount Screws	4
Muffler Screws	2
Muffler Extension	1
Medium Rod With Links	1
Short Rod With Links	1
Elevator Joiner	1
Wooden Props	1
Epoxy	
Mixing Sticks	
Mixing Cups	
#64 Rubber Band	
Dowel	4
Fuel Tank With Tubing	1
Reciever	1
Small Foam Latex Pad	1
Servo/Battery Group	1
Servo With Arms	3
Battery Pack	1
Foam Servo Mounting Plug	1

CAUTION

When utilizing epoxy to attach components, apply only to mating surfaces.

NOTE

Epoxy can be removed from skin surface before or after it sets. In areas where hair is present, it is desirable to remove epoxy before it sets. Before it sets, remove by using soap, water and a cloth. After it sets, remove by peeling.

Epoxy mixing instructions are on the epoxy containers.

c. Perform the assembly procedures for the FQM-117 C-1 as follows:

(1) Place horizontal fuselage on a work table or flat surface. Horizontal fuselage is right side up when the wing trailing edge reference mark is visible.

(2) Attach fuselage halves together. (See fig. 3-18.) Slide vertical fuselage onto horizontal fuselage. Using approximately 1 ounce of epoxy attach the two halves together by pushing the two halves slightly apart and putting epoxy on the mating surfaces. Pushing the fuselage halves any further apart than necessary (about 1/2-3/4 of an inch) will result in breakage. Ensure that no epoxy gets into the slot for the throttle pushrod. Using approximately 1/4 ounce of epoxy, glue the two gussets to the front vertical fuselage.

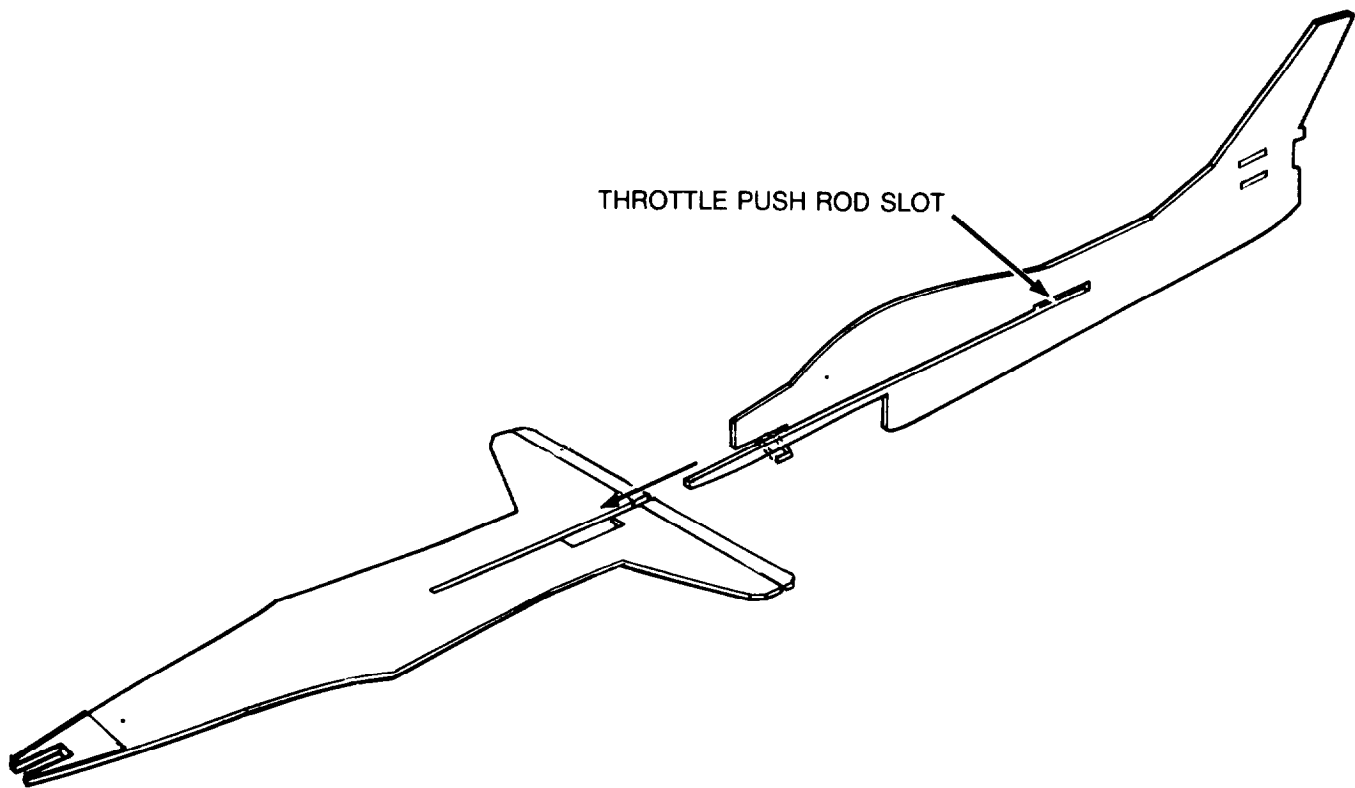

MS619664

Figure 3-18. Vertical and horizontal fuselage joining.

(3) Install engine. (See fig. 3-19) Attach engine to mounting plate installed in the nose of the fuselage using four self tapping screws. Tighten all screws "wrist tight" (approximately 20-25 in/lbs). Ensure all screws on engine are tight prior to installation.

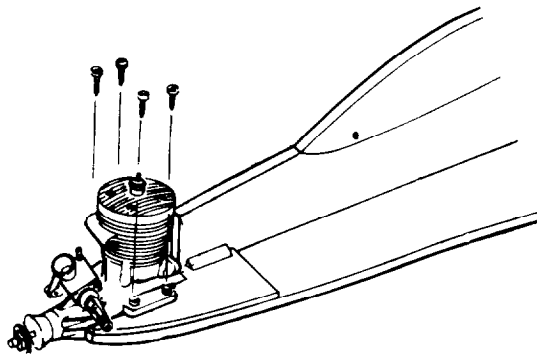

MS619665

Figure 3-19. Engine installation.

(4) Install servo/battery module. (See fig. 3-20.) Ensure that the two servos in the module face forward. Install servo/battery module into cutout in the horizontal fuselage. Ensure that the module is fully seated in the cutout. Thread a rubber band into the holes in the fuselage. Secure the rubber band with a dowel in each end.

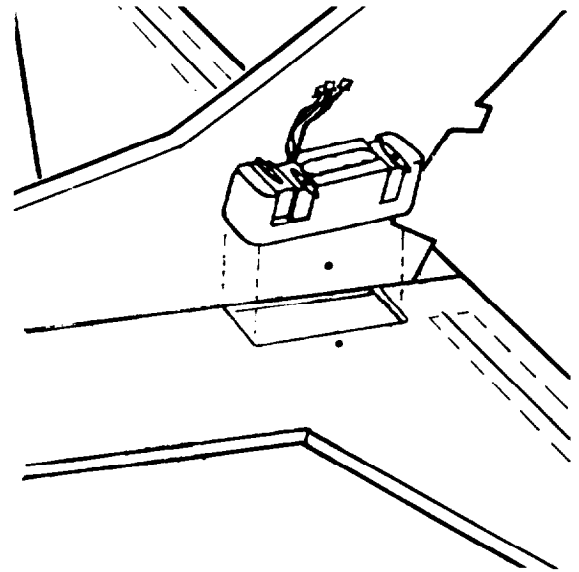

MS619666

Figure 3-20. Servo/battery module installation.

CAUTION

The servos and the battery are shipped pre-mounted to a foam mounting plug. This mounting plug is to be used for installing these components. Do not remove them from this mounting plug. It protects the components from damage during flight.

(5) Install throttle pushrod and sleeve. (See fig. 3-21.) Slide throttle pushrod assembly through slot in the vertical fuselage. Connect one end of the throttle arm to the

engine. Connect the other end to the throttle servo arm. Using approximately 1\8 ounce of epoxy, tack glue each end of the outer throttle sleeve.

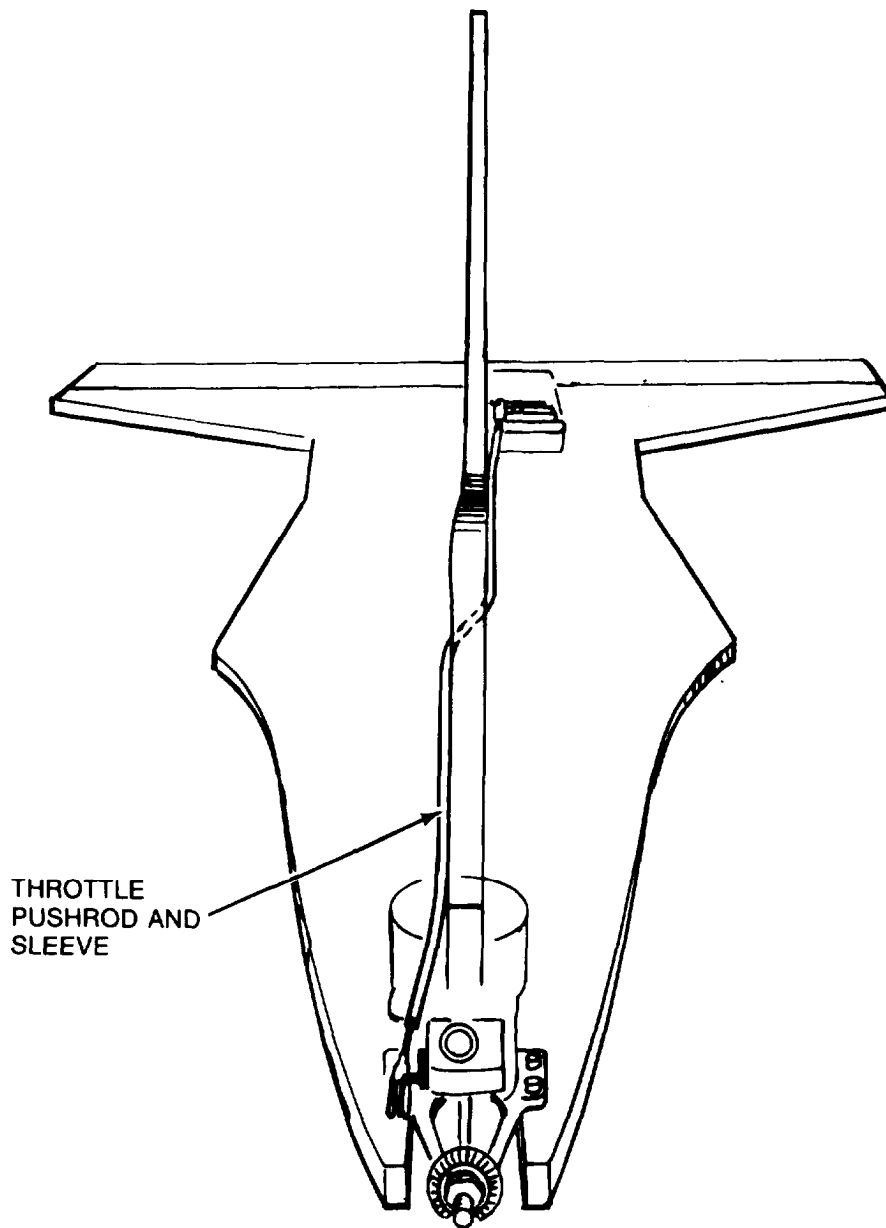

MS619667

Figure 3-21. Throttle pushrod and sleeve installation.

(6) Install wing halves. (See fig. 3-22.) Trial fit each wing half onto the fuselage. Mark along the bottom of each wing half the amount it overlaps the horizontal fuselage. Using approximately one ounce of epoxy, coat the bottom of the wing (up to the intersection line) and the wing root.

Position the wing half on the horizontal fuselage and line the trailing edge up with the reference line. Ensure that the throttle pushrod is in the groove along the bottom edge of the wing root. Hold until dry. Repeat the procedure for the other half of the wing.

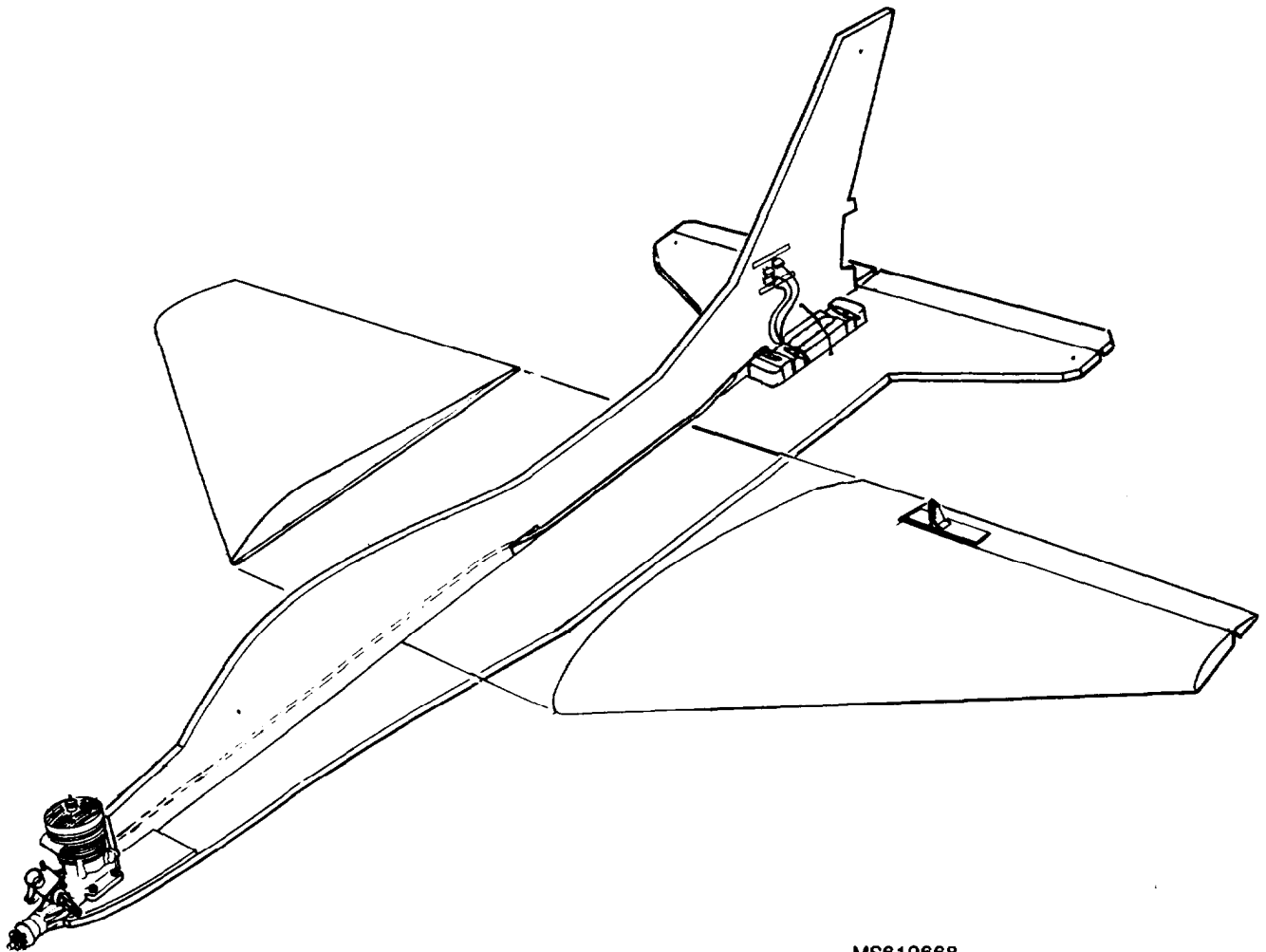
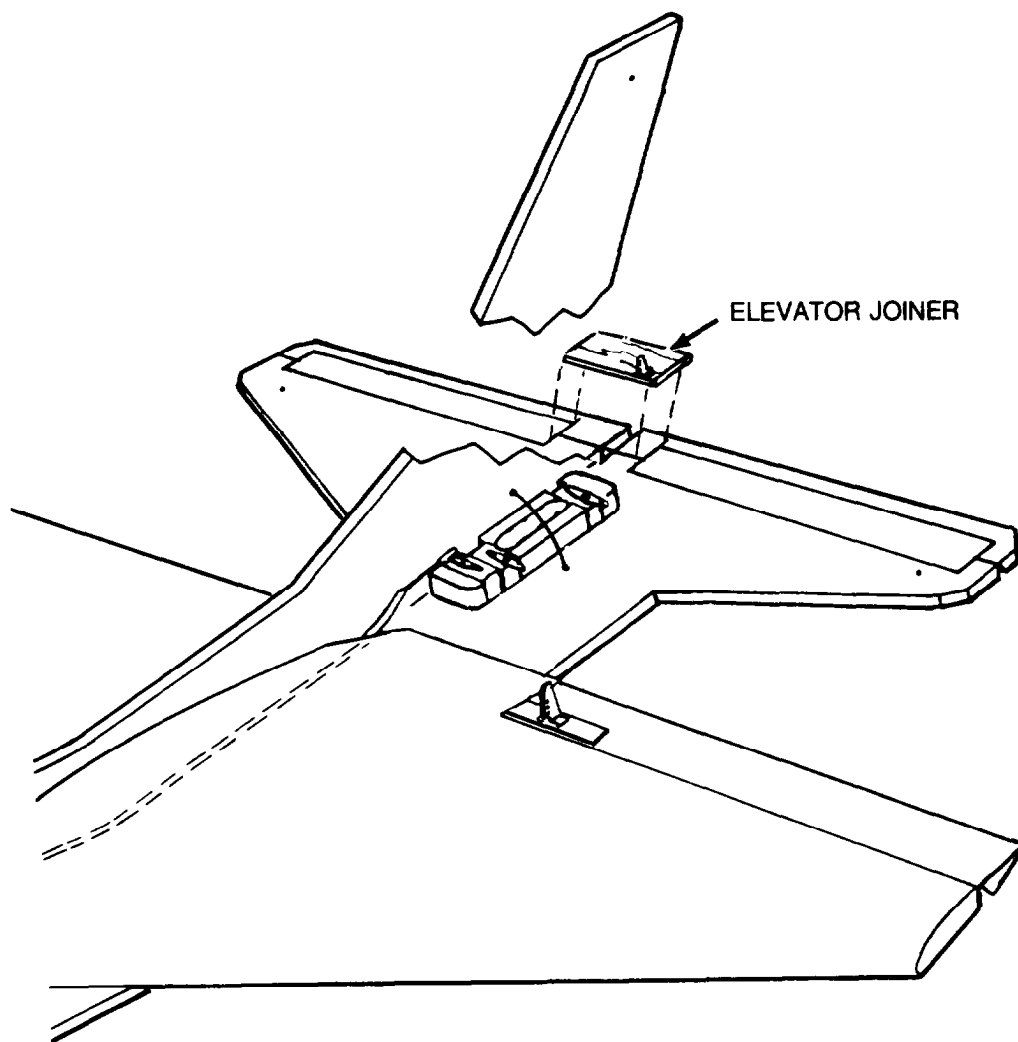

Figure 3-22. Wing installation.

(7) Install elevator joiner. (See fig. 3-23.) Using approximately 1/8 ounce of epoxy, coat the bottom of the elevator joiner. Position the joiner so that it lines up

with the reference lines on the elevator and so that the elevator horn is directly behind the elevator servo and the holes in the horn line up with the hinge line.



MS619669

Figure 3-23. Elevator joiner installation.

(8) Install aileron pushrod. (See fig. 3-24.) Connect a medium pushrod snap link to the aileron servo arm and the snap link on the other end to the aileron horn.

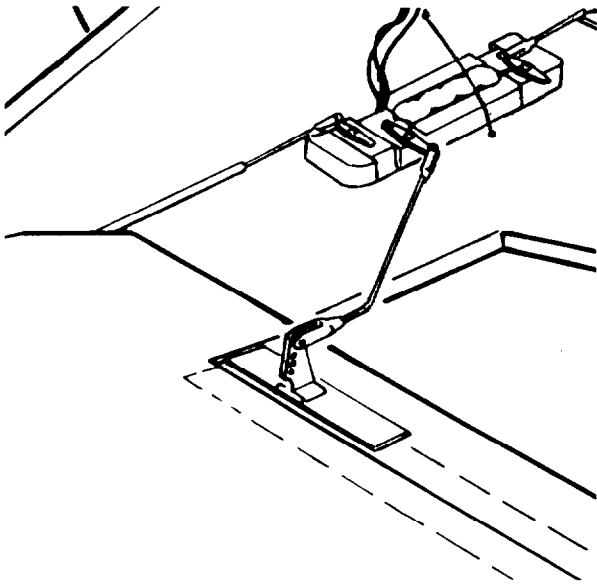

MS619670

Figure 3-24. Aileron pushrod installation.

(9) Install elevator pushrod. (See fig. 3-25.) Connect a short pushrod snap link to the elevator servo arm and the snap link on the other end to the elevator horn.

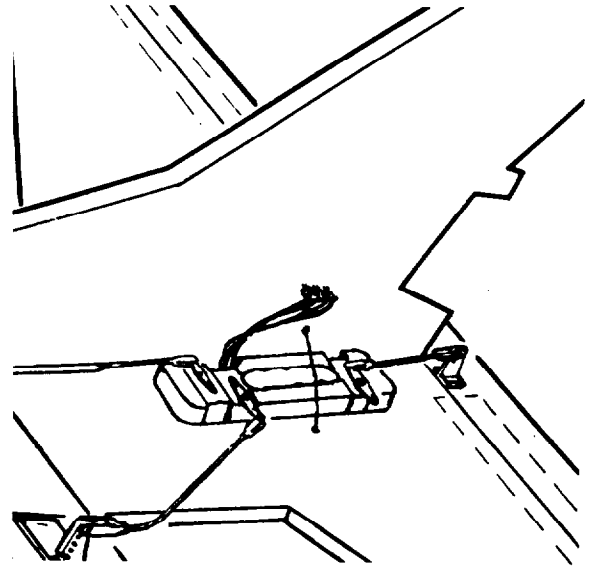

MS619671

Figure 3-25. Elevator pushrod installation.

(10) Install the receiver. (See fig. 3-26.) Lay the foam pad and the receiver perpendicular to the receiver hold down rails on the horizontal fuselage. Using two rubber bands

attach the receiver and pad to the rails. Ensure that the receiver is positioned so that the connector block is to the top of the fuselage.

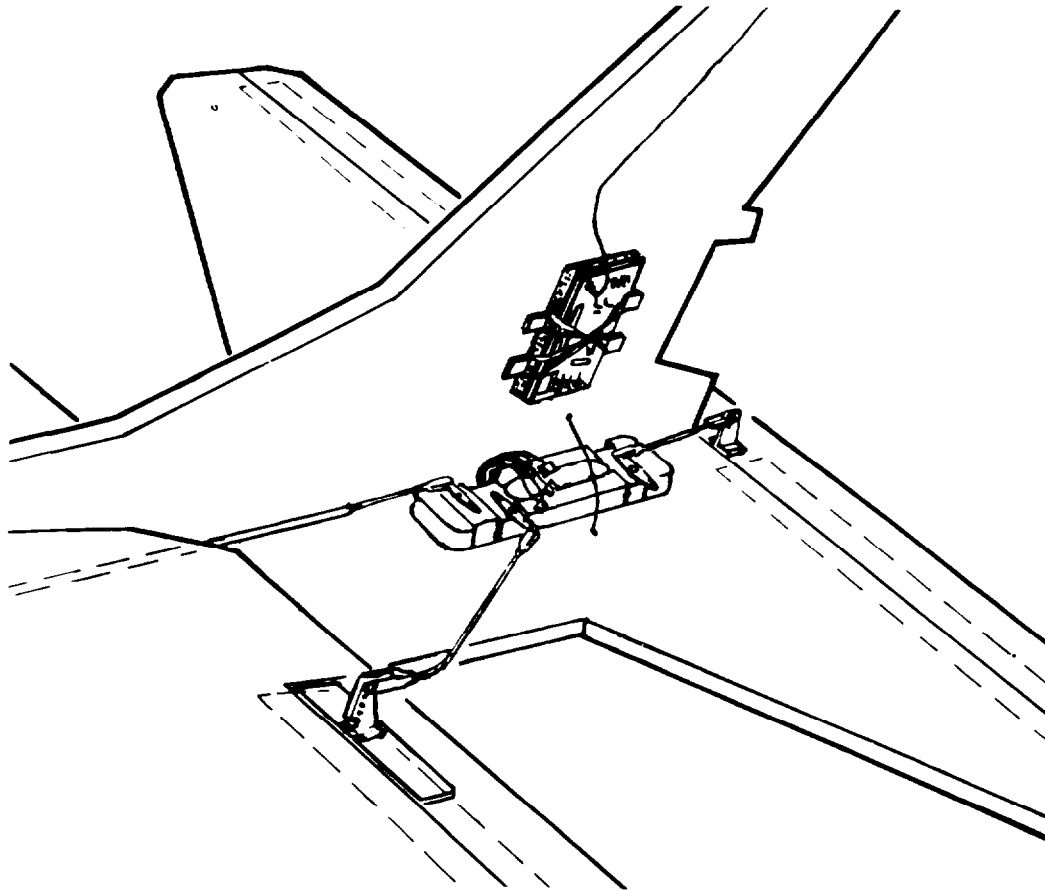

MS619672

Figure 3-26. Receiver installation.

(11) Install the fuel tank. (See fig. 3-27.) On the right hand side of the fuselage (when viewed from the rear), thread a rubber band through the holes in the vertical and horizontal fuselages. Secure the rubber band with a dowel in each

end. Slide the tank under the rubber band. Ensure that the nose of the tank is right up against the back edge of the engine hold down plate and the back of the tank is against the fuel tank back stop.

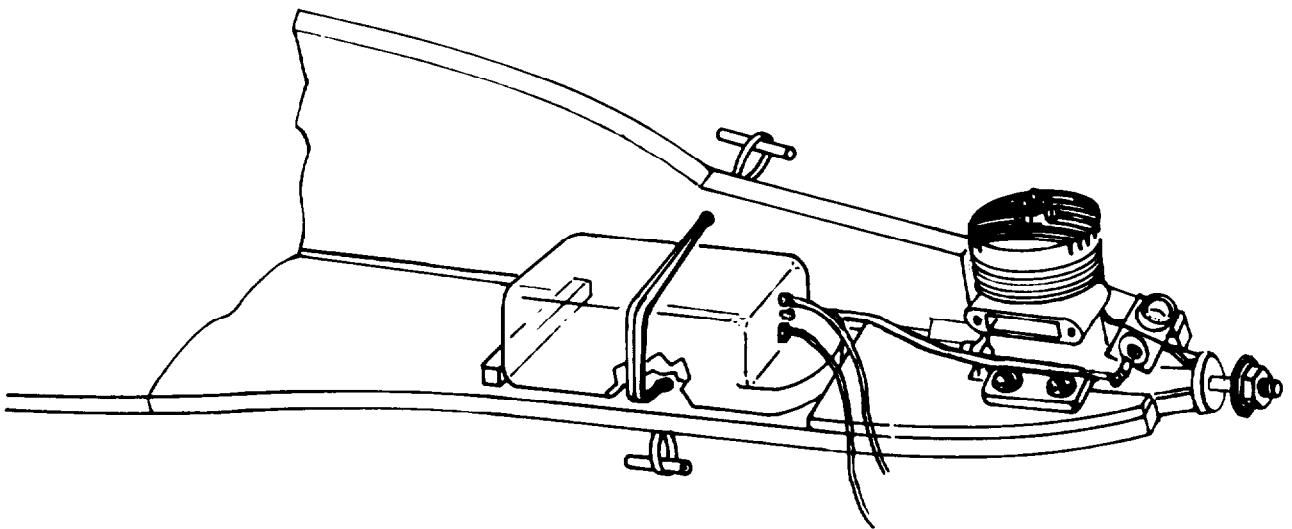

MS619673

Figure 3-27. Fuel tank installation.

NOTE

In all connections to the receiver, the black (or negative) lead is always to the outside of the receiver. The receiver antenna is already plugged into the receiver and threaded through the strain relief hole.

(12) Connect the servo/battery group to the receiver. (See fig. 3-6.)

(a) Connect the battery connector to the receiver power plug.

(b) Connect the elevator servo connector to the receiver elevator channel plug.

(c) Connect the aileron servo connector to the receiver aileron channel plug.

(d) Connect the throttle servo connector to the receiver throttle channel plug.

(13) Route antenna. (See fig. 3-28.) Cut two slots in the vertical stabilizer as shown. These slots do not have to be cut very deep into the vertical stabilizer; a 1/2 inch depth slot is sufficient. Insert the antenna into the slots cut in the vertical stabilizer in the manner shown, allowing for a small amount of slack.

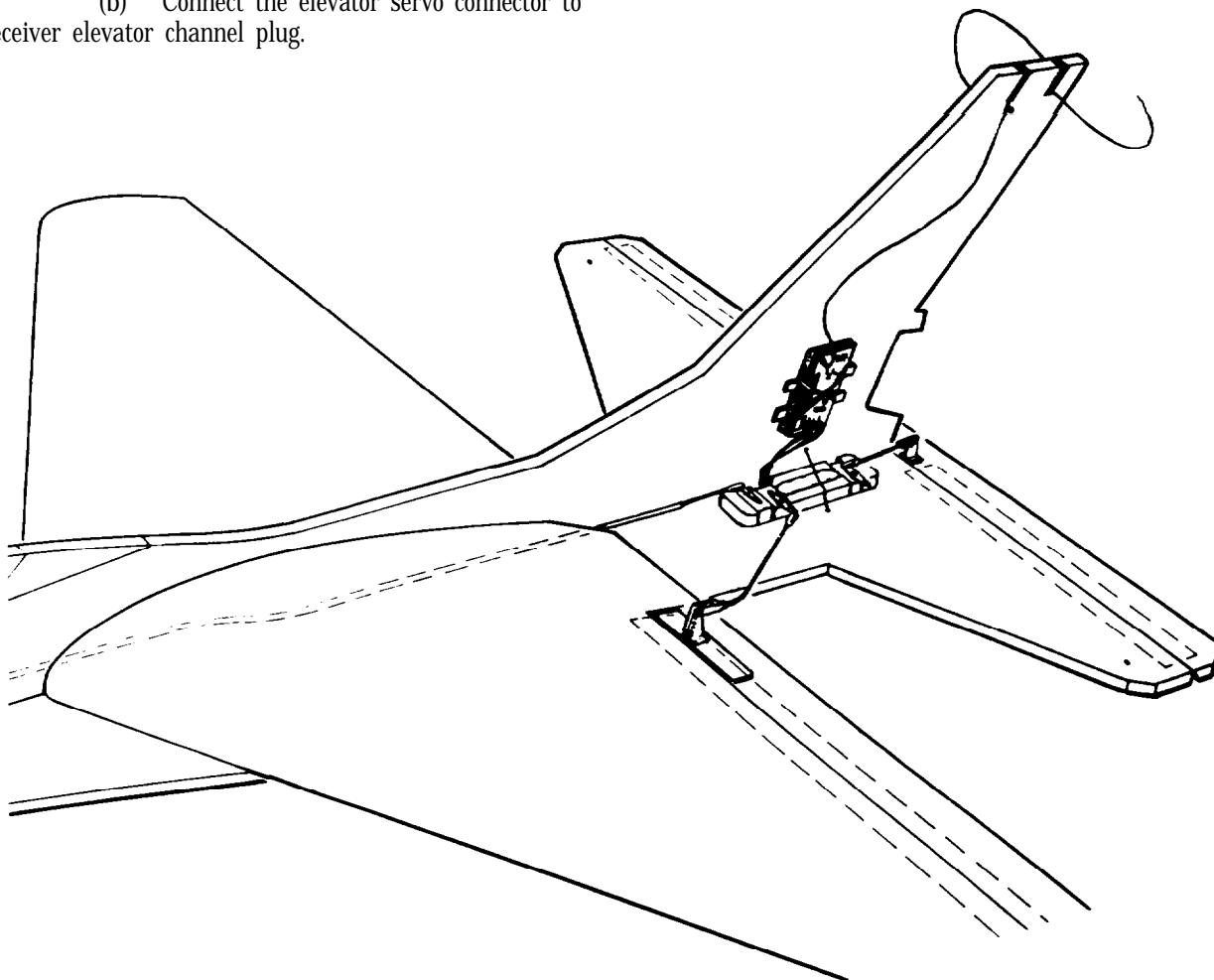

MS619674

Figure 3-28. Antenna routing.

(14) Attach propeller. (See fig. 3-14.) Attach propeller to engine assembly using a 4-way wrench. Tighten nut "wrist tight" (approximately 20-25 in/lbs). Rounded face of propeller facts away from engine. This is normally the side with the propeller trade name or size printed on it.

(15) Install muffler. (See fig. 3-14.) Attach muffler using two screws and the muffler extension provided. Tighten screws "wrist tight" (approximately 20-25 in/lbs).

(16) Connect feed and pressure lines. (See fig. 3-29.) Connect the fuel feed to the carburetor nipple. Connect the pressure line to the muffler extension nipple.

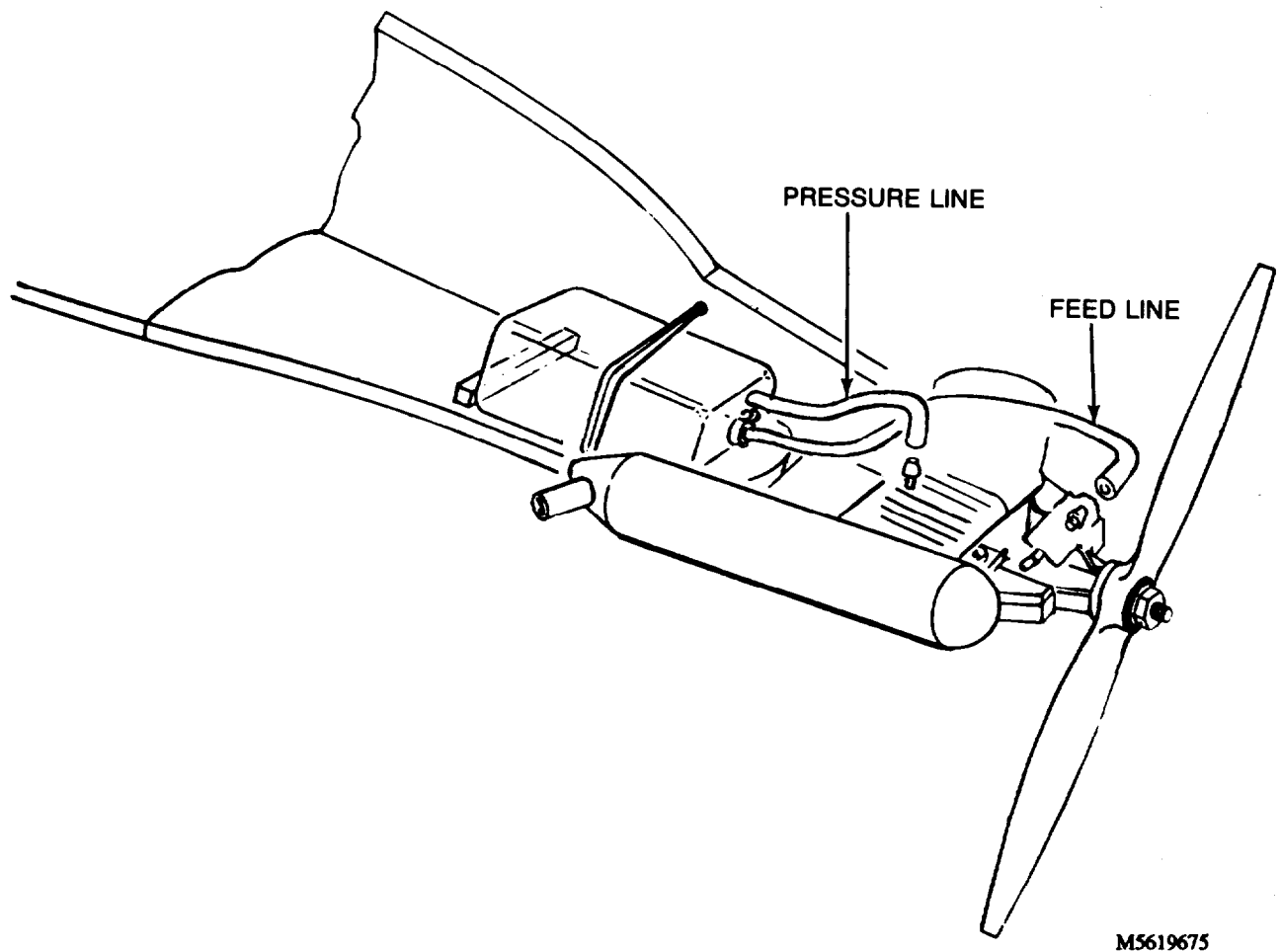

Figure 3-29. Feed and pressure line connection.

3-11. TRANSMITTER ASSEMBLY PROCEDURES.

a. Obtain the following items from the transmitter kit container: (Refer to figure 3-30 for identification.)

1. Transmitter
2. Antenna
3. Neck strap

b. Inspect the components for damage and repair or reject as appropriate.

CAUTION

Transmitter and receiver must be set to same channel to achieve operation.

- (1) Install the antenna. (Refer to figure 3-30 for location and proper orientation), tighten antenna sleeve "finger tight" (approximately 10-12 in/lbs).
- (2) Attach neck strap to neck strap eyelet.

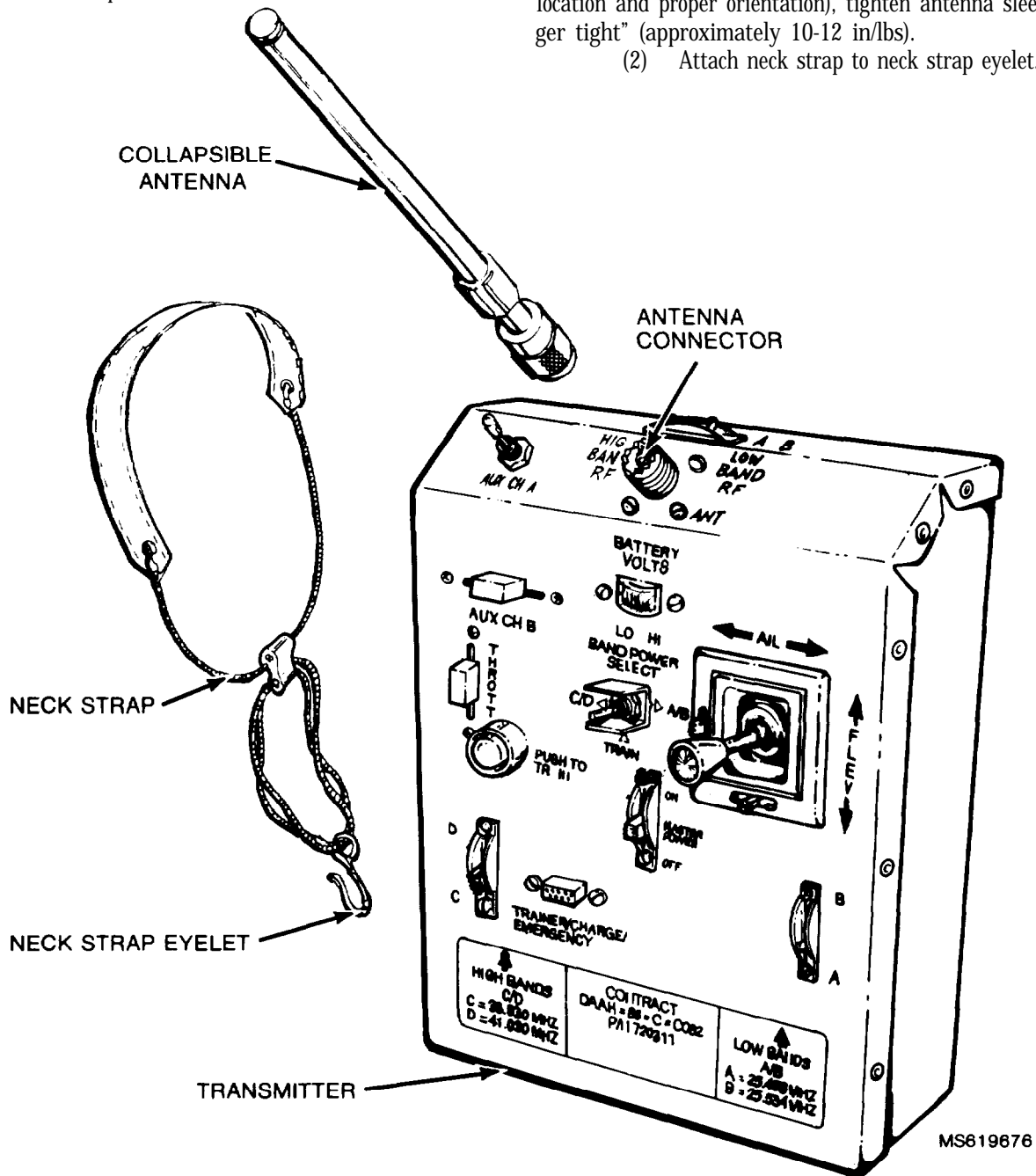

Figure 3-30. Transmitter assembly.

**3-12. GROUND SUPPORT EQUIPMENT (GSE)
KIT ASSEMBLY PROCEDURES.**

a. Obtain the following items, listed in Table 3-3, from the GSE kit container: (For item identification, see figure D-3.)

Table 3-3. Materials Required for GSE Assembly

Item	Quantity
GSE Master Charger Set	1
GSE Master Charger	1
GSE Field Box or Transmitter Charge Cables	5
Receiver Charge Cables/Short	4
Receiver Charge Cables/Medium	4
Receiver Charge Cables/Long	4
GSE Field Box Set	1
GSE Field Box	1
12 Volt Starter Battery (Installed)	1
12 Volt Fuel Pump with Tubing (Installed)	1
Fuel Can with Cap Fillings (Installed)	1
Power Panel (Installed)	1
12 Volt Starter	1
Glow Plug Clip	3
Emergency Power Cables	1
Transmitter Trainer Cord	1
DC Voltmeter	1
Tool Set	1
4-Way Prop Wrench	1
Large Phillips Screwdriver	1
Small Phillips Screwdriver	1
Small Standard Screwdriver	1
Foam Saw	1
Needle Nose Pliers	1
4-40 Allen Wrench	1
6-32 Allen Wrench	1
Hemostat	4

b. Inspect the components for damage. Repair or reject as appropriate.

c. Perform the assembly procedures for the ground support equipment as follows:

(1) Place the following items in the GSE/field box storage drawer and compartment:

- Glow plug clips
- Tool set
- Multimeter
- Transmitter trainer cord
- Emergency power cable

(2) Connect starter power leads. (See fig. 2-13.) Connect starter power leads to GSE power panel. Place starter in rectangular receptacle.

(3) Check nicad battery voltage level using the GSE multimeter. (See fig. 2-30.) Charge the battery if voltage level is below 12 volts. (For charging procedures, see paragraph 2-22.)

Section III. TROUBLESHOOTING PROCEDURES

3-13. INTRODUCTION.

Table 3-4 lists the common malfunctions which may be found during the operation or maintenance of the FQM-117 B-1 and FQM-117 C-1 or its components. Perform the tests, inspections and corrective actions in the order listed.

3-14. GENERAL.

This manual cannot list all malfunctions that may occur, nor all tests or inspections and corrective actions. If a malfunction is not listed or is not corrected by listed corrective actions, notify your supervisor.

Table 3-4. Troubleshooting

MALFUNCTION	TEST OR INSPECTION	CORRECTIVE ACTION
1. ENGINE WILL NOT START (OR HARD TO START)		
Step 1.	Check fuel. Bad fuel may have moisture, din, or sand in it.	Refuel with clean, moisture free fuel.
Step 2.	Check to see if carburetor is flooded.	Clear flooded carburetor by turning aerial target on its side with carburetor air intake pointed downward.
Step 3.	Check carburetor to see if fuel is present when primed. Check return lines for holes or foreign matter.	Replace or clean return lines.
Step 4.	Check needle valve adjustment. A wrong needle valve adjustment lets the engine fire, but dies immediately.	Adjust needle valve ccw so that mixture is rich.
Step 5.	Check glow plug. It should be tight, seal should not leak, and should read approximately 3 on power panel ammeter.	Replace glow plug.
Step 6.	Check engine for loose or missing screws.	Tighten or replace screws.
2. ENGINE STOPS IN FLIGHT.		
Step 1.	Check for fuel starvation. Small holes and cracks in fuel lines leak air during flight because of vibration.	Replace defective fuel lines.

Table 3-4. Troubleshooting - Cont.

MALFUNCTION	TEST OR INSPECTION	CORRECTIVE ACTION
	Step 2.	Check for blown glow plug. It should read approximately 3 on ammeter on powerpanel. Replace glow plug.
	Step 3.	Inspect fuel tank for residue. Check vent tube and fuel take-up line in tank for obstructions. Clear residue from tank and tubes.
	Step 4.	Inspect engine to determine if it is worn out, leaking around seals or damaged. Replace defective engine.

3. ENGINE WILL NOT IDLE.

- Step 1. Check fuel. Bad fuel may have moisture, dirt, or sand.
Replace with clean, moisture free fuel.
- Step 2. Check needle valve adjustment. It may be too lean.
Adjust needle valve ccw so that the mixture is rich.

WARNING

When performing step 3, ensure that the glow plug clip is not attached to glow plug. Injuries could result if engine should start during this step.

- Step 3. Disconnect glow plug clip. Check that engine parts are tight and not leaking compression. Check for air bubbles by pouring fuel on the engine as the propeller is turned over by hand.
Tighten head bolts and glow plug.

4. FLIGHT CONTROLS AND/OR THROTTLE DO NOT RESPOND TO COMMANDS.

CAUTION

Do not force control rods or pushrods to move. Damage to servo gears can result.

- Step 1. Check to see if both transmitter and receiver power switches are set to ON.
Set power switches on transmitter and receiver/servo group to ON.
- Step 2. Check to see if the transmitter band power select switch is set to the proper band and not to train.
Set band power select switch to the proper band.
- Step 3. Check to see if the transmitter RF band switch is set to the proper band.
Set RF band switch to the proper band.
- Step 4. Check to see if transmitter frequency matches receiver frequency.
Set transmitter channel select switch to match receiver channel.
- Step 5. Check transmitter receiver and servo/battery group battery voltage levels.
Charge battery if voltage is below 12 volts per paragraph 2-22. Charge receiver and servo/battery group battery if voltage is below 4.8 volts, per paragraph 2-23.
- Step 6. Check to see if transmitter or receiver and servo/battery group is operative. Operate transmitter on a known operational receiver and servo/battery group. If response is not obtained, transmitter is inoperative. If response is obtained, receiver and servo/battery group is inoperative.
Replace inoperative transmitter or receiver and servo/battery group as appropriate.

Table 3-4. Troubleshooting - Cont.

MALFUNCTION

TEST OR INSPECTION

CORRECTIVE ACTION

5. ENGINE WILL NOT FIRE.

- Step 1. Check glow plug. Remove glow plug and place it in end of glow plug power clip. Observe that glow plug glows brightly.
 Replace glow plug if defective.
- Step 2. Check carburetor for presence of fuel. Remove needle valve and purge with fuel by connecting fuel pump tube directly to fuel inlet on carburetor and pumping fuel directly through carburetor. Reinstall needle valve in carburetor.
 Replace engine, if it still will not fire.

SECTION IV. MAINTENANCE PROCEDURES

3-15. INTRODUCTION.

This section provides instructions to maintain the FQM-117 B-1 and FQM-117 C-1. Table 3-5 lists maintenance procedures to perform to maintain the aircraft.

Initial Setup

General Safety: Keep flammable solvents away from open flame.

Equipment Required: Tools, spare parts, epoxy, fuel, clean lint-free damp cloth or brush, and light oil.

Table 3-5. FQM-117 B-1 and FQM-117 C-1 Maintenance Procedures

Task	Item	Action
1. Inspection	a. Airframe	(1) Visually inspect for damage beyond safe or serviceable limits, i.e., broken wing, damaged aileron, broken propeller. (2) Visually inspect for proper assembly. (3) Check for loose parts. (4) Check for wear and corrosion.
	b. Fuel tank	Check for punctures.
	c. Fuel tubing, aileron, elevator hinges and rubber bands	Check flexible materials for hardness, cracks, or breaks.
	d. Caution plates, data, markings and primed matter	Check for legibility.
2. Checks/adjustments, alignment	Throttle pushrod assembly	(1) Adjust the connector ends of the pushrod so that the carburetor barrel operates from fully opened to fully closed when controlled from the transmitter.

NOTE

This adjustment ensures that the engine can be stopped during flight by moving the throttle control to minimum.

Table 3-5. QM-117B-1 and FQM-117C-1 Maintenance Procedures - Cont.

Task	Item	Action
3. Removal, replacement, repair, and patching	a. Target items initially installed on airframe	(2) Set transmitter power switch to ON. (3) Set receiver and servo/battery group switch to ON. (4) Operate transmitter throttle from maximum to minimum while observing carburetor barrel through carburetor air intake. The barrel should be fully opened when throttle control is at maximum and closed prior to minimum position. (5) Turn threaded rod to make the adjustment. Space rod equally between the snap link and pushrod. Use the epoxy provided in the field support kit to repair breaks or cracks in airframe. Use minimum amount of epoxy possible to effect the repair.

NOTE

The throttle pushrod assembly consists of the sleeve that is installed into the fuselage, pushrod, and snap links which connect to the carburetor and throttle servo arms. Adjustment of the pushrod length controls the degree of movement of the throttle lever.

b. Throttle pushrod assembly	(1) Disconnect the pushrod assembly from the carburetor throttle and throttle servo arm. (2) Remove a snap link from one end and slide assembly out. (3) Insert new throttle pushrod assembly into sleeve. Attach a snap link to end. (4) Reconnect snap links to carburetor throttle and throttle servo arm. (5) Adjust throttle pushrod assembly. (See paragraph 2-10.b.)
c. Muffler	(1) Disconnect the muffler fuel tank tube. Do not close off the vent hole to the fuel tank. (2) Remove the 2 long screws that attach the muffler and the muffler extension to the engine. Remove muffler. (3) Install the new muffler and muffler extension using the 2 long screws and reconnect the fuel pressure line.
d. Receiver and servo/battery group	See paragraph 3-7 for replacement.
e. Airframe	Use minimal amount of epoxy to repair breaks and cracks.

Table 3-5. QM-117B-1 and FQM-117C-1 Maintenance Procedures - Cont.

Task	Item	Action
4. Cleaning	f. Fuel tubing and rubber bands a. Carburetor and engine parts.	Use extra fuel tubing and rubber bands provided in the field support kit to replace worn, brittle, or cracked material.

WARNING

The fuel is flammable. Use only in well ventilated area. Extinguish all flames and do not light matches or smoke while handling fuel.

CAUTION

Do not turn the propeller if any dirt is visible in the carburetor air intake or exhaust port. Turning the propeller, even slowly, can cause damage and pull dirt into internal parts making cleaning more difficult.

- (1) Clean carburetor and engine parts with fuel.

WARNING

During and immediately after operating, the engine and muffler are hot. Do not touch hot surfaces; it will result in a burn.

When performing the next step, the engine and the glow plug must be cool. Injury could result if the engine should start during this step.

- (2) Add fuel to engine and rotate propeller to determine if grit is present, the propeller shaft is bent, or if any binding has resulted.
- (3) If grit is felt in engine, replace engine.
- (4) Check propeller. Replace if damaged.

CAUTION

Do not attempt to start the engine if the shaft is bent or binding.

Table 3-5. QM-117B-1 and FQM-117C-1 Maintenance Procedures - Cont.

Task	Item	Action
	b. Target	(5) Start the engine for a test run if no binding or grit is felt.
<p>CAUTION</p> <p>Use only clear water. Do not use solvents such as lacquer thinner around plastic or polystyrene parts.</p> <p>Do not paint any part of the airframe. Paint will damage the polystyrene foam material.</p>		
		<p>(1) Remove dust and loose dirt from all exterior surfaces with a clean, lint-free cloth or brush.</p> <p>(2) Remove fuel and ground-in dirt with a cloth dampened (not wet) with water or alcohol (item 7, app. C).</p> <p>(3) Lightly coat engine parts with a light oil as a rust preventive, following cleaning of the engine with water.</p>

3-16. PREPARATION FOR STORAGE.

When the engine will be stored for more than 1 week, perform the following:

- a. Remove the glow plug from the engine.

- b. Add 5-10 drops of general purpose lubrication oil to glow plug access hole.

- c. Rotate the propeller several times to distribute the oil throughout the engine.

- d. Install glow plug in engine.

CHAPTER 4
AUXILIARY EQUIPMENT

Section I. GENERAL

4-1. PURPOSE.

- a. The flight stabilization unit (FSU) is designed for use as a training aide. It is used to stabilize the plane in flight.
- b. The field support kit is comprised of spare parts to support the aerial target.

4-2. LOCATION AND DESCRIPTION OF FSU COMPONENTS.

The location and description of the flight stabilization unit (FSU) components are illustrated in figure 4-1.

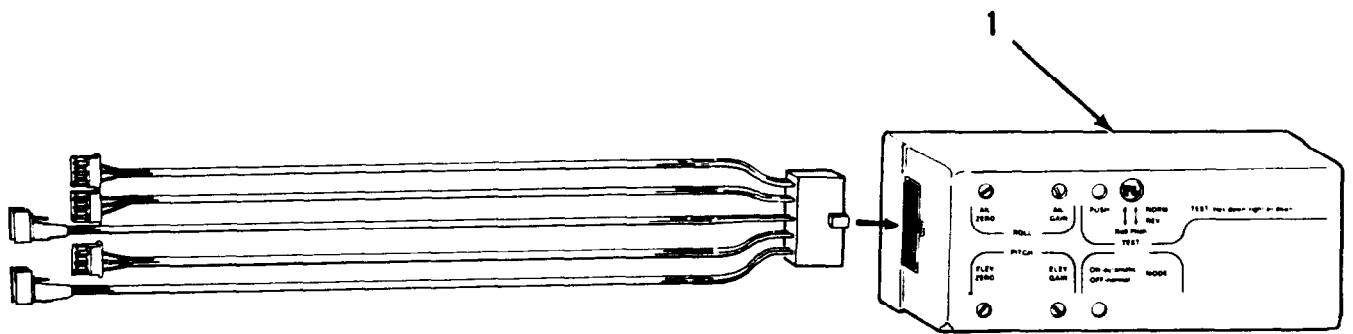

MS619677

1 Gyro assembly

Figure 4-1. Flight stabilization unit (FSU).

4-3. DESCRIPTION AND USE OF OPERATOR'S FSU CONTROLS AND INDICATORS.

The controls and indicators of the FSU are illustrated in figure 4-2 and explained in table 4-1

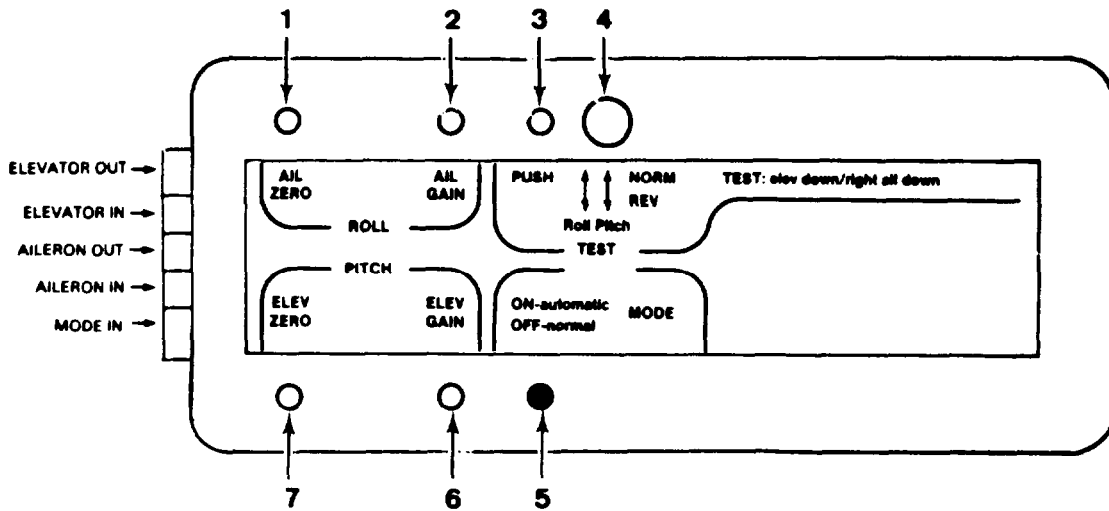

MS619678

Figure 4-2. FSU controls.

Table 4-1. FSU Controls and Indicators

Fig. 4-1 Key	Control or Indicator	Function
1	A.P. Zero	Used to align ailerons during FSU operation.
2	A.P. Gain	Used to increase or decrease aileron sensitivity during FSU operation.
3	A.P. Test Button	Used to check FSU operation.
4	A.P. NORM/REV switches	Used to change the direction of operation of the FSU.
5	Mode LED	Shows operation of FSU.
6	A.P. Gain	Used to increase or decrease elevator sensitivity during FSU operation.
7	A.P. Zero	Used to align elevator during FSU operation.

Section II. AUXILIARY EQUIPMENT ASSEMBLY AND PREPARATION FOR USE

4-4. UNPACK FLIGHT STABILIZATION KIT.

NOTE

Do not remove components from foam packaging.

- a. Open container and remove stabilizer.
- b. Verify contents per appendix D.

4.5. UNPACK FIELD SUPPORT KIT.

- a. Open container and carefully remove contents.
- b. Verify contents per appendix D.
- c. Storage of field support kit contents is the responsibility of the using unit; however, care in storage should be taken for the following items.

- Engine
- Receiver and servo/battery group
- Epoxy

4.6. INSTALLATION OF FLIGHT STABILIZATION UNIT (FSU).

- a. Procedures for FSU installation depend upon the stage of assembly of the target.
- b. Installation of the FSU during assembly is accomplished by performing installation instructions during the initial procedures.
- c. Installation of the FSU in an assembled target is accomplished by partially disassembling the target, installing the FSU, and reassembling it.

4.7. FSU INSTALLATION DURING TARGET ASSEMBLY.

- a. Obtain the items in table 3-1 and 4-2 and perform the steps outlined below. (For FSU item identification, see figure 4-1.)

Table 4-2. FSU Assembly Components

<i>Item</i>	<i>Quantity</i>
Gym Control Box	1

- b. Perform assembly steps 1 through 19 of paragraph 3-9c.
- c. Perform FSU installation procedures as outlined below.

NOTE

In order to install the FSU, a section of the fuselage must be modified.

- (1) Modify fuselage. (See fig. 4-3.)

- (a) Locate a point 2.5 inches from the top and 3.0 inches from edge of the flight control compartment.
- (b) Cut a hole approximately 1 inch in diameter in the front bulkhead of the receiver compartment using the point located above as the center point.

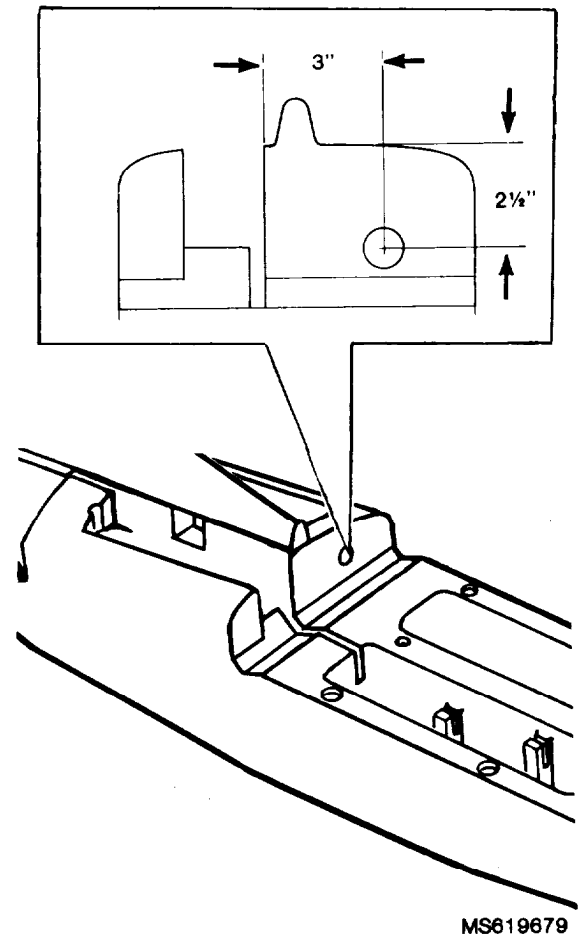
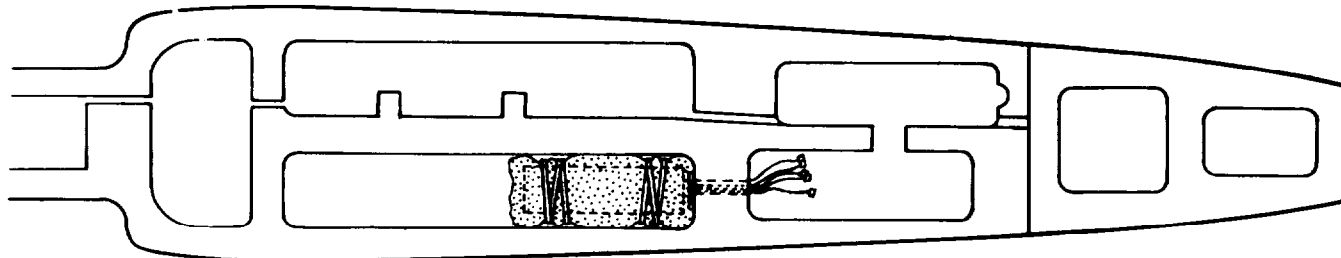

Figure 4-3. Hole for FSU connectors into receiver compartment.

CAUTION

Stabilizer is wrapped in foam packaging. Do not install FSU without foam packaging.

(2) Install FSU. Place gyro assembly into fuselage compartments and extend connectors through hole. (See fig. 4-4.) Ensure that faceplate of the FSU faces up. Check by pushing foam packaging aside.



MS619680

Figure 4-4. FSU installation.

(3) Connect gyro electronics assembly to the receiver and servo/battery group. (See fig. 4-5.) Push aside the edge of the foam packaging when making the connections.

(a) Connect the Mode In connector on the gyro control box to the AUX A channel on the receiver.

(b) Connect the AIL In connector on the gyro control box to the aileron channel on the receiver.

(c) Connect the AIL Out connector on the gyro control box to the aileron servo connector.

(d) Connect the ELE In connector on the gyro control box to the elevator channel on the receiver.

(e) Connect the ELE Out connector on the gyro control box to the elevator servo connector.

(f) Connect the throttle servo connector to the throttle channel on the receiver.

(g) Connect the battery connector to the receiver power plug on the receiver.

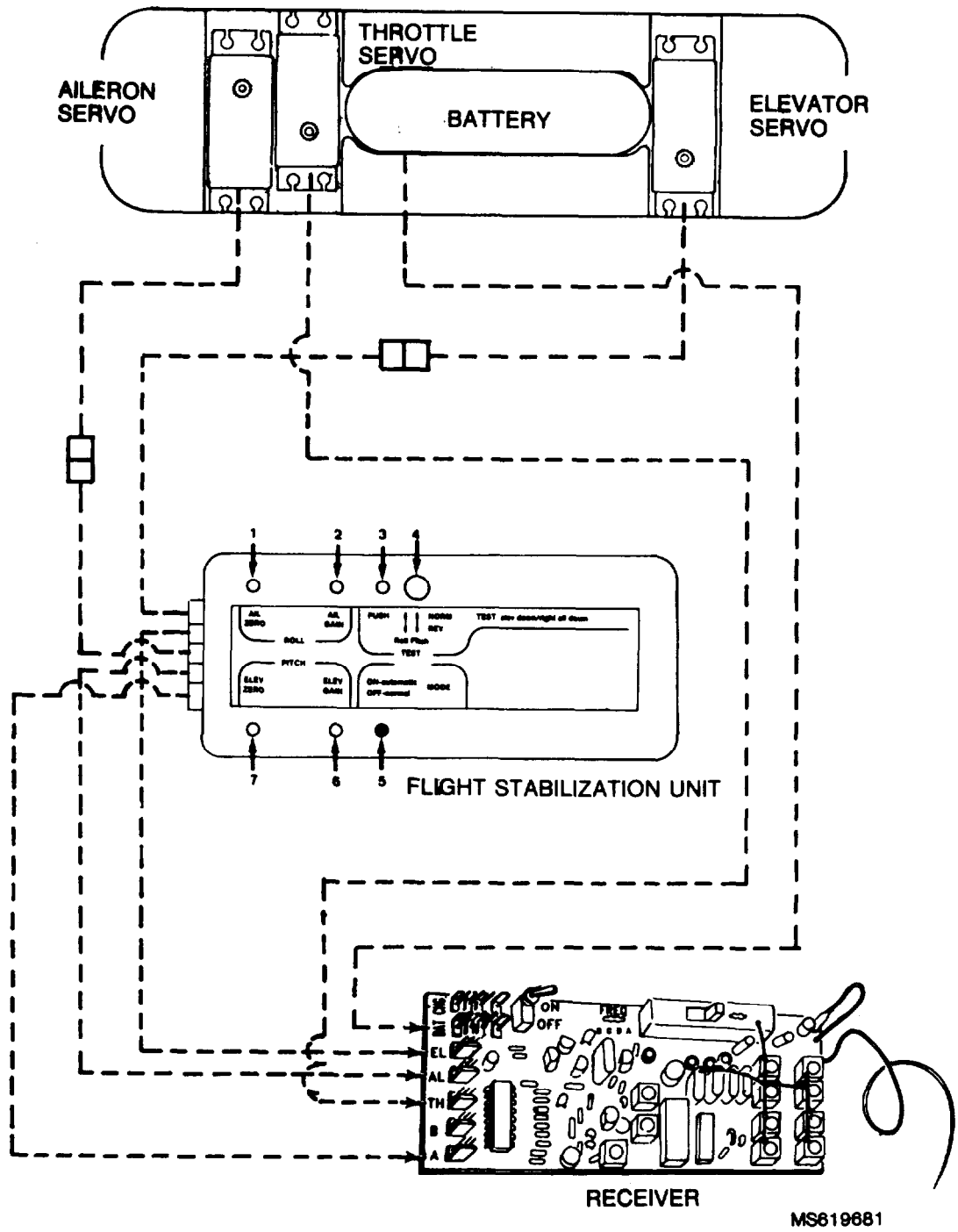

Figure 4-5. FSU and receiver and servo/battery interconnection diagram.

4-8. FSU INSTALLATION IN AN ASSEMBLED TARGET.

- a. Obtain an assembled FQM-117 B-1 and the items in table 4-2. (For FSU item identification, see figure 4-1.)
- b. Perform the procedures outline below.
 - (1) Place the target on a work table or flat surface.
 - (2) Disassemble as follows:
 - (a) Remove aileron pushrod snap lines from aileron control horns and position them out of the way for wing assembly removal.

- (b) Remove wing assembly and place in a safe area.
- (c) Remove receiver dust cover.
- (d) Disconnect receiver and servo/battery group.
 - (3) Perform FSU installation procedure in accordance with paragraph 4-7 c.1.
 - (4) Reassemble as follows:
 - (a) Reinstall wing assembly.
 - (b) Reconnect control snap links. (See fig 3-12.)
 - (c) Connect aileron pushrod snap links to aileron control horns.

Section III. OPERATION OF AUXILIARY EQUIPMENT

4-9. ALIGNMENT AND ADJUSTMENT OF AUXILIARY EQUIPMENT.

NOTE

The alignment and adjustment of the FSU must be done on a previously flown and trimmed out FQM-117 B-1.

- a. On the transmitter, position the controls as follows:

POWER SWITCH	OFF
ROLL-TRIM	MID-RANGE
PITCH-TRIM	MID-RANGE
BAND POWER SELECT SWITCH	AS REQUIRED TO MATCH RECEIVER CHANNEL
RF BAND SWITCH	AS REQUIRED TO MATCH RECEIVER CHANNEL
CHANNEL SWITCH	AS REQUIRED TO MATCH RECEIVER CHANNEL

- b. On the receiver, set the ON-OFF switch to OFF.
- c. On the transmitter, set the power switch to ON.
- d. On the receiver, set the ON-OFF switch to ON.
- e. On the transmitter, operate the Aux, channel A switch while observing the mode LED on the gyro control box. (See fig. 4-2.) When the light is on, the FSU is ON; when the light is OFF, the FSU is OFF. Turn the FSU on (light ON).
- f. Test the FSU for proper operation. (See fig. 4-2.) Press the AP test button with the tip of a pencil and observe the

result. If the unit is operating properly, the elevator and the right aileron will deflect downwards. If the elevator moves upwards, change the position of the normal/reverse pitch switch. Likewise, if the left aileron move down, change the position of the normal/reverse roll switch. Repeat the test until both the elevator and the right aileron move downwards when the AP test button is pushed.

- g. Adjust the ailerons. (See fig. 4-2.) On the transmitter, operate the Aux. Ch. A switch (which is now controlling the FSU) on and off. Observe the ailerons for any movement,

- (1) If no movement of the ailerons is observed, continue to (h).

NOTE

If some movement of the ailerons is noted at this time. the ailerons are not properly aligned. Do not adjust with the trim on the transmitter.

- (2) Align the ailerons to center by operating the AUX. Ch. A switch on the transmitter on and off while turning the AP Aileron zero trimer on the FSU until the ailerons no longer change position when the FSU is being turned on and off.

- h. Adjust the elevator. (See fig. 4-2.) On the transmitter operate the AUX Ch. A switch (which is now controlling the FSU) on and off. Observe the elevator for any movement.

- (1) If no movement of the elevator is observed, continue to (i).

NOTE

If some movement of the elevator is noted at this time. the elevator is not properly aligned. Do not adjust the elevator with the trim on the transmitter.

(2) Align the elevator to center by operating the Aux. Ch. A switch on the transmitter on and off while turning the AP elevator zero trimer on the FSU until the elevator no longer changes position when the FSU is being turned on and off.

i. These settings should produce an aerial target that maintains its trim settings when the FSU is turned on. Test fly, readjust, if necessary, using the procedures above.

j. If the target is unstable in its roll axis (if it rolls back and forth) when the FSU is engaged, turn the FSU off and land.

(1) Adjust the AP aileron gain trimmer (see fig. 4-2.) counter clockwise twenty degrees to decrease the gain.

(2) Test fly again. If the target is still unstable in its roll axis, repeat the above procedure until it is satisfactory.

k. If the target is unstable in its pitch axis (if it pitches up and down) when the FSU is engaged, turn the FSU off and land.

(1) Adjust the AP elevator gain trimmer (see fig 4-2.) counter clockwise twenty degrees to decrease the gain.

(2) Test fly again. If the target is still unstable in its pitch axis, repeat the above procedure until it is satisfactory.

l. When mission is complete, position the following controls to OFF:

- Receiver and servo/battery group power switch
- Aux. Ch. 1 (FSU)
- Transmitter power switch

4-10. OPERATION OF THE FSU.

The flight stabilization unit (FSU) is intended for training controllers only. The flight stabilization unit is an automatic pilot. The FSU will produce and maintain the aerial target in a straight and level flight. Presuming all of the adjustments have been properly made, the following actions can be expected:

a. When the FSU is engaged from the transmitter, the FSU will regain straight and level flight no matter what attitude the target was in previously. Care must be exercised that sufficient altitude is available for this; in normal practice, 200 feet is sufficient

b. If the FQM-117 B-1 is in a straight and level flight when the FSU is engaged, the FSU will maintain it in that attitude until it is either disengaged or the controller overrides the FSU with an input from the control stick. After a maneuver has been accomplished by the controller with the FSU engaged, the FSU will return the target to level flight.

c. The best way to operate the FQM-117 B-1 using the FSU is to fly the aerial target in straight and level flight and then engage the FSU to keep it in that attitude. When a deviation is desired in the flight path, disengage the FSU and make the maneuver, and then reengage the FSU. If minor flight path deviation is desired, normal stick motion will produce roll and pitch command with a slower response when the FSU pushbutton is engaged.

d. The FSU will recover the aerial target from an inverted position, but sufficient altitude must be available.

4-11. TRANSMITTER TRAINER CORD.

The transmitter trainer cord is used when training new operators or teaching new flight patterns such as the ones in figures 2-18 through 2-27. A qualified controller controls the aerial target from the primary transmitter. Control is transferred to the trainee transmitter by depressing and holding the training pushbutton (push to Train SW) on the primary transmitter. The trainee controls the aerial target through the training cable hook-up. When the pushbutton is released, control is returned to the primary transmitter and the primary controller.

4-12 TRANSMITTER TRAINER CORD ASSEMBLY PROCEDURES.

a. Obtain the following items. (For item identification, see figure 4-6.)

- Two transmitters
- Two neck straps
- One transmitter antenna
- Transmitter trainer cord from GSE field box

b. Inspect the components for damage. Repair or reject as appropriate.

c. Perform the assembly procedures as follows (See fig. 4-6):

(1) Connect the antenna to one of the transmitters. Tighten antenna sleeve "finger tight" (approximately 10-12 in/lbs). This will be the instructor unit.

(2) Attach neck straps to neck strap eyelets.

(3) Connect the transmitter trainer cord.

(a) Connect the end of the transmitter trainer cord marked T (instructor) to the TRAINER/CHARGE/EMERGENCY connector on the instructor transmitter.

(b) Connect the other end of the cord marked S (trainee) to the TRAINER/CHARGE/EMERGENCY connector on the trainee transmitter.

(4) Set the Band Power Select switches on the transmitters:

(a) Set the Band Power Select on the instructor's transmitter as required to match the receiver channel.

(b) Set the Band Power Select switch on the trainee's transmitter to TRAIN.

(5) Both transmitters must be turned ON to operate in the instructor/trainee mode.

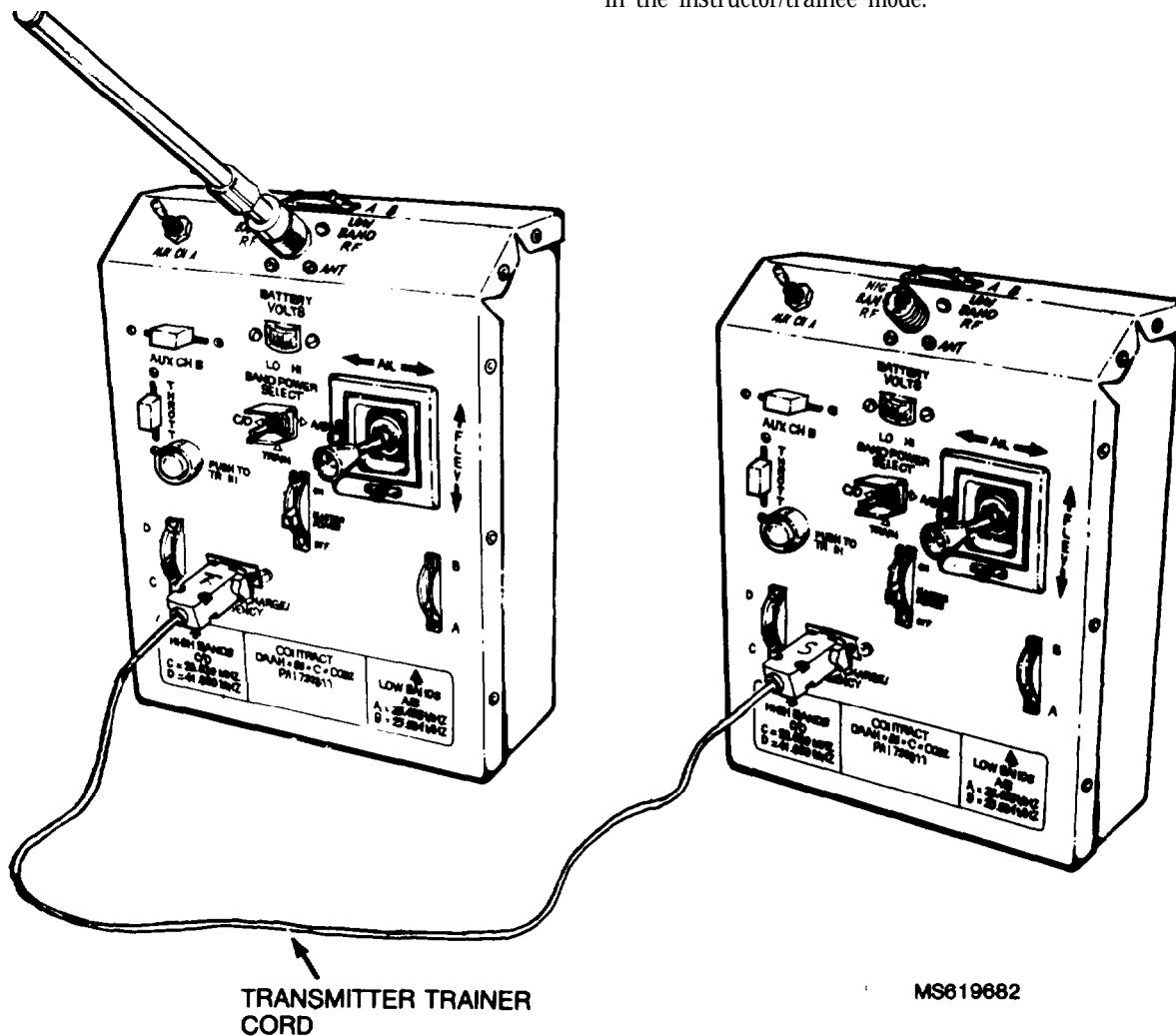

Figure 4-6. Instructor/trainee cable hookup.

CHAPTER 5

IMMEDIATE DIRECT SUPPORT MAINTENANCE INSTRUCTIONS

5-1. IMMEDIATE DIRECT SUPPORT MAINTENANCE.

No immediate direct support maintenance operations are required on the FQM-117 B-1 or FQM-117 C-1 RCMAT system.

CHAPTER 6

IMMEDIATE GENERAL SUPPORT MAINTENANCE INSTRUCTIONS

6-1. IMMEDIATE GENERAL SUPPORT MAINTENANCE.

No intermediate general support maintenance operations are required on the FQM-117 B-1 or FQM-117 C-1 RCMAT system.

**APPENDIX A
REFERENCES**

Section I. INTRODUCTION

A-1. GENERAL.

Applicable publication indexes should be consulted frequently for latest changes or revisions to the publications listed in this appendix, and for new publications relating to the material covered in this manual.

A-2. PUBLICATIONS INDEXES.

Consolidated Index of Army Publications and Blank Forms DA PAM 310-1

A-3. TECHNICAL MANUALS.

Administrative Storage of Equipment TM 74690-1
 The Army Maintenance Management Systems (TAMMS) DA PAM 738-750

A-4. FORMS.

Recommended Changes to Publications and Blank Forms DA Form 2028
 Report of Damage or Improper Shipment DD Form 6
 Quality Deficiency Report SF 368

A-5. OTHER PUBLICATIONS.

Accident Reporting and Records AR 38540
 Army Safety Program AR 385-10
 First Aid for Soldiers FM-21-11
 Noise and Conservation of Hearing TB MED 251
 Security - Department of Army Information AR 380-5
 Security Program Regulation AR 380-5

APPENDIX B

MAINTENANCE ALLOCATION CHART

Section I. INTRODUCTION

B-1. GENERAL.

The maintenance allocation chart indicates specific maintenance operations performed at proper maintenance levels. Deviation from maintenance operations allocated in the chart is authorized only upon the approval of the Commanding Office.

B-2. MAINTENANCE FUNCTIONS.

Maintenance functions will be limited to and defined as follows:

- a. ADJUST - Maintain within prescribed limits by bringing into proper or exact position, or by setting the operating characteristics to the specified parameters.
- b. ALIGN - To adjust specified variable elements of an item to bring about optimum or desired performance.
- c. CALIBRATE - To determine and cause corrections to be made or to be adjusted on instruments or test measuring and diagnostic equipment used in precision measurement. Consists of comparisons of two instruments, one of which is a certified standard of known accuracy, to detect and adjust any discrepancy in the accuracy of the instrument being compared.
- d. INSPECT - To determine the serviceability of an item by comparing its physical, mechanical, and or electrical characteristic with established standards through examination.
- e. INSTALL - The act of emplacing, seating, or fixing into position an item, part, module (compartment or assembly) in manner to allow the proper functioning of the equipment system.
- f. OVERHAUL - That maintenance effort (service/action) necessary to restore an item to a completely serviceable operational condition as prescribed by maintenance standards (e.g., DMWR) in pertinent technical publications. Overhaul does not normally return an item to like new condition. Overhaul is normally the highest degree of maintenance performed by the Army.
- g. REBUILD - Consists of those services/actions necessary for the restoration of unserviceable equipment to a like new condition in accordance with original manufacturing standards. Rebuild is the highest degree of material maintenance applied to Army equipment. The rebuild operation includes the act of returning to zero those age measurements (hours, miles, etc.) considered in classifying Army equipment components.
- h. REPAIR - The application of maintenance services (inspect, test, service, adjust, align, calibrate, replace) or other maintenance actions (welding, grinding, riveting, straightening facing, machining, or resurfacing) to assembly, module component/assembly, end item or system.
- i. REPLACE - The act of substituting a serviceable like-type part, subassembly, module (component or assembly) in a manner to allow the proper functioning of an equipment system.
- j. SERVICE - Operations required periodically to keep an item in proper operating condition, i.e., to clean, preserve, drain, paint, or to replenish fuel/lubricants/hydraulic fluids or compressed air supplies.
- k. TEST - To verify serviceability and to detect incipient failure by measuring the mechanical or electrical characteristics of an item and comparing those characteristics with prescribed standards.
- l. SYMBOLS - The uppercase letter placed in the appropriate column indicates the lowest level at which that particular maintenance function is to be performed.

B-3. EXPLANATION OF FORMAT.

- a. *Column (1) Group Number.* Column 1 lists group numbers, the purpose of which is to match components, assemblies, subassemblies, and modules with the next higher assembly.

TM 9-1550-416-14&P

b. *Column (2) Functional Group.* Column 2 lists the next higher assembly group and the item names of components, assemblies, subassemblies, and modules within the group for which maintenance is authorized.

c. *Column (3) Maintenance Functions.* Column 3 lists the eleven maintenance functions defined in B-2 above. Each maintenance function required for an item shall be specified by the symbol among those listed in d below which indicates the level responsible for the required maintenance.

d. *Column (4) Maintenance Level.* The following symbol shall be used to prescribe work function responsibility.

Code Explanation

- C Crew/Operator
- O Organizational Maintenance
- F Direct Support Maintenance
- H General Support Maintenance
- D Depot Maintenance
- X Means indeterminate time allotment for checking out maintenance functions.

e. *Column (5) Tools and Equipment.* This column is used to specify be code, those tools and test equipment required to perform the designated function.

Code Explanation

- 1 GSE Kit

Section II. MAINTENANCE ALLOCATION CHART FOR FQM-117 B-1 and FQM-117 C-1

(1) Group Number	(2) Component/ Assembly	(3) Maintenance Function	(4) Maintenance Level					(5) Tools and Equipment
			unit		Intermediate		Depot	
			C	O	F	H	D	
0100	Aircraft Kit FQM-117B-1& FQM-117C-1							
0101	Fuselage Assembly	Inspect	X	X				
		Test	X	X				
		Service	X	X				
		Install	X	X				
		Replace	X	X				
		Repair	X	X				1
0102	Wing Assembly	Inspect	X	X				
		Test	X	X				
		Service	X	X				
		Install	X	X				
		Replace	X	X				
		Repair	X	X				1
0103	Horizontal Stabilized	Inspect	X	X				
		Test	X	X				

Section II. MAINTENANCE ALLOCATION CHART FOR FQM-117 B-1 and FQM-117 C-1- Cont.

(1) Group Number	(2) Component/ Assembly	(3) Maintenance Function	(4) MaintenanceLevel					(5) Tools and Equipment
			Unit		Intermediate		Depot	
			C	O	F	H	D	
0104	Elevator Assembly Vertical Stabilizer	Service	X	X				1
		Install	X	X				
		Replace	X	X				
		Repair	X	X				
		Inspect	X	X				
		Test	X	X				
0105	Engine Assembly	Service	X	X				1
		Install	X	X				
		Replace	X	X				
		Repair	X	X				
		Inspect	X	X				
		Test	X	X				
0106	Fuel Tank Assembly	Service	X	X				1
		Install	X	X				
		Replace	X	X				
		Repair	X	X				
		Inspect	X	X				
		Test	X	X				
0107	Receiver and Servo/Battery Group	Service	X	X				1
		Install	X	X				
		Replace	X	X				
		Repair	X	X				
		Inspect	X	X				
		Test	X	X				
0108	Control Linkage Assemblies	Service	X	X				1
		Install	X	X				
		Replace	X	X				
		Repair	X	X				
		Inspect	X	X				
		Test	X	X				

Section II. MAINTENANCE ALLOCATION CHART FOR FQM-117 B-1 and FQM-117 C-1 - Cont.

(1) Group Number	(2) Component/ Assembly	(3) Maintenance Function	(4) Maintenance Level					(5) Tools and Equipment
			Unit		Intermediate		Depot	
			C	O	F	H	D	
0200	TRANSMITTER KIT							
0201	Control Transmitter	Inspect	X	X				
		Test	X	X				
		Service	X	X				
		Install	X	X				
		Replace	X	X				1
0202	Antenna	Inspect	X	X				
		Test	X	X				
		Service	X	X				
		Install	X	X				
		Replace	X	X				1
0203	Neck Strap	Inspect	X	X				
		Test	X	X				
		Service	X	X				
		Install	X	X				
		Replace	X	X				1
0204	Transmitter Battery	Inspect	X	X				
		Test	X	X				
		Service	X	X				
		Install	X	X				
		Replace	X	X				1
0300	GROUND SUP- PORT EQUIP- MENT KIT- FIELD BOX							
0301	Nicad Battery	Inspect	X	X				
		Test	X	X				
		Service	X	X				
		Install	X	X				
		Replace	X	X				1
0302	Starter	Inspect	X	X				
		Test	X	X				
		Service	X	X				
		Install	X	X				
		Replace	X	X				1

Section II. MAINTENANCE ALLOCATION CHART FOR FQM-117 B-1 and FQM-117 C-1- Cont.

(1) Group Number	(2) Component/ Assembly	(3) Maintenance Function	(4) Maintenance Level					(5) Tools and Equipment
			Unit		Intermediate		Depot D	
			C	O	F	H		
0303	Fuel Pump	Inspect	X	X				
		Test	X	X				
		Service	X	X				
		Install	X	X				
		Replace	X	X				
0304	Fuel Container	Inspect	X	X				1
		Test	X	X				
		Service	X	X				
		Install	X	X				
		Replace	X	X				
0305	Power Panel	Inspect	X	X				
		Test	X	X				
		Service	X	X				
		Install	X	X				
		Replace	X	X				
0306	Case, Plastic	Inspect	X	X				1
		Test	X	X				
		Service	X	X				
0307	Tool Set	Inspect	X	X				
		Test	X	X				
		Service	X	X				
		Install	X	X				
		Replace	X	X				
0308	Emergency Power Cable	Inspect	X	X				1
		Test	X	X				
		Service	X	X				
		Install	X	X				
		Replace	X	X				
0309	Glow Plug Clip	Inspect	X	X				1
		Test	X	X				
		Service	X	X				
		Install	X	X				
		Replace	X	X				
		Repair	X	X				

Section II. MAINTENANCE ALLOCATION CHART FOR FQM-117 B-1 and FQM-117 C-1- Cont.

(1) Group Number	(2) Component/ Assembly	(3) Maintenance Function	(4) Maintenance Level					(5) Tools and Equipment
			Unit		Intermediate		Depot	
			C	O	F	H	D	
0310	Multimeter	Inspect	X	X				1
		Test	X	X				
		Service	X	X				
		Replace	X	X				
0311	Transmitter Trainer Cord	Inspect	X	X				1
		Test	X	X				
		Service	X	X				
		Replace	X	X				
0400	GROUND SUP- PORT EQUIP- MENT KIT - CHARGER							
0401	Charger	Inspect	X	X				1
		Test	X	X				
		Service	X	X				
		Install	X	X				
		Replace	X	X				
0402	Charge Cables	Inspect	X	X				1
		Test	X	X				
		Service	X	X				
		Install	X	X				
		Replace	X	X				
0500	FLIGHT STA- BILIZATION KIT							
0501	Flight Stabil- ization Unit	Inspect	X	X				1
		Test	X	X				
		Service	X	X				
		Install	X	X				
		Replace	X	X				
		Align	X	X				

**Section III. TOOL AND TEST EQUIPMENT REQUIREMENTS FOR FQM-117B-1
and FQM-117C-1**

Tool or Test Equipment Reference Code	Maintenance Level	Nomenclature	National/NATO Stock Number	Tool Number
1	C	GSE Kit	1430-01-313-8344	4Y521-720030

APPENDIX C
ORGANIZATIONAL, DIRECT SUPPORT,
AND GENERAL SUPPORT MAINTENANCE
REPAIR PARTS AND SPECIAL TOOLS LIST

Section I. INTRODUCTION

C-1. SCOPE.

- a. This appendix lists repair parts, and special tools required for operation and performance of organizational, direct support and general support maintenance of the FQM-117 B-1 and FQM-117 C-1 Radio Controlled Miniature Aerial Target (RCMAT) System.
- b. No additional repair parts or special tools are required. All authorized repair parts are located in the field support kit listing of Appendix D.
- c. FQM-117 B-1 and FQM-117 C-1 RCMAT and Auxiliary Equipment is authorized by Common Table Allowances CTA 50-909 and CTA 50-970.

**APPENDIX D
COMPONENTS OF END ITEM AND BASIC ITEMS LIST**

Section I. INTRODUCTION

D-1. SCOPE.

This appendix lists components of end item and basic issue items for the FQM-117 B-1 and FQM-117 C-1 Radio Controlled Miniature Aerial Target (RCMAT) to help inventory items required for safe and efficient operation.

D-2. GENERAL.

a. *Section II. Components of End Item.* This listing is for informational purposes only, and is not authority to requisition replacements. These items are part of the end item, but are removed and separated, packaged for transportation or shipment. As part of the end item, these items must be with the end item whenever it is issued or transferred between property accounts. Illustrations are furnished to assist you in identifying the items.

b. *Section III. Basic Issue Items.* There are no Basic Issue Items authorized with this equipment.

D-3. EXPLANATION OF COEI COLUMNS LIST.

a. *Column (1) - Illustration Number (Illus Number).* This column indicates the number of the illustration in which the item is shown. The notation N/S indicates that there is no drawing of this item.

b. *Column (2) - National Stock Number, or FSCM-Mfr Part Number.* This column indicates the National Stock Number assigned to the item and will be used for requisitioning purposes. Items identified by FSCM and Mfr part number can be ordered through manufacturer on local purchase basis only.

c. *Column (3) - Description.* This column indicates the Federal item name and if required, a minimum description to identify and locate the item.

d. *Column (4) - Unit of Measure (U/M).* This column indicates the measure used in performing the actual operational maintenance function. This measure is expressed by a two-character alphabetical abbreviation (e.g., ea, in, pr).

e. *Column (5) - Quantity Required (Qty req).* This column indicates the quantity of the item authorized to be used with/on the equipment.

Section II. COMPONENTS OF END ITEM

(1) Illustration		(2) Army Stock Number or FSCM-MFR Part No.	(3) Description	(4) U/M	(5) Qty. Req.
Figure	Item				
No.	No.				
D-1		1430-01-313-8342	KIT, AIRCRAFT, FQM-117B-1		
D-1		4Y521-720083	Airframe Assembly	Ea.	3
D-1	1	4Y521-720002	Wing	Ea.	1
D-1	2	4Y521-720128	Canopy	Ea.	1
D-1	8	4Y521-720104	Fuselage	Ea.	1
D-1	12	4Y521-720107	Horizontal Stabilizer	Ea.	1

Section II. COMPONENTS OF END ITEM - Cont.

(1) Illustration		(2)	(3)	(4)	(5)
Figure No.	Item No.	Army Stock Number or FSCM-MFR Part No.	Description	U/M	Qty. Req.
D-1	13	4Y521-720105	Vertical Stabilizer	Ea.	1
D-1	15	4Y521-720129	Receiver Dust Cover	Ea.	1
D-1	14	4Y521-720041	Receiver Set, MIG-27	Ea.	1
D-1		4Y521-720301	Receiver	Ea.	1
D-1		4Y521-720331	Receiver Antenna	Ea.	1
D-1		4Y521-720330	Rubber Band	Ea.	2
D-1		4Y521-720132	Small Foam Latex Pad	Ea.	1
D-1		4Y521-720110	Modified Foam Receiver Mounting Plug	Ea.	1
D-1	10	4Y521-720040	Servo/Battery Group	Ea.	1
D-1		4Y521-720302	Servo with Arm	Ea.	3
D-1		4Y521-720309	Battery Pack	Ea.	1
D-1		4Y521-720108	Foam Servo Mounting Plug	Ea.	1
N/S		4Y521-720420	Long Rod with Links (taped to main body)	Ea.	3
N/S		4Y521-720941	Accessory Box, MIG-27	Ea.	1
D-1		4Y521-720506	Fuel Tank Set	Ea.	1
D-1	7	4Y521-720526	Fuel Tank with Tubing	Ea.	3
D-1	3	4Y521-720504	Engine with Glow Plug	Ea.	1
D-1	5	4Y521-720505	Muffler	Ea.	1
N/S		4Y521-720060	Engine Parts Set	Ea.	1
N/S		4Y521-720409	Engine Mounting Screws	Ea.	4
N/S		4Y521-720509	Muffler Screws	Ea.	2
D-1	6	4Y521-720516	Muffler Extension	Ea.	1
N/S		4Y521-720612	Aluminum Foil Sheet	Ea.	3
D-1		4Y521-720330	Rubber Band	Ea.	6
D-1	11	4Y521-720106	Ventral Fin	Ea.	3
N/S		4Y521-720062	Adhesive Set, MIG-27	Ea.	1
N/S		4Y521-720605	Epoxy	Pr.	2
N/S		4Y521-720607	Mixing Stick	Ea.	12
N/S		4Y521-720606	Mixing Cup	Ea.	12

Section II. COMPONENTS OF END ITEM - Cont.

Illustration		(2)	(3)	(4)	(5)
Figure	Item	Army Stock Number or FSCM-MFR	Description	U/M	Qty. Req.
No.	No.	Part No.			
D-1	9	4Y521-720051	Wing Mounting Kit	Ea.	1
D-1		4Y521-720401	Wing Hold Down Bolt	Ea.	6
D-1		4Y521-720402	Wing Bolt Washer	Ea.	12
D-1		4Y521-720403	Wing Nut	Ea.	6
N/S		4Y521-720421	Short Rod with Links	Ea.	6
D-1		4Y521-720061	Wooden Prop Bag	Ea.	1
D-1	4	4Y521-720508	Wooden Prop	Ea.	10
D-2		1430-01-313-8340	KIT, AIRCRAFT, FQM-117C-1		
D-2		4Y521-720085	Aircraft Assembly	Ea.	3
D-2	9	4Y521-720120	Right Foam Wing	Ea.	1
D-2	1	4Y521-720121	Left Foam Wing	Ea.	1
D-2	3	4Y521-720124	Vertical Fuselage Angle	Ea.	1
D-2	2	4Y521-720125	Horizontal Fuselage Angle	Ea.	1
N/S		4Y521-720084	Accessory Box, F-16	Ea.	1
D-2	10	4Y521-720039	Receiver Set, F-16	Ea.	1
D-2		4Y521-720301	Receiver	Ea.	1
D-2		4Y521-720331	Receiver Antenna	Ea.	1
D-2		4Y521-720132	Small Foam Latex Pad	Ea.	2
D-2	11	4Y521-720040	Servo/Battery Group	Ea.	1
D-2		4Y521-720302	Servo with Arm	Ea.	3
D-2		4Y521-720309	Battery Pack	Ea.	1
D-2		4Y521-720108	Foam Servo Mounting Plug	Ea.	1
D-2	4	4Y521-720504	Engine with Glow Plug	Ea.	1
D-2	7	4Y521-720505	Muffler	Ea.	1
N/S		4Y521-720060	Engine Parts Set	Ea.	1
N/S		4Y521-720409	Engine Mounting Screws	Ea.	4
N/S		4Y521-720509	Muffler Screws	Ea.	2
D-2	6	4Y521-720516	Muffler Extension	Ea.	1
D-2		4Y521-720404	Medium Rod with Links	Ea.	4
D-2		4Y521-720421	Short Rod with Links	Ea.	4
D-2		4Y521-720213	Elevator Joiner with Horn	Ea.	3

Section II. COMPONENTS OF END ITEM - Cont.

(1) Illustration		(2) Army Stock Number or FSCM-MFR	(3) Description	(4) U/M	(5) Qty. Req.
Figure	Item	Part No.			
No.	No.				
N/S		4Y521-720088	Adhesive Set, F-16	Ea.	1
N/S		4Y521-720605	Epoxy	Pr.	3
N/S		4Y521-720607	Mixing sticks	Ea.	12
N/S		4Y521-720606	Mixing cups	Ea.	12
N/S		4Y521-720102	Throttle Pushrod Assembly with Links	Ea.	4
D-2		4Y521-720330	Rubber Band	Ea.	12
D-2		4Y521-720211	Dowel	Ea.	16
D-2		411521-720506	Fuel Tank Set	Ea.	1
D-2	8	4Y521-720526	Fuel Tank with Tubing	Ea.	3
D-2		4Y521-720061	Wooden Prop Bag	Ea.	1
D-2	5	411521-720508	Wooden Prop	Ea.	10
D-3		1430-01-313-8344	KIT, GROUND SUPPORT EQUIPMENT (GSE)		
D-3		4Y521-720086	GSE Master Charger Set	Ea.	1
D-3	1	4Y521-720314	GSE Master Charger	Ea.	1
D-3	9	4Y521-720343	GSE Field Box or Transmitter Charge Cables	Ea.	5
D-3	10	4Y521-720342	Receiver Charge Cables/Short	Ea.	4
D-3	11	4Y521-720341	Receiver Charge Cable/ Medium	Ea.	4
D-3	12	4Y521-720340	Receiver Charge Cables/ Long	Ea.	4
D-3		4Y521-720033	GSE Field Box Set	Ea.	1
D-3	3	4Y521-720619	GSE Field Box	Ea.	1
D-3		4Y521-720315	12 Volt Starter Battery (installed)	Ea.	1
D-3		4Y521-720317	12 Volt Fuel Pump with Tubing (installed)	Ea.	1
D-3		4Y521-720511	Fuel Can with Cap Fittings (installed)	Ea.	1
D-3		411521-720318	Power Panel (installed)	Ea.	1
D-3	2	4Y521-720316	12 Volt Starter	Ea.	1
D-3	4	411521-720319	Glow Plug Clip	Ea.	3
D-3	5	4Y521-720325	Emergency Power Cable	Ea.	1

Section II. COMPONENTS OF END ITEM - Cont.

(1) Illustration		(2) Army Stock Number or FSCM-MFR	(3) Description	(4) U/M	(5) Qty. Req.
Figure	Item	Part No.			
No.	No.				
D-3	7	4Y521-720324	Transmitter Trainer Cord	Ea.	1
D-3	8	411521-720320	DC Voltmeter	Ea.	1
D-3	6	4Y521-720048	Tool Set	Ea.	1
D-3		4Y521-720601	4-Way Prop Wrench	Ea.	1
N/S		4Y521-720602	Large Phillips Screwdriver	Ea.	1
N/S		411521-720603	Small Phillips Screwdriver	Ea.	1
D-3		4Y521-720604	Small Standard Screwdriver	Ea.	1
N/S		4Y521-720613	Foam Saw	Ea.	1
N/S		4Y521-720614	Needle Nose Pliers	Ea.	1
N/S		4Y521-720616	4-40 Allen Wrench	Ea.	1
N/S		411521-720617	6-32 Allen Wrench	Ea.	1
N/S		4Y521-720615	Hemostat	Ea.	4
D-4		1430-01-313-8343	KIT, TRANSMITTER		
D-4		4Y521-720347	Transmitter Set	Ea.	2
D-4	2	4Y521-720311	Transmitter, Multi-Band	Ea.	1
N/S		4Y521-720339	Transmitter Battery (installed)	Ea.	1
D-4	3	4Y521-720312	Neck Strap	Ea.	1
D-4	1	4Y521-720313	Collapsible Antenna	Ea.	1
D-5	1	1430-01-313-8445	KIT, STABILIZATION		
D-5		411521-720326	Flight Stabilization Unit (FSU)	Ea.	1
D-5		4Y521-720349	Flight Stabilization Wiring Harness	Ea.	1
D-5		4Y521-720330	Rubber Band	Ea.	2
D-5		4Y521-720133	Large Foam Latex Pad	Ea.	1
D-6		1430-01-313-8341	KIT, FIELD SUPPORT (FSK)		
D-6	1	4Y521-720612	Aluminum Foil Sheets	Ea.	50
D-6	2	411521-720605	Epoxy	Pr.	20
D-6		411521-720082	Mixing Cup Set	Ea.	
D-6	3	4Y521-720606	Mixing Cups	Ea.	100

Section II. COMPONENTS OF END ITEM - Cont.

(1) Illustration		(2) Army Stock Number or FSCM-MFR	(3) Description	(4) U/M	(5) Qty. Req.
Figure	Item	Part No.			
No.	No.				
D-6		4Y521-720081	Mixing Stick Set	Ea.	
D-6	4	4Y521-720607	Mixing Sticks	Ea.	100
D-6	5	4Y521-720517	Fuel Tubing	Ft.	10
D-6	6	4Y521-720348	Rubber Band	Lbs.	1/4
D-6		4Y521-720061	Wooden Prop. Bag	Ea.	20
D-6	7	4Y521-720508	Wooden Prop.	Ea.	10
D-6	16	4Y521-720136	Throttle Tubing Assembly, Mig-27	Ea.	3
D-6	18	4Y521-720421	Short Rod With Links	Ea.	6
D-6	17	4Y521-720420	Long Rod With Links	Ea.	3
D-6	8	4Y521-720526	Fuel Tank With Tubing	Ea.	5
D-6		4Y521-720057	Engine Material Set	Ea.	5
D-6	9	4Y521-720504	Engine With Glow Plug	Ea.	1
D-6	10	4Y521-720505	Muffler	Ea.	1
D-6	11	4Y521-720060	Engine Parts Set	Ea.	1
D-6		4Y521-720409	Engine Mounting Screws	Ea.	4
D-6		4Y521-720509	Muffler Screws	Ea.	2
D-6		4Y521-720516	Muffler Extension	Ea.	1
D-6	12	4Y521-720079	GSE Small Parts Set	Ea.	1
D-6		4Y521-720601	4-Way Prop. Wrench	Ea.	1
D-6		4Y521-720616	4-40 Allen Wrench	Ea.	1
D-6		4Y521-720617	6-32 Allen Wrench	Ea.	1
D-6		4Y521-720615	Hemostat	Ea.	2
D-6		4Y521-720610	Starter Inserts	Ea.	5
D-6		4Y521-720059	Glow Plug Set	Ea.	1
D-6	13	4Y521-720507	Glow Plug with Washer	Ea.	20
D-6	15	4Y521-720063	Engine Mounting Screw Set	Ea.	1
D-6		4Y521-720409	Engine Mounting Screw	Ea.	30
D-6	19	4Y521-720080	Nylon Parts Set	Ea.	1
D-6		4Y521-720413	Snap Links	Ea.	20
D-6		4Y521-720419	Small Control Horns	Ea.	20
D-6		4Y521-720412	Large Control Horns	Ea.	20
D-6	14	4Y521-720044	Engine Spare Set	Ea.	1
D-6		4Y521-720518	Prop. Stud	Ea.	5

Section II. COMPONENTS OF END ITEM - Cont.

Illustration		(2)	(3)	(4)	(5)
Figure	Item	Army Stock Number or FSCM-MFR	Description	U/M	Qty. Req.
No.	No.	Part No.			
D-6		4Y521-720519	Prop. Washer	Ea.	5
D-6		4Y521-720520	Prop Nut	Ea.	5
D-6		4Y521-720521	Carburetor	Ea.	2
D-6		4Y521-720522	Needle Valve Assembly	Ea.	3
D-6		4Y521-720509	Muffler Screws	Ea.	6
D-6		4Y521-720056	Servo Ann Set	Ea.	1
D-6	20	4Y521-720303	Servo Ann	Ea.	20
D-6	21	4Y521-720077	Servo Screw set	Ea.	1
D-6		4Y521-720307	Servo screw	Ea.	20
D-4	22	4Y521-720040	Servo/Battery Group	Ea.	5
D-6		4Y521-720302	Servo With Ann	Ea.	3
D-6		4Y521-720309	Battery Pack	Ea.	1
D-6		4Y521-720108	Foam Servo Mounting Plug	Ea.	1
D-6	23	4Y521-720041	Receiver Set	Ea.	5
D-6		4Y521-720301	Receiver	Ea.	1
D-6		4Y521-720331	Receiver Antenna	Ea.	1
D-6		4Y521-720330	Rubber Band	Ea.	2
D-6		4Y521-720132	Small Foam Latex Pad	Ea.	1
D-6		4Y521-720110	Modified Foam Receiver Mounting Plug	Ea.	1
D-6		4Y521-720087	Receiver Antenna Set	Ea.	1
D-6	24	4Y521-720331	Receiver Antenna	Ea.	5
D-6	25	4Y521-720078	Wing Mounting Set	Ea.	1
D-6		4Y521-720401	Wing Hold Down Bolt	Ea.	10
D-6		4Y521-720402	Wing Bolt Washer	Ea.	20
D-6		4Y521-720403	Wing Nut	Ea.	30

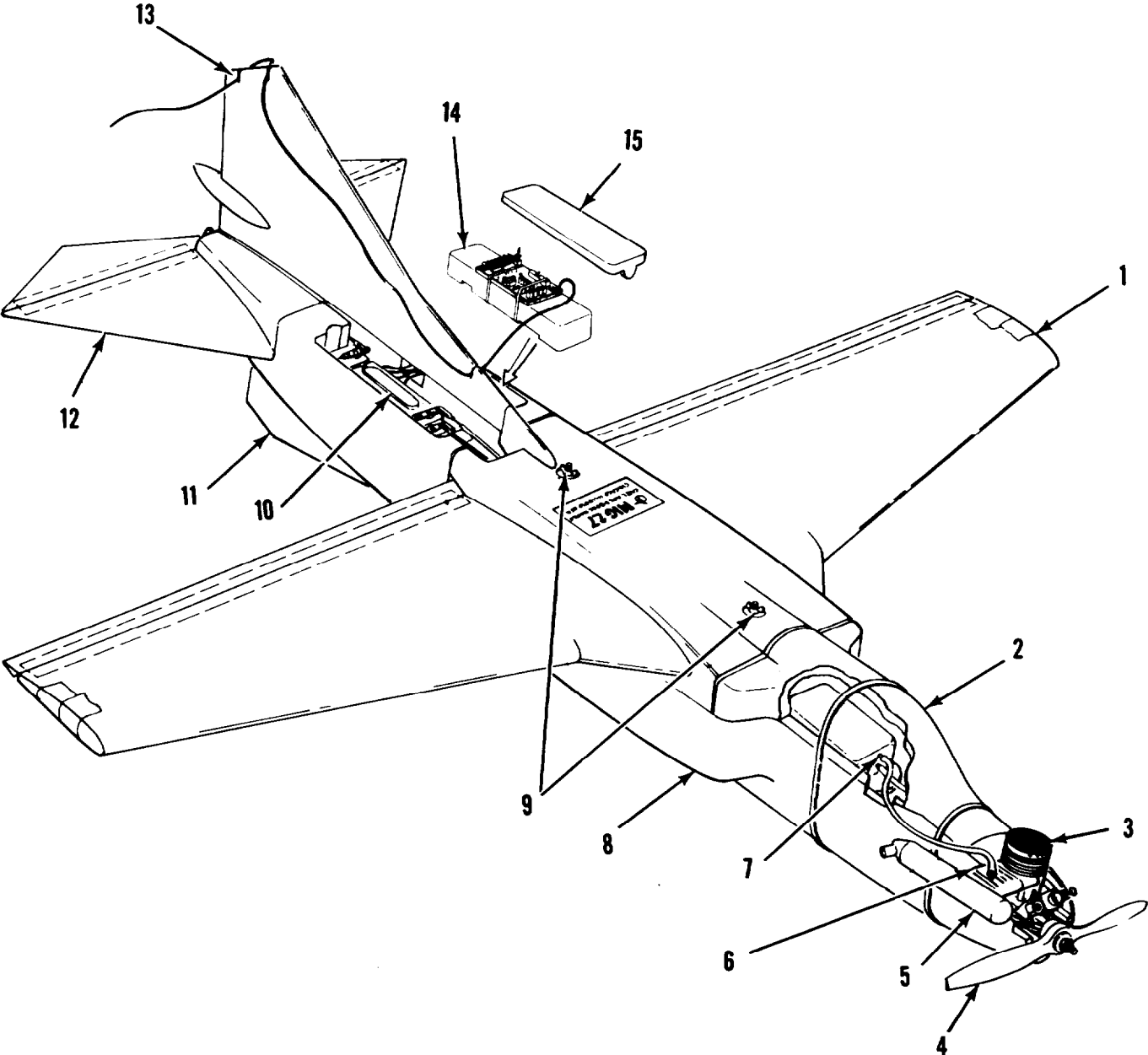

Figure D-1. Aircraft kit contents/FQM-117 B-1.

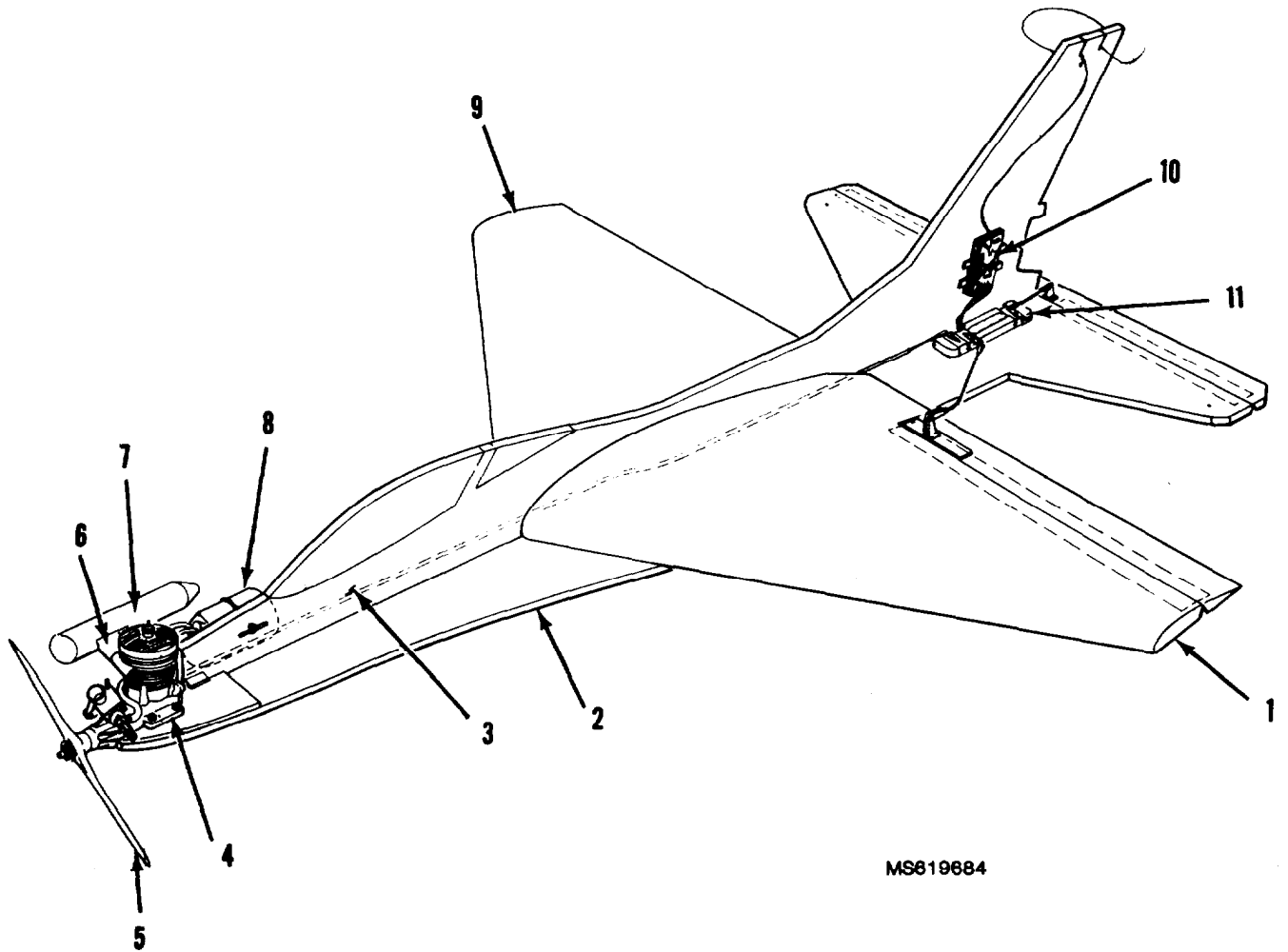
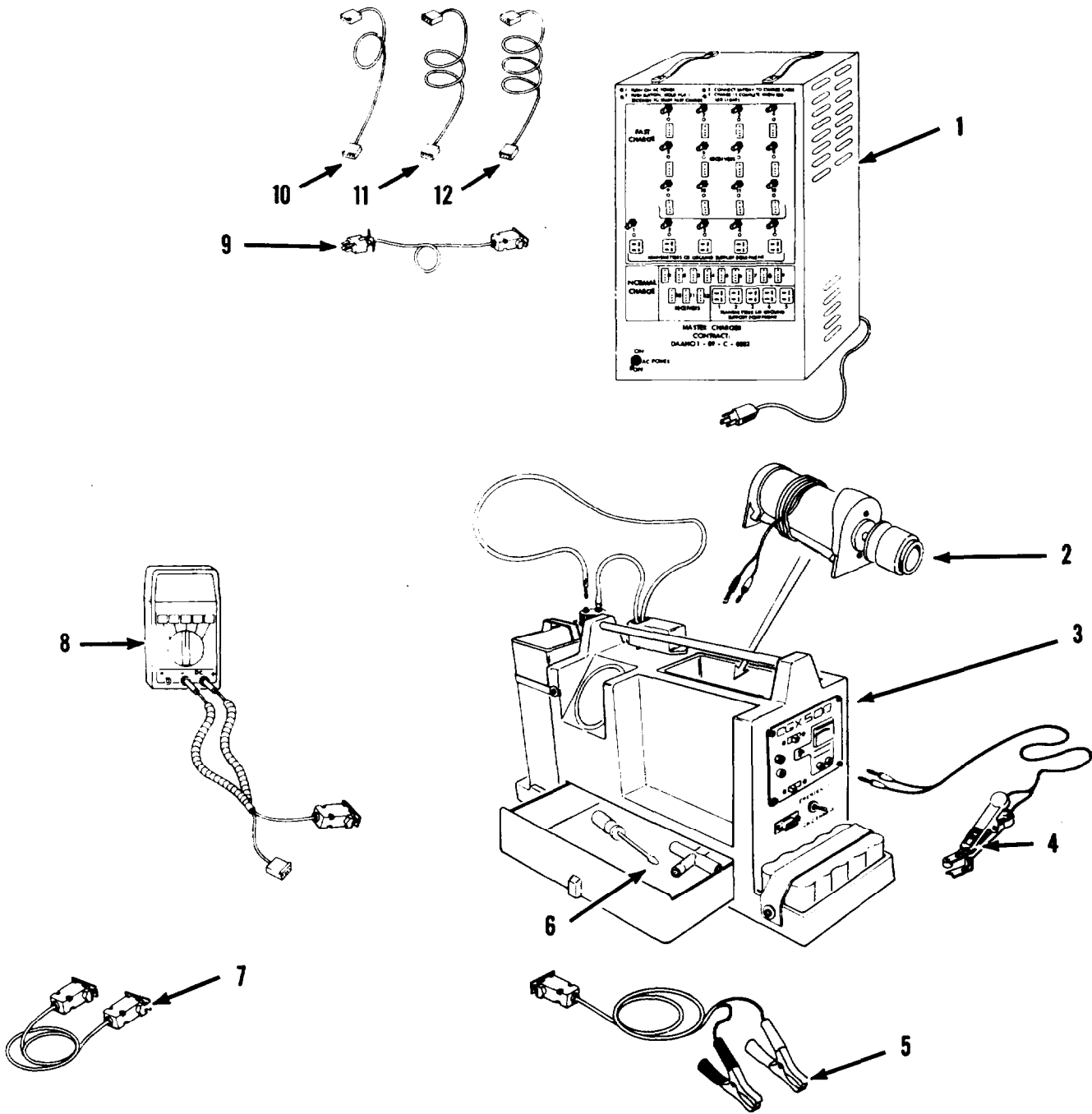
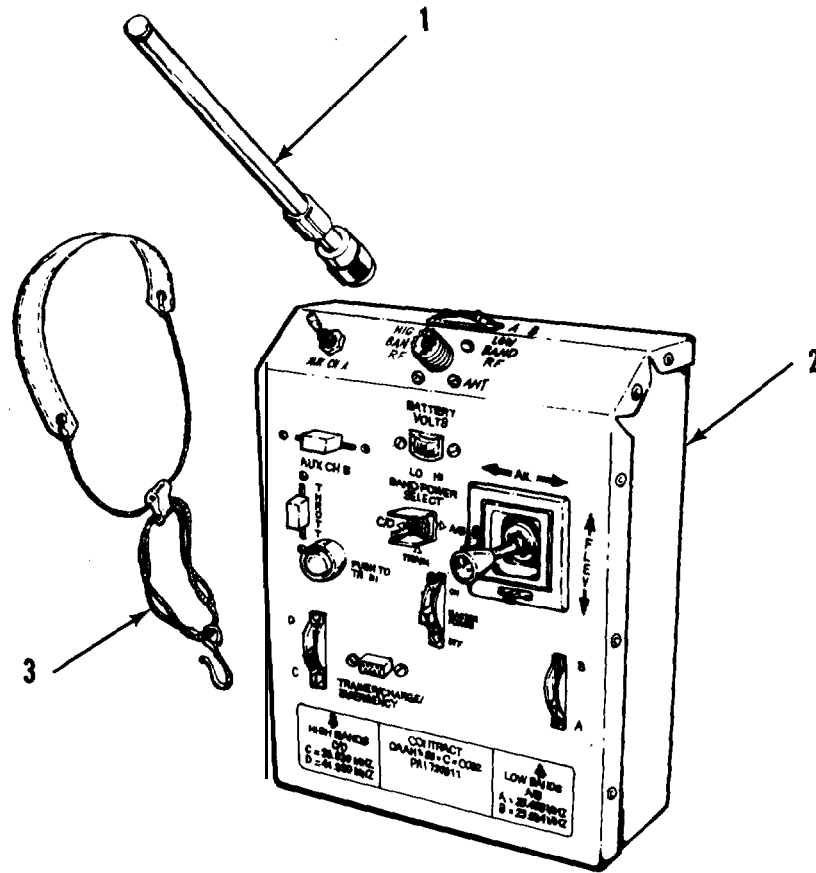

Figure D-2. Aircraft kit contents/FQM- 117 C-1.



MS619685

Figure D-3. Ground support equipment (GSE) kit contents.



MS619686

Figure D-4. Transmitter kit contents.

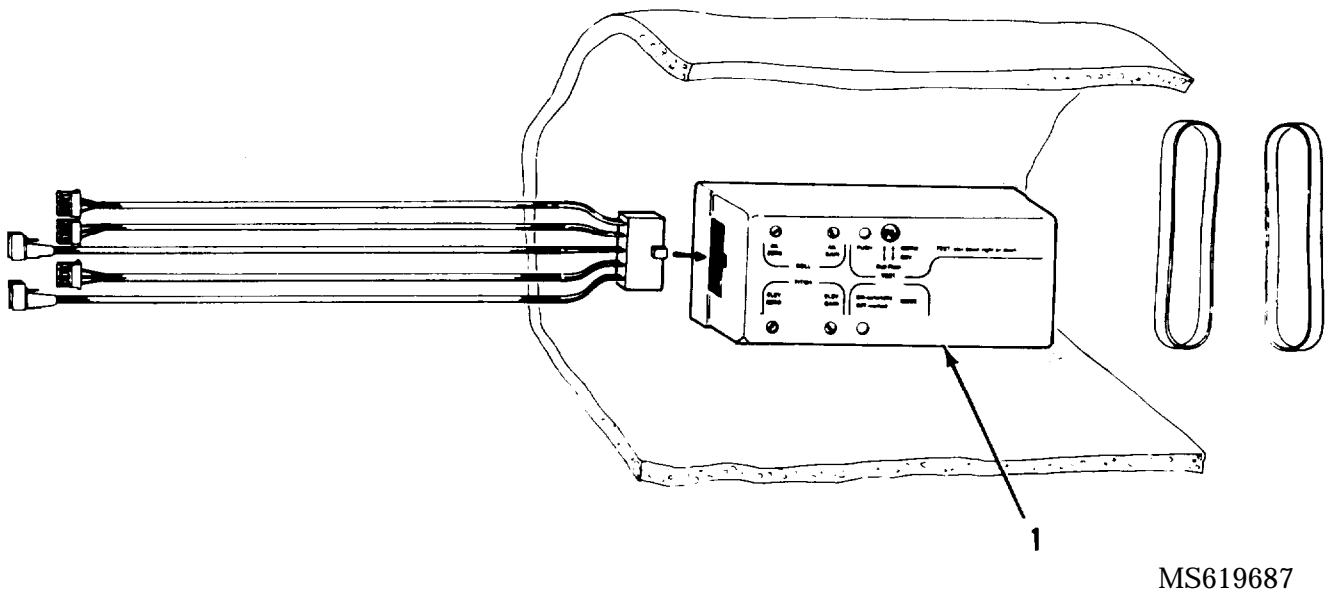

MS619687

Figure D-5. Stabilization kit contents.

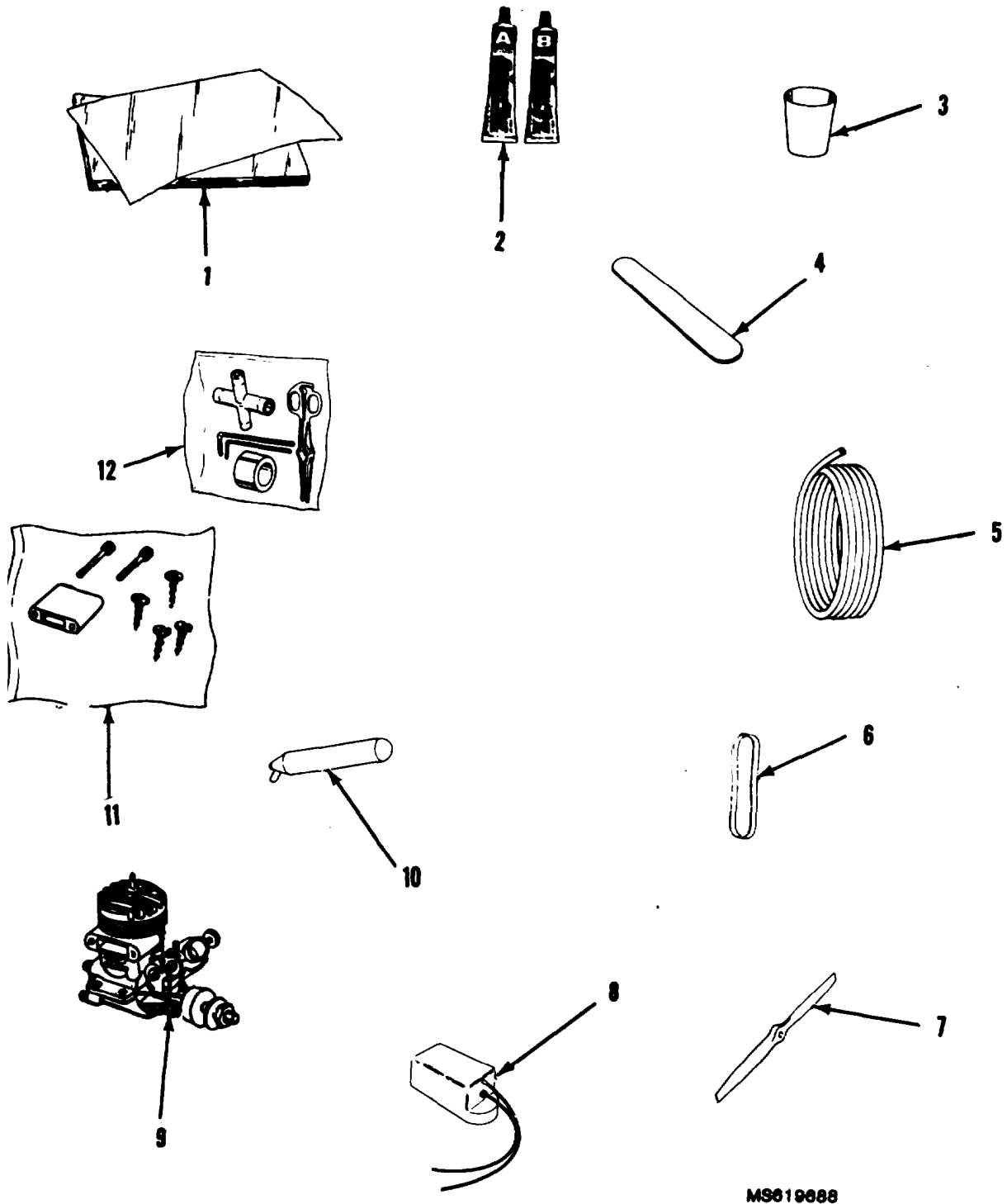
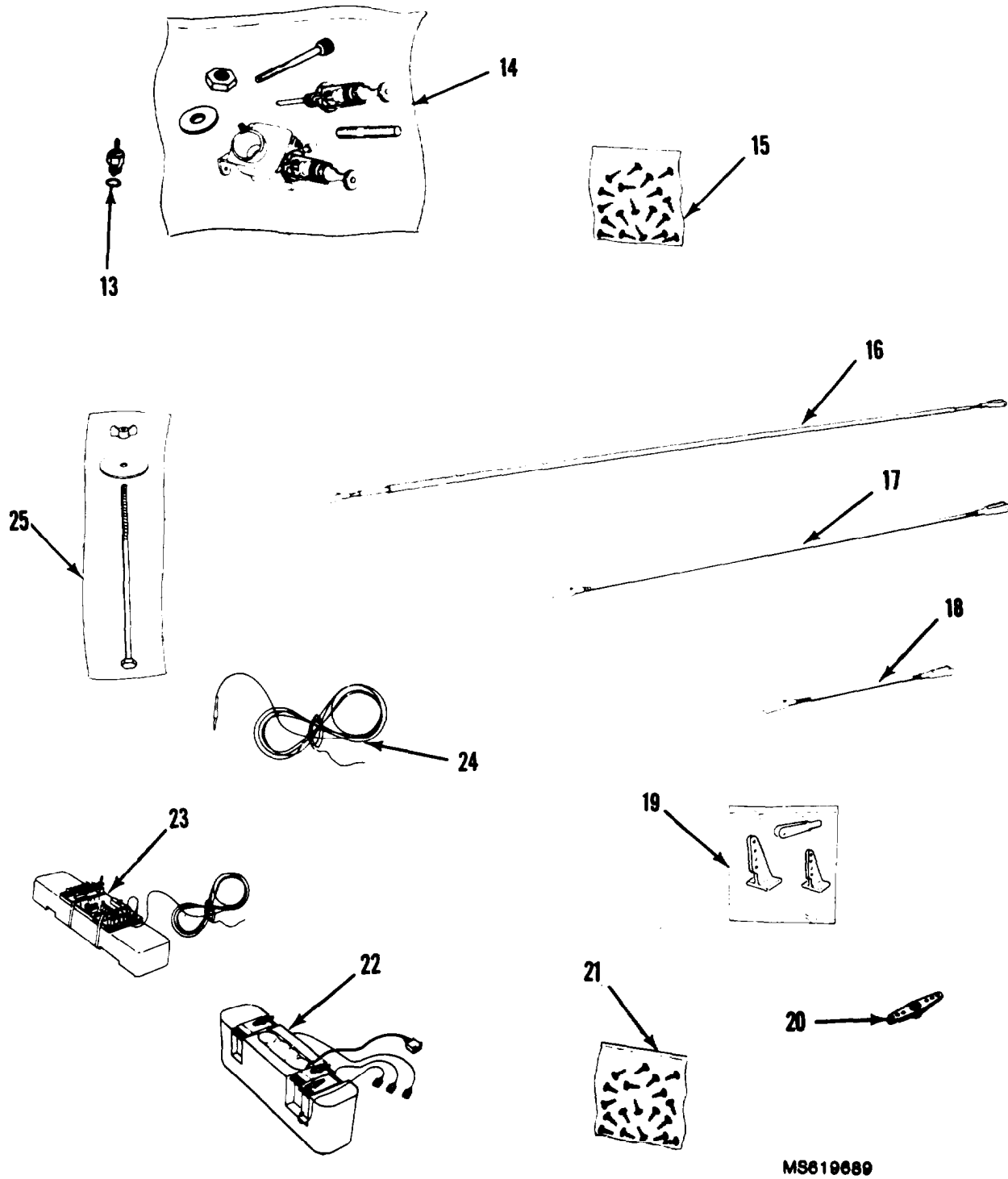

Figure D-6. Field support kit (FSK) contents
(Sheet 1 of 2)



MS619689

Figure D-6. Field support kit (FSK) contents.
(Sheet 2 of 2)

APPENDIX E
EXPENDABLE SUPPLIES AND MATERIALS LIST

Section I. INTRODUCTION

E-1. SCOPE.

This appendix lists expendable supplies and materials you will need to operate and maintain the FQM-117B-1 and FQM-117C-1. These items are authorized to you by CTA 50-909, Expendable Items (Except Medical, Class V, Repair Parts, and Heraldic Items).

E-2. EXPLANATION OF COLUMNS.

a. Column (1) - Item number. This number is assigned to the entry in the listing and referenced in the narrative instructions to identify the material (e.g., "Use cleaning compound, item 5, App E").

b. Column (2) - Level. This column identifies the lowest level of maintenance that requires the listed item

- O - Organizational Maintenance
- F - Direct Support Maintenance
- H - General Support Maintenance

c. Column (3) - National Stock Number. This is the national stock number assigned to the item; use it to request or requisition the item.

d. Column (4) - Description. This column indicates the federal item name and, if required, a description to identify the item. The last line for each item indicates the part number followed by the Federal Supply Code for Manufacturers (FSCM) in parentheses, if applicable.

e. Column (5) - Unit of Measure (U/M). This column indicates the measure used in performing the actual maintenance function. This measure is expressed by a two-character alphabetical abbreviation (e.g., ea, in, pr). If the unit of measure differs from the unit of issue, requisition the lowest unit that will satisfy your requirements.

Section II. EXPENDABLE SUPPLIES AND MATERIALS

(1) Item Number	(2) Level	(3) National Stock Number	(4) Description	(5) U/M
1	0	9135-00-783-8198	Fuel	A/M
2	0	8040-00-738-6429	Cement Epoxy	A/R
3	0	7920-00-205-1711	Rags, Wiping	A/R
4	0	Salvage or locally purchase	Tubing, fuel, 1/16th ID	A/R
5	0	Salvage or locally purchase	Propeller	A/R
6	0	9150-00-273-2389	Oil, Lubricating, General Purpose	A/R
7	0	6810-00-190-1538	Isopropyl Alcohol TT-1-735 (81348)	gal

GLOSSARY

Section I. ABBREVIATIONS

<u>Abbreviation</u>	<u>Description</u>
ANT	antenna
AUX	auxiliary
BAT	battery
CCW	counter clockwise
CH	channel
CHG	charge
CW	clockwise
EIR	equipment improvement recommendation
FSU	flight stabilization unit
GSE	ground support equipment
HI	high
LED	light emitting diode
LO	low
MH	frequency in millions of hertz
PMCS	preventive maintenance checks and services
RCMAT	radio controlled miniature aerial target
R F	radio frequency
RPM	revolutions per minute
RX	receiver
S W	switch
TAMMS	The Army Maintenance Management System
THR	throttle
TX	transmitter
Vac	volts alternating current
Vdc	volts direct current

Section II. DEFINITIONS

<u>Term</u>	<u>Definition</u>
Pitch	Circular movement of aerial target about wing axis.
Roll	Circular movement of aerial target wings about centerline.
Yaw	Circular movement of aerial target fuselage about the vertical axis.

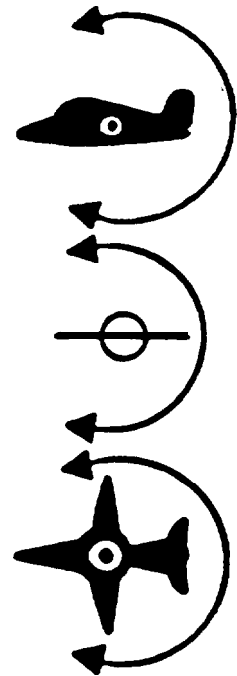

By Order of the Secretary of the Army:

CARL E. VUONO
General, United States Army
Chief of Staff

Official:

THOMAS F. SIKORA
Brigadier General, United States Army
The Adjutant General

DISTRIBUTION:

To be distributed in accordance with DA Form 12-32, Operator, Unit, and Direct Support and General Support Maintenance requirements for the FQM-117 Miniature Aerial Target.

